

 MICROELECTRONICA

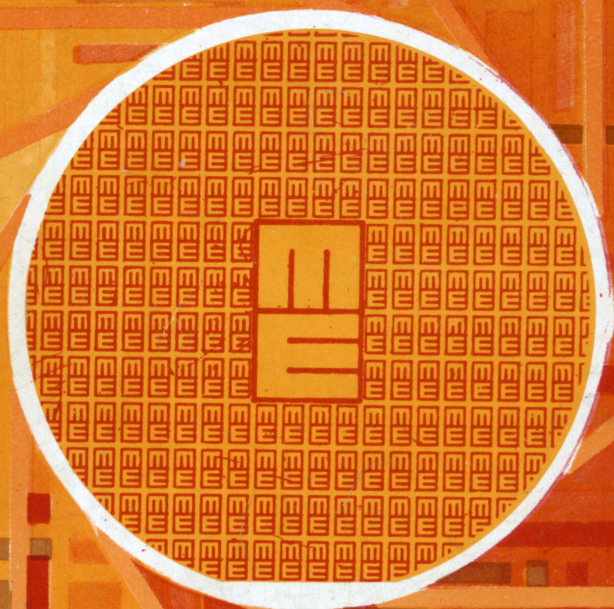

**DATA BOOK**





# **DATA BOOK**

---

## **MOS AND OPTOELECTRONIC DEVICES**

**FIRST EDITION — 1985**

### **INTRODUCTION**

---

This catalog contains data sheets on MICROELECTRONICA range of MOS integrated circuits and OPTOELECTRONIC devices. Additional information can be obtained by contacting Product Marketing Department.

---

---

## TABLE OF CONTENTS

|           |                                    |     |
|-----------|------------------------------------|-----|
| SECTION 1 |                                    |     |
|           | <b>PRODUCT INDEX</b> .....         | 4   |
| SECTION 2 |                                    |     |
|           | <b>CMOS 4000 SERIES</b> .....      | 9   |
| SECTION 3 |                                    |     |
|           | <b>CMOS</b> .....                  | 204 |
| SECTION 4 |                                    |     |
|           | <b>NMOS</b> .....                  | 222 |
| SECTION 5 |                                    |     |
|           | <b>PMOS</b> .....                  | 246 |
| SECTION 6 |                                    |     |
|           | <b>LED S &amp; DISPLAY S</b> ..... | 298 |
| SECTION 7 |                                    |     |
|           | <b>CROSS REFERENCE GUIDE</b> ..... | 332 |



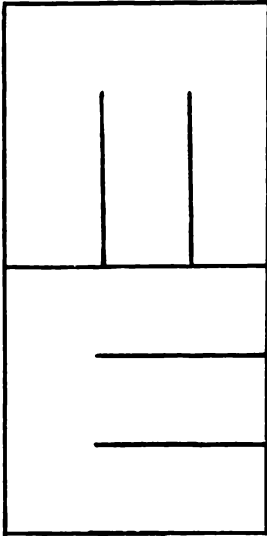

|                              |          |
|------------------------------|----------|
| <b>PRODUCT INDEX</b>         | <b>1</b> |
| <b>CMOS 4000 SERIES</b>      | <b>2</b> |
| <b>CMOS</b>                  | <b>3</b> |
| <b>NMOS</b>                  | <b>4</b> |
| <b>PMOS</b>                  | <b>5</b> |
| <b>LED S &amp; DISPLAY S</b> | <b>6</b> |
| <b>CROSS REFERENCE GUIDE</b> | <b>7</b> |

# PRODUCT INDEX

| TYPE                    | FAMILY | DESCRIPTION   | PAGE |
|-------------------------|--------|---|------|
| <b>CMOS 4000 SERIES</b> |        |   |      |
| MMC 4000●               | CMOS   | Dual 3-input NOR gate plus inverter   | 9    |
| MMC 4001                | CMOS   | Quad 2-input NOR gate   | 9    |
| MMC 4002                | CMOS   | Dual 4-input NOR gate   | 9    |
| MMC 4011                | CMOS   | Quad 2-input NAND gate  | 13   |
| MMC 4012                | CMOS   | Dual 4-input NAND gate  | 13   |
| MMC 4013                | CMOS   | Dual "D" with set/reset capability  | 17   |
| MMC 4014●               | CMOS   | 8-stage with sync parallel or serial input/serial output                            | 21   |
| MMC 4015                | CMOS   | Dual 4-stage with serial input/parallel output                                      | 25   |
| MMC 4016                | CMOS   | Quad bilateral switch   | 28   |
| MMC 4017                | CMOS   | Decade counter/divider plus 10 decoded decimal outputs                              | 32   |
| MMC 4018                | CMOS   | Presetable divide-by "N" counter, fixed or programmable                             | 37   |
| MMC 4019                | CMOS   | Quad AND/OR select  | 41   |
| MMC 4020                | CMOS   | 14-stage binary/ripple counter  | 46   |
| MMC 4021●               | CMOS   | 8-stage with async. parallel input or sync. serial input/serial output              | 21   |
| MMC 4022                | CMOS   | Divide-by-8 counter/divider with 8 decimal outputs                                  | 32   |
| MMC 4023                | CMOS   | Triple 3-input NAND gate  | 13   |
| MMC 4024                | CMOS   | 7-stage binary/ripple counter   | 46   |
| MMC 4025                | CMOS   | Triple 3-input NOR gate   | 9    |
| MMC 4027                | CMOS   | Dual "J-K" master-slave with set/reset capability                                   | 50   |
| MMC 4028                | CMOS   | BCD-to-decimal decoder  | 53   |
| MMC 4029●               | CMOS   | Presetable Up/Down counter, binary or BCD-decade                                    | 56   |
| MMC 4030                | CMOS   | Quad exclusive-OR gate  | 60   |
| MMC 4031                | CMOS   | 64-stage static shift register  | 64   |
| MMC 4035                | CMOS   | 4-stage parallel-in/parallel-out with "J-K" input and true/complement out.          | 68   |
| MMC 4040                | CMOS   | 12-stage binary/ripple counter  | 46   |
| MMC 4041●               | CMOS   | Quad true/complement buffer   | 73   |
| MMC 4042                | CMOS   | Quad clocked "D" latches  | 76   |
| MMC 4043●               | CMOS   | Quad NOR R/S (3-state outputs)  | 80   |
| MMC 4044●               | CMOS   | Quad NAND R/S (3-state outputs)   | 80   |
| MMC 4047                | CMOS   | Monostable/astable multivibrator  | 85   |
| MMC 4048                | CMOS   | Expandable 8-input gate (3-state output)  | 91   |
| MMC 4049                | CMOS   | Hex buffer/converter (inverting)  | 95   |
| MMC 4050                | CMOS   | Hex buffer/converter (non-inverting)  | 95   |
| MMC 4051                | CMOS   | Single 8-channel analog multiplexer-demultiplexer                                   | 98   |
| MMC 4052                | CMOS   | Differential 4-channel analog multiplexer-demultiplexer                             | 98   |
| MMC 4053                | CMOS   | Triple 2-channel analog multiplexer-demultiplexer                                   | 98   |
| MMC 4054●               | CMOS   | 4-segment display driver-strobed latch function                                     | 202  |
| MMC 4055●               | CMOS   | BCD to 7-segment decoder/driver, with "display-frequency" output                    | 202  |
| MMC 4056●               | CMOS   | BCD-to-7 segment decoder/driver with strobed latch function                         | 202  |
| MMC 4060●               | CMOS   | 14-stage ripple-carry binary counter/divider and oscillator                         | 103  |
| MMC 4066                | CMOS   | Quad bilateral switch for transmission or multiplexing of analog or digital signals | 107  |
| MMC 4067                | CMOS   | Single 16-channel analog multiplexer/demultiplexer                                  | 111  |
| MMC 4068●               | CMOS   | 8-input NAND/AND gate   | 116  |
| MMC 4069                | CMOS   | Hex inverter  | 119  |
| MMC 4070                | CMOS   | Quad exclusive OR-gate  | 122  |
| MMC 4071                | CMOS   | Quad 2-input OR gate  | 125  |
| MMC 4072                | CMOS   | Dual 4-input OR gate  | 125  |
| MMC 4073                | CMOS   | Triple 3-input AND gate   | 136  |
| MMC 4075●               | CMOS   | Triple 3-input OR gate  | 125  |
| MMC 4076●               | CMOS   | 4-bit "D" latches with 3-state outputs  | 129  |

| TYPE       | FAMILY | DESCRIPTION   | PAGE |
|------------|--------|---|------|
| MMC 4077   | CMOS   | Quad exclusive NOR gate                                 | 122  |
| MMC 4078●  | CMOS   | 8-input OR/NOR gate                                     | 133  |
| MMC 4081   | CMOS   | Quad 2-input AND gate                                   | 136  |
| MMC 4082●  | CMOS   | Quad 4-input AND gate                                   | 136  |
| MMC 4093   | CMOS   | Quad 2-input NAND Schmitt Triggers                      | 140  |
| MMC 4095●  | CMOS   | Gated "J-K" master-slave (non inverting)                | 144  |
| MMC 4096●  | CMOS   | Gated "J-K" master-slave (inverting and non-inverting)  | 144  |
| MMC 4097   | CMOS   | Differential 8-channel analog multiplexer/demultiplexer | 111  |
| MMC 4098   | CMOS   | Dual monostable multivibrator                           | 149  |
| MMC 4503   | CMOS   | Hex Buffer (3-state non-inverting)                      | 154  |
| MMC 4508●  | CMOS   | Dual 4-bit latch (3-state outputs)                      | 157  |
| MMC 4510●  | CMOS   | Presettable 4-bit BCD up/down counter                   | 162  |
| MMC 4511   | CMOS   | BCD-to-seven segment latch/decoder/driver               | 168  |
| MMC 4516   | CMOS   | Presettable 4-bit binary up/down counter                | 162  |
| MMC 4518   | CMOS   | Dual BCD up counter                                     | 174  |
| MMC 4520●  | CMOS   | Dual binary up counter                                  | 174  |
| MMC 4543   | CMOS   | BCD-to-seven segment latch/decoder/driver               | 179  |
| MMC 40104  | CMOS   | 4-bit bidirectional universal shift register            | 184  |
| MMC 40107  | CMOS   | Dual 2-input NAND buffer/driver                         | 188  |
| MMC 40181  | CMOS   | 4-bit arithmetic logic unit                             | 192  |
| MMC 40192  | CMOS   | Presettable 4-bit BCD up/down counter                   | 197  |
| MMC 40193● | CMOS   | Presettable 4-bit binary up/down counter                | 197  |

**SPECIAL CMOS**

|          |      |                                     |     |
|----------|------|-------------------------------------|-----|
| MMC 300  | CMOS | Motor drive clock circuit           | 204 |
| MMC 351  | CMOS | Auto clock                          | 207 |
| MMC 760  | CMOS | Loop disconnect dialler             | 209 |
| MMC 761● | CMOS | Dual tone multi-frequency generator | 216 |
| MMC 9500 | CMOS | Clock generator                     | 219 |

**NMOS**

|          |      |                       |     |
|----------|------|-----------------------|-----|
| MMN 2102 | NMOS | 1024-bit static RAM   | 222 |
| MMN 2114 | NMOS | 1024x4-bit static RAM | 225 |
| MMN 4027 | NMOS | 4096-bit dynamic RAM  | 229 |
| MMN 4116 | NMOS | 16384-bit dynamic RAM | 237 |

**PMOS**

|          |      |  |     |
|----------|------|--|-----|
| MMP 01*  | PMOS | Multifunctional gate   |     |
| MMP 02*  | PMOS | Dual 16-bit static shift register  | 246 |
| MMP 03*  | PMOS | 64-bit dynamic shift register  | 248 |
| MMP 06*  | PMOS | Quad p-channel enhancement MOSFET  |     |
| MMP 102  | PMOS | Dual 3-input NOR gate  | 250 |
| MMP 106  | PMOS | Quad 2-input NOR gate  | 252 |
| MMP 107  | PMOS | Quad 2-input AND(NAND) gate  | 254 |
| MMP 115  | PMOS | 6-channel analog switch  | 256 |
| MMP 116  | PMOS | 5-channel analog switch  | 258 |
| MMP 117  | PMOS | 5-channel analog switches  | 260 |
| MMP 119  | PMOS | 3x2-channel analog switches  | 262 |
| MMP 122  | PMOS | 2x2-channel analog switch  | 264 |
| MMP 124  | PMOS | 4-channel analog switch  | 266 |
| MMP 131  | PMOS | 1000:1 static frequency divider  | 268 |
| MMP 156* | PMOS | 256-bit dynamic shift register   | 270 |
| MMP 160* | PMOS | Dual 80-bit static shift register  |     |
| MMP 190  | PMOS | Digital multimeter logic   | 272 |
| MMP 311  | PMOS | 5-stage static shift register synchronous parallel or serial input/parallel output | 279 |
| MMP 708  | PMOS | Programmable controller for thyristors triacs or transistors                       |     |

| TYPE     | FAMILY | DESCRIPTION  | PAGE |
|----------|--------|--|------|
| MMP 710  | PMOS   | 8-channel touch control circuit for TV program selection | 281  |
| MMP 711  | PMOS   | 1 of 8 binary decoder                                    | 284  |
| MMP 5002 | PMOS   | 4-digit counter/display decoder                          | 287  |
| MMP 5005 | PMOS   | 4-digit counter/display decoder                          | 287  |
| MMP 5007 | PMOS   | 4-digit counter/display decoder                          | 287  |
| MMP 5009 | PMOS   | Counter time-base circuit                                | 292  |

## LED & DISPLAY

|           |     |                                   |     |
|-----------|-----|-----------------------------------|-----|
| MDE 1101R | LED | Standard light emitting diodes    | 298 |
| 2R        | LED |                                   |     |
| 3R        | LED |                                   |     |
| MDE 1101P | LED |                                   |     |
| 2P        | LED |                                   |     |
| 3P        | LED |                                   |     |
| MDE 1101G | LED |                                   |     |
| 2G        | LED |                                   |     |
| 3G        | LED |                                   |     |
| MDE 1101V | LED |                                   |     |
| 2V        | LED |                                   |     |
| 3V        | LED |                                   |     |
| MDE 1531R | LED | Rectangular light emitting diodes | 301 |
| 2R        | LED |                                   |     |
| 3R        | LED |                                   |     |
| MDE 1531P | LED |                                   |     |
| 2P        | LED |                                   |     |
| 3P        | LED |                                   |     |
| MDE 1531G | LED |                                   |     |
| 2G        | LED |                                   |     |
| 3G        | LED |                                   |     |
| MDE 1531V | LED |                                   |     |
| 2V        | LED |                                   |     |
| 3V        | LED |                                   |     |
| MDE 1541R | LED | Triangular light emitting diodes  | 304 |
| 2R        | LED |                                   |     |
| 3R        | LED |                                   |     |
| MDE 1541P | LED |                                   |     |
| 2P        | LED |                                   |     |
| 3P        | LED |                                   |     |
| MDE 1541G | LED |                                   |     |
| 2G        | LED |                                   |     |
| 3G        | LED |                                   |     |
| MDE 1541V | LED |                                   |     |
| 2V        | LED |                                   |     |
| 3V        | LED |                                   |     |
| MDE 1601R | LED | Resistor LED's                    | 307 |
| 2R        | LED |                                   |     |
| 3R        | LED |                                   |     |
| MDE 1601P | LED |                                   |     |
| 2P        | LED |                                   |     |
| 3P        | LED |                                   |     |
| MDE 1601G | LED |                                   |     |
| 2G        | LED |                                   |     |
| 3G        | LED |                                   |     |
| MDE 1601V | LED |                                   |     |
| 2V        | LED |                                   |     |
| 3V        | LED |                                   |     |



| TYPE       | FAMILY  | DESCRIPTION   | PAGE |
|------------|---------|---|------|
| MDE 2101R  | DISPLAY | 0.3 inch red seven segment display right hand or left hand decimal point common anode     | 310  |
| 2R         | DISPLAY |   |      |
| 3R         | DISPLAY |   |      |
| 4R         | DISPLAY |   |      |
| MDE 2101V  | DISPLAY | 0.3 inch green seven segment display right hand or left hand decimal point common anode   |      |
| 2V         | DISPLAY |   |      |
| 3V         | DISPLAY |   |      |
| 4V         | DISPLAY |   |      |
| MDE 2111R  | DISPLAY | 0.3 inch red seven segment display right hand or left hand decimal point common cathode   | 314  |
| 2R         | DISPLAY |   |      |
| 3R         | DISPLAY |   |      |
| 4R         | DISPLAY |   |      |
| MDE 2111V  | DISPLAY | 0.3 inch green seven segment display right hand or left hand decimal point common cathode | 314  |
| 2V         | DISPLAY |   |      |
| 3V         | DISPLAY |   |      |
| 4V         | DISPLAY |   |      |
| MDE 2201R  | DISPLAY | 0.3 inch red overflow indicator right hand or left hand decimal point common anode        | 318  |
| 2R         | DISPLAY |   |      |
| 3R         | DISPLAY |   |      |
| 4R         | DISPLAY |   |      |
| MDE 2201V  | DISPLAY | 0.3 inch green overflow indicator right hand or left hand decimal point common anode      | 318  |
| 2V         | DISPLAY |   |      |
| 3V         | DISPLAY |   |      |
| 4V         | DISPLAY |   |      |
| MDE 2211R  | DISPLAY | 0.3 inch red overflow indicator right hand or left hand decimal point common cathode      | 322  |
| 2R         | DISPLAY |   |      |
| 3R         | DISPLAY |   |      |
| 4R         | DISPLAY |   |      |
| MDE 2211V  | DISPLAY | 0.3 inch green overflow indicator right hand or left hand decimal point common cathode    | 322  |
| 2V         | DISPLAY |   |      |
| 3V         | DISPLAY |   |      |
| 4V         | DISPLAY |   |      |
| MDE 2573R  | DISPLAY | 0.3 inch 4 digits red LED numeric display   |      |
| 4R         | DISPLAY |   |      |
| MDE 2573V  | DISPLAY | 0.3 inch 4 digits green LED numeric display   | 326  |
| 4V         | DISPLAY |   |      |
| MDE 2583 R | DISPLAY | 0.3 inch 4 digits red LED numeric display   | 328  |
| 4 R        | DISPLAY |   |      |
| MDE 2583 V | DISPLAY | 0.3 inch 4 digits green LED numeric display   |      |
| 4V         | DISPLAY |   |      |
| MDE 2911 R | LED     | Light indicator with discret LED s (bar graph display)                                    | 330  |
| 2R         | LED     |   |      |
| MDE 2911P  | LED     |   |      |
| 2P         | LED     |   |      |
| MDE 2911G  | LED     |   |      |
| 2G         | LED     |   |      |
| MDE 2911V  | LED     |   |      |
| 2V         | LED     |   |      |

\* Not recommended for new design

• Product in development

---

## GENERAL OPERATING AND HANDLING CONSIDERATIONS

### Power - Source Rules

1. The power — supply polarity for CMOS circuits should not be reversed. The positive ( $V_{DD}$ ) terminal should never be more than 0.5V negative with respect to the negative ( $V_{SS}$ ) terminal ( $V_{DD} - V_{SS} > -0.5V$ ). Reversal of polarities will forward — bias and short the structured and protection diode between  $V_{DD}$  and  $V_{SS}$ .
2. Power — source current capability should be limited to the minimum value which will assure good logic operation.
3. Large values of resistors in series with  $V_{DD}$  or  $V_{SS}$  should be avoided transient turn-on of input protection diodes can result from drops across such resistors during switching.
4. When separate power — supplies are used for the CMOS device and for the device inputs, the device power supply should always be turned on before the independent input signal sources, and the input signals should be turned off before the powersupply is turned off ( $V_{SS} < V_i < V_{DD}$  as a maximum limit). This rule will prevent ever dissipation and possible damage to the input protection diode when the device power supply is grounded. When the device power supply is an open circuit, violation of this rule can result in the undesired circuit operation although device damage should not result; ac inputs can be rectified by input diode to act as a power supply

### Input signal rules

1. All CMOS inputs should be terminated. When CMOS inputs are wired to edge card connectors with CMOS drive coming from another DC board, a shunt resistor should be connected to  $V_{DD}$  or  $V_{SS}$ .
2. When CMOS circuits are driven by TTL logic a pull-up resistors should be connected from the CMOS inputs to 5V.
3. Input rise and fall times for clocked devices must not exceed 15  $\mu s$  in order to avoid high consumption, false triggering etc. With slower inputs a Schmitt trigger must be employed.

### Gate - Oxide Protection Network

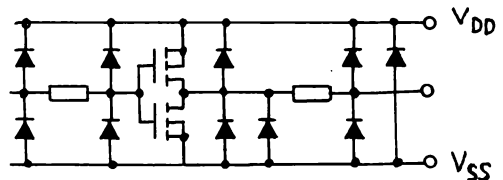
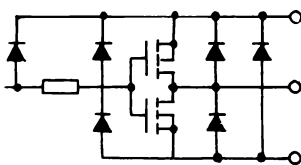

## ORDERING NUMBERS CMOS 4000 SERIES

- MMC 4XXX E — for dual in-line plastic package, intermediate temperature range
- MMC 4XXX F — for dual in-line ceramic package, frit seal, intermediate temperature range
- MMC 4XXX G — for dual in-line ceramic package, extended temperature range
- MMC 4XXX H — for dual in-line ceramic package, frit seal, extended temperature range

# NOR GATES: 4000 DUAL 3 INPUT PLUS INVERTER

# 4001 QUAD 2 INPUT

# 4002 DUAL 4 INPUT

# 4025 TRIPLE 3 INPUT

## GENERAL DESCRIPTION

These NOR gates are monolithic complementary MOS (CMOS) integrated circuits. The N and P channel enhancement mode transistors provide a symmetrical circuit with output swings essentially equal to the supply voltage. This results in high noise immunity over a wide supply voltage range. No DC power other than that caused by leakage current is consumed during static conditions. All inputs are protected against static discharge and latching conditions.

The MMC 4000, MMC 4001, MMC 4002 and MMC 4025E/F/G/H

NOR gates provide the system designer with direct implementation of the NOR function.

The MMC 4000, MMC 4001, MMC 4002 and MMC 4025E/F/G/H types are supplied in 14-lead hermetic dual-in-line ceramic or plastic packages

## FEATURES

- Propagation delay time = 60 ns (typ) at  $C_L = 50$  pF  $V_{DD} = 10$  V
- Buffered inputs and outputs
- Standardized symmetrical output characteristics
- 100% tested for maximum quiescent current
- 5 V, 10 V and 15 V parametric ratings
- High noise immunity: 0.45  $V_{DD}$  (typical)

2

## ABSOLUTE MAXIMUM RATINGS

|            |  |  |                          |             |
|------------|--|--|--------------------------|-------------|
| $V_{DD}^*$ | Supply voltage: G and H types<br>E and F types   | -0.5 to 20<br>-0.5 to 18<br>-0.5 to 18 | 20<br>18<br>$V_{DD}+0.5$ | V<br>V<br>V |
| $V_i$      | Input voltage  |  |                          | V           |
| $I_i$      | DC input current (any one input)   |  | $\pm 10$                 | mA          |
| $P_{tot}$  | Total power dissipation (per package)<br>Dissipation per output transistor<br>for $T_A =$ full package-temperature range |  | 200                      | mW          |
| $T_A$      | Operating temperature :  |  | 100                      | mW          |
|            | G and H types  | -55 to 125                             |                          | °C          |
|            | E and F types  | -40 to 85                              |                          | °C          |
| $T_{stg}$  | Storage temperature  | -65 to 150                             |                          | °C          |

\* All voltage values are referred to  $V_{SS}$  pin voltage

## RECOMMENDED OPERATING CONDITIONS

|            |  |                    |          |        |
|------------|--|--------------------|----------|--------|
| $V_{DD}^*$ | Supply voltage: G and H types<br>E and F types | 3 to 18<br>3 to 15 | 18<br>15 | V<br>V |
| $V_i$      | Input voltage                                  | 0 to               | $V_{DD}$ | V      |
| $T_A$      | Operating temperature :                        |                    |          |        |
|            | G and H types                                  | -55 to 125         |          | °C     |
|            | E and F types                                  | -40 to 85          |          | °C     |

## CONNECTION DIAGRAMS

**MMC 4000**

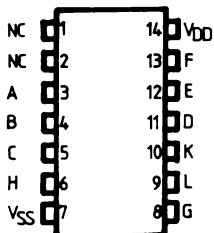

**MMC 4001**

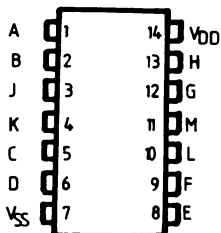

**MMC 4002**

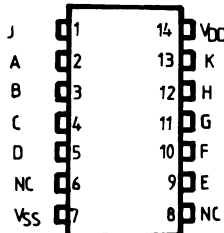

**MMC 4025**

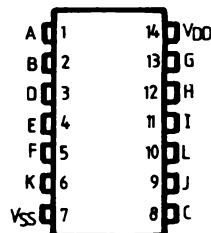

**STATIC ELECTRICAL CHARACTERISTICS**

(over recommended operating conditions)

| PARAMETER   |            | TEST CONDITIONS       |                            |                                |                        | VALUES                |                      |                       |                        |                      |                       | UNIT                 |         |
|---|------------|-----------------------|----------------------------|--------------------------------|------------------------|-----------------------|----------------------|-----------------------|------------------------|----------------------|-----------------------|----------------------|---------|
|   |            | V <sub>I</sub><br>(V) | V <sub>O</sub><br>(V)      | I <sub>O</sub>  <br>( $\mu$ A) | V <sub>DD</sub><br>(V) | T <sub>LOW</sub> *    |                      | 25°C                  |                        |                      | T <sub>HIGH</sub> *   |                      |         |
|   |            |                       |                            |                                |                        | min.                  | max.                 | min.                  | typ                    | max.                 | min.                  |                      | max.    |
| I <sub>L</sub> Quiescent current                        | G, H types | 0/ 5                  |                            |                                | 5                      |                       | 0.25                 |                       | 0.01                   | 0.25                 |                       | 7.5                  | $\mu$ A |
|   |            | 0/10                  |                            |                                | 10                     |                       | 0.5                  |                       | 0.01                   | 0.5                  |                       | 15                   |         |
|   |            | 0/15                  |                            |                                | 15                     |                       | 1                    |                       | 0.01                   | 1                    |                       | 30                   |         |
|   |            | 0/20                  |                            |                                | 20                     |                       | 5                    |                       | 0.02                   | 5                    |                       | 150                  |         |
|   | E, F types | 0/ 5                  |                            |                                | 5                      |                       | 1                    |                       | 0.01                   | 1                    |                       | 7.5                  |         |
|   |            | 0/10                  |                            |                                | 10                     |                       | 2                    |                       | 0.01                   | 2                    |                       | 15                   |         |
|   | 0/15       |                       |                            | 15                             |                        | 4                     |                      | 0.01                  | 4                      |                      | 30                    |                      |         |
| V <sub>OH</sub> Output high voltage                     |            | 0/ 5<br>0/10<br>0/15  |                            | < 1<br>< 1<br>< 1              | 5<br>10<br>15          | 4.95<br>9.95<br>14.95 |                      | 4.95<br>9.95<br>14.95 |                        |                      | 4.95<br>9.95<br>14.95 |                      | V       |
| V <sub>OL</sub> Output low voltage                      |            | 5 /0<br>10/0<br>15/0  |                            | < 1<br>< 1<br>< 1              | 5<br>10<br>15          |                       | 0.05<br>0.05<br>0.05 |                       |                        | 0.05<br>0.05<br>0.05 |                       | 0.05<br>0.05<br>0.05 | V       |
| V <sub>IH</sub> Input high voltage                      |            |                       | 0.5/4.5<br>1/9<br>1.5/13.5 | < 1<br>< 1<br>< 1              | 5<br>10<br>15          | 3.5<br>7<br>11        |                      | 3.5<br>7<br>11        |                        |                      | 3.5<br>7<br>11        |                      | V       |
| V <sub>IL</sub> Input low voltage                       |            |                       | 4.5/0.5<br>9/1<br>13.5/1.5 | < 1<br>< 1<br>< 1              | 5<br>10<br>15          |                       | 1.5<br>3<br>4        |                       |                        | 1.5<br>3<br>4        |                       | 1.5<br>3<br>4        | V       |
| I <sub>OH</sub> Output drive current                    | G, H types | 0/ 5                  | 2.5                        |                                | 5                      | -2                    |                      | -1.6                  | -3.2                   |                      | -1.15                 |                      | mA      |
|   |            | 0/ 5                  | 4.6                        |                                | 5                      | -0.64                 |                      | -0.51                 | -1                     |                      | -0.36                 |                      |         |
|   |            | 0/10                  | 9.5                        |                                | 10                     | -1.6                  |                      | -1.3                  | -2.6                   |                      | -0.9                  |                      |         |
|   |            | 0/15                  | 13.5                       |                                | 15                     | -4.2                  |                      | -3.4                  | -6.8                   |                      | -2.4                  |                      |         |
|   | E, F types | 0/ 5                  | 2.5                        |                                | 5                      | -1.53                 |                      | -1.36                 | -3.2                   |                      | -1.1                  |                      |         |
|   |            | 0/ 5                  | 4.6                        |                                | 5                      | -0.52                 |                      | -0.44                 | -1                     |                      | -0.36                 |                      |         |
|   | 0/10       | 9.5                   |                            | 10                             | -1.3                   |                       | -1.1                 | -2.6                  |                        | -0.9                 |                       |                      |         |
|   | 0/15       | 13.5                  |                            | 15                             | -3.6                   |                       | -3.0                 | -6.8                  |                        | -2.4                 |                       |                      |         |
| I <sub>OL</sub> Output sink current                     | G, H types | 0/ 5                  | 0.4                        |                                | 5                      | 0.64                  |                      | 0.51                  | 1                      |                      | 0.36                  |                      | mA      |
|   |            | 0/10                  | 0.5                        |                                | 10                     | 1.6                   |                      | 1.3                   | 2.6                    |                      | 0.9                   |                      |         |
|   |            | 0/15                  | 1.5                        |                                | 15                     | 4.2                   |                      | 3.4                   | 6.8                    |                      | 2.4                   |                      |         |
|   | E, F types | 0/ 5                  | 0.4                        |                                | 5                      | 0.52                  |                      | 0.44                  | 1                      |                      | 0.36                  |                      |         |
|   |            | 0/10                  | 0.5                        |                                | 10                     | 1.3                   |                      | 1.1                   | 2.6                    |                      | 0.9                   |                      |         |
|   |            | 0/15                  | 1.5                        |                                | 15                     | 3.6                   |                      | 3.0                   | 6.8                    |                      | 2.4                   |                      |         |
| I <sub>IH</sub> , I <sub>IL</sub> Input leakage current | G, H types | 0/18                  | Any input                  |                                | 18                     |                       | $\pm$ 0.1            |                       | $\pm$ 10 <sup>-5</sup> | $\pm$ 0.1            |                       | $\pm$ 1              | $\mu$ A |
|   | E, F types | 0/15                  |                            |                                | 15                     |                       | $\pm$ 0.3            |                       | $\pm$ 10 <sup>-5</sup> | $\pm$ 0.3            |                       | $\pm$ 1              |         |
| C <sub>I</sub> Input capacitance                        |            |                       | Any input                  |                                |                        |                       |                      |                       | 5                      | 7.5                  |                       |                      | pF      |

\* T<sub>LOW</sub> = -55°C for G, H devices; -40°C for E, F devices.

\* T<sub>HIGH</sub> = +125°C for G, H devices; +85°C for E, F devices.

The Noise Margin for both "1" and "0" level is:

- 1 V min. with V<sub>DD</sub> = 5 V
- 2 V min. with V<sub>DD</sub> = 10 V
- 2.5 V min. with V<sub>DD</sub> = 15 V

**DYNAMIC ELECTRICAL CHARACTERISTICS**

( $T_A = 25^\circ\text{C}$ ,  $C_L = 50\text{ pF}$ ,  $R_L = 200\text{ k}$ , typical temperature coefficient for all  $V_{DD}$  values is  $0.3\%/^\circ\text{C}$ , all input rise and fall times =  $20\text{ ns}$ )

| PARAMETER                        | TEST CONDITIONS | VALUES       |     |     | UNIT |
|----------------------------------|-----------------|--------------|-----|-----|------|
|                                  |                 | $V_{DD}$ (V) | min | typ |      |
| $t_{PLH}$ Propagation delay time | 5               |              | 125 | 250 | ns   |
|                                  | 10              |              | 60  | 120 |      |
|                                  | 15              |              | 45  | 90  |      |
| $t_{THL}$ Transition time        | 5               |              | 100 | 200 | ns   |
|                                  | 10              |              | 50  | 100 |      |
|                                  | 15              |              | 40  | 80  |      |

**SCHEMATIC AND LOGIC DIAGRAMS**

**MMC 4000**

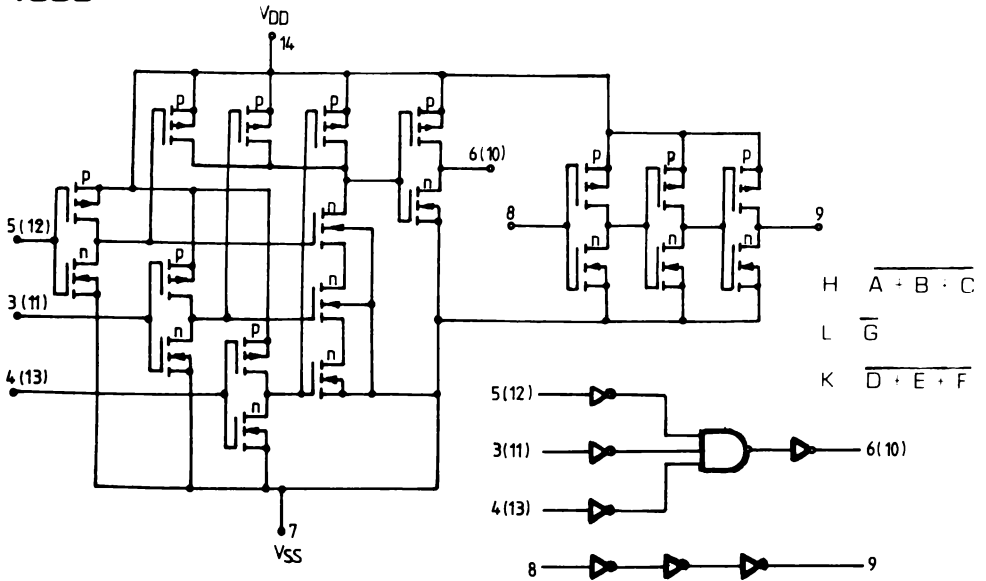

**MMC 4001**

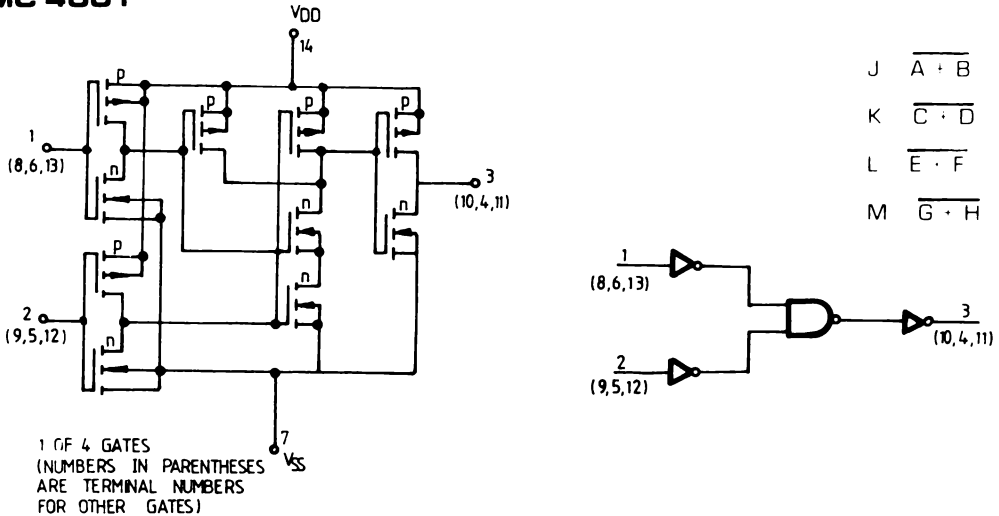

MMC 4002

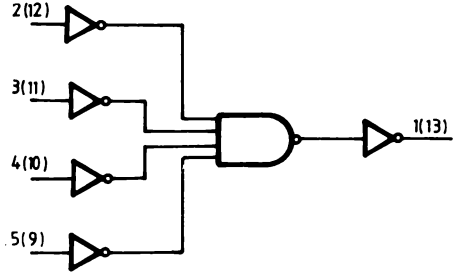
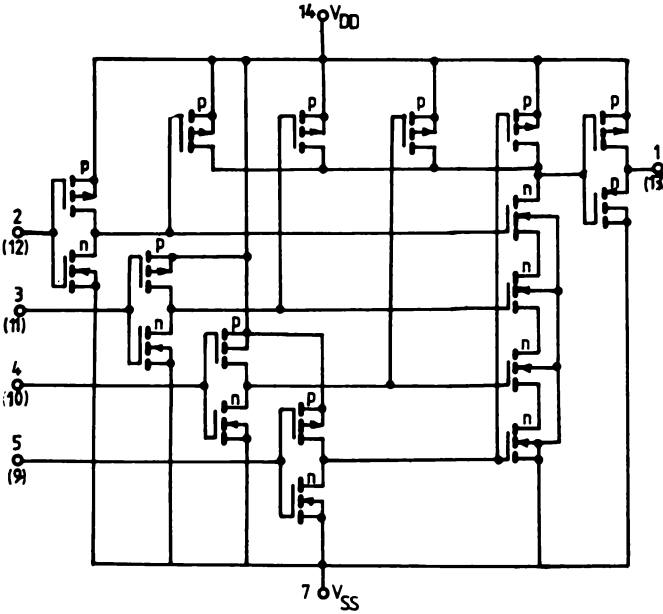

$$J = \overline{A + B + C + D}$$

$$K = \overline{E + F + G + H}$$

MMC 4025

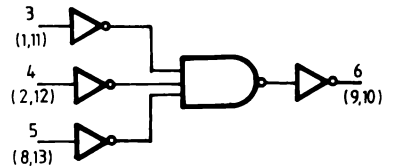
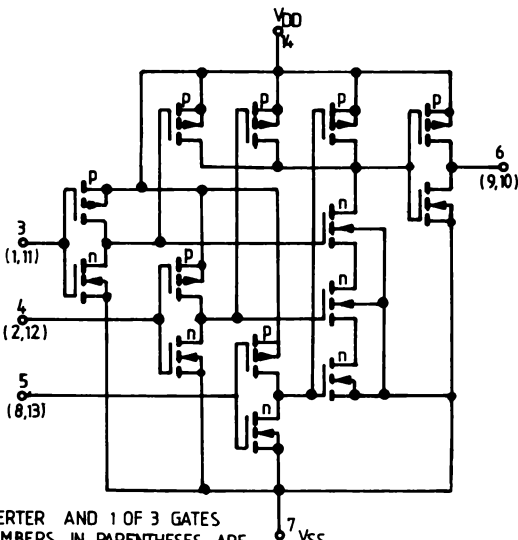

$$J = \overline{A + B + C}$$

$$K = \overline{D + E + F}$$

$$L = \overline{G + H + I}$$

INVERTER AND 1 OF 3 GATES  
(NUMBERS IN PARENTHESES ARE  
TERMINAL NUMBERS FOR SECOND GATE)

# NAND GATES: 4011 QUAD 2 INPUT 4012 DUAL 4 INPUT 4023 TRIPLE 3 INPUT

## GENERAL DESCRIPTION

These NAND gates are monolithic complementary MOS (CMOS) integrated circuits. The N and P channel enhancement mode transistors provide a symmetrical circuit with output swings essentially equal to the supply voltage. This results in high noise immunity over a wide supply voltage range. No. DC power other than that caused by leakage current is consumed during static conditions. All inputs are protected against static discharge and latching conditions.

The MMC 4011, MMC 4012 and MMC 4023E/F/G/H NAND gates provide the system designer with direct implementation of the NAND function. All inputs and outputs are buffered.

The MMC 4011, MMC 4012 and MMC 4023E/F/G/H types are supplied in 14-lead hermetic dual-in-line ceramic or plastic packages.

## FEATURES

- Propagation delay time = 60 ns (typ.) at  $C_L = 50$  pF,  $V_{DD} = 10$  V
- Buffered inputs and outputs
- 5 V, 10 V and 15 V parametric ratings
- 100% tested quiescent current
- High noise immunity  $0.45 V_{DD}$  (typical)

## APPLICATIONS

- Automotive
- Data terminals
- Instrumentation
- Medical electronics
- Alarm system
- Industrial controls
- Remote metering
- Computers

## ABSOLUTE MAXIMUM RATINGS

|            |   |         |                |             |
|------------|---|---------|----------------|-------------|
| $V_{DD}^*$ | Supply voltage: G and H types<br>E and F types  | -0.5 to | 20             | V           |
| $V_i$      | Input voltage   | -0.5 to | $V_{DD} + 0.5$ | V           |
| $I_i$      | DC input current (any one input)  |         | $\pm 10$       | mA          |
| $P_{tot}$  | Total power dissipation (per package)<br>Dissipation per output transistor<br>for $T_{op} =$ full package-temperature range |         | 200            | mW          |
| $T_A$      | Operating temperature: G and H types<br>E and F types   | -55 to  | 125            | $^{\circ}C$ |
| $T_{stg}$  | Storage temperature   | -40 to  | 85             | $^{\circ}C$ |
|            |   | -65 to  | 150            | $^{\circ}C$ |

\* All voltages are referred to  $V_{SS}$  pin voltage

## RECOMMENDED OPERATING CONDITIONS

|            |   |        |          |             |
|------------|---|--------|----------|-------------|
| $V_{DD}^*$ | Supply voltage: G and H types<br>E and F types        | 3 to   | 18       | V           |
| $V_i$      | Input voltage   | 3 to   | 15       | V           |
| $T_A$      | Operating temperature: G and H types<br>E and F types | 0 to   | $V_{DD}$ | V           |
|            |   | -55 to | 125      | $^{\circ}C$ |
|            |   | -40 to | 85       | $^{\circ}C$ |

## CONNECTION DIAGRAMS

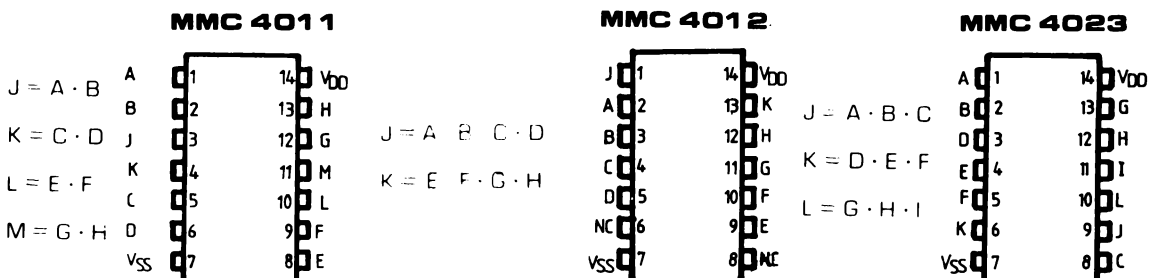

**SCHEMATIC AND LOGIC DIAGRAMS**

**MMC 4011**

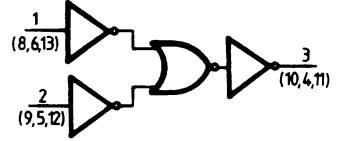
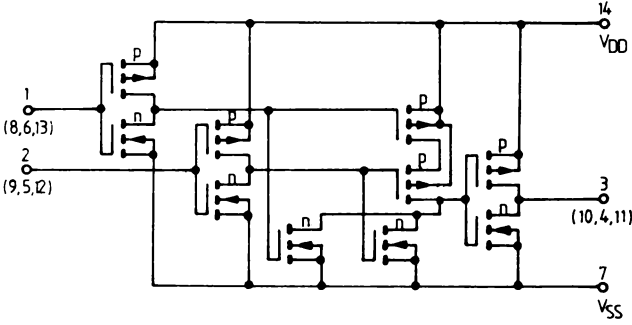

**MMC 4012**

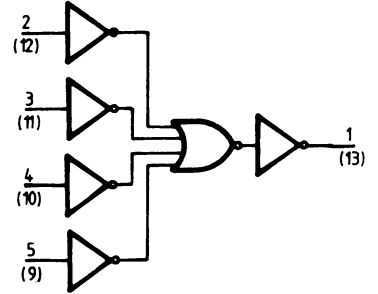
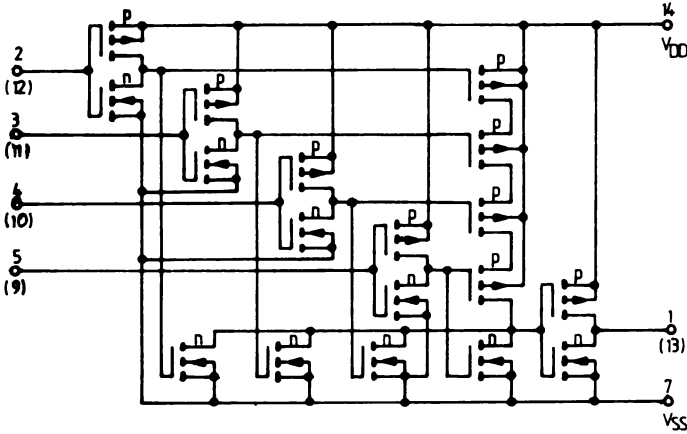

**MMC 4023**

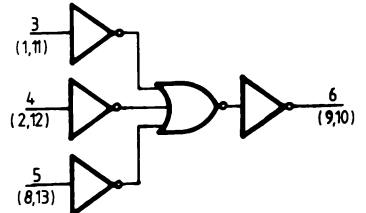
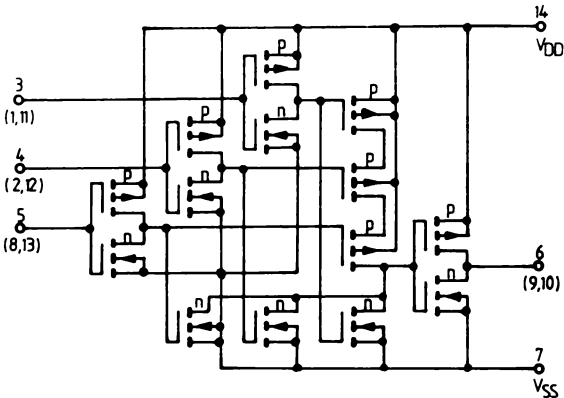



**STATIC ELECTRICAL CHARACTERISTICS**

(over recommended operating conditions)

| PARAMETER   |            | TEST CONDITIONS       |                            |                                |                        | VALUES                |                      |                       |               |                      |                       | UNIT    |         |
|---|------------|-----------------------|----------------------------|--------------------------------|------------------------|-----------------------|----------------------|-----------------------|---------------|----------------------|-----------------------|---------|---------|
|   |            | V <sub>I</sub><br>(V) | V <sub>O</sub><br>(V)      | I <sub>O</sub>  <br>( $\mu$ A) | V <sub>DD</sub><br>(V) | T <sub>LOW</sub> *    |                      | 25°C                  |               |                      | T <sub>HIGH</sub> *   |         |         |
|   |            |                       |                            |                                |                        | min.                  | max.                 | min.                  | typ           | max.                 | min.                  |         | max.    |
| I <sub>L</sub> Quiescent current                      | G, H types | 0/ 5                  |                            |                                | 5                      |                       | 0.25                 |                       | 0.01          | 0.25                 |                       | 7.5     | $\mu$ A |
|   |            | 0/10                  |                            |                                | 10                     |                       | 0.5                  |                       | 0.01          | 0.5                  |                       | 15      |         |
|   |            | 0/15                  |                            |                                | 15                     |                       | 1                    |                       | 0.01          | 1                    |                       | 30      |         |
|   |            | 0/20                  |                            |                                | 20                     |                       | 5                    |                       | 0.02          | 5                    |                       | 150     |         |
|   | E, F types | 0/ 5                  |                            |                                | 5                      |                       | 1                    |                       | 0.01          | 1                    |                       | 7.5     |         |
|   |            | 0/10                  |                            |                                | 10                     |                       | 2                    |                       | 0.01          | 2                    |                       | 15      |         |
|   | 0/15       |                       |                            | 15                             |                        | 4                     |                      | 0.01                  | 4             |                      | 30                    |         |         |
| V <sub>OH</sub> Output high voltage                   |            | 0/ 5<br>0/10<br>0/15  |                            | < 1<br>< 1<br>< 1              | 5<br>10<br>15          | 4.95<br>9.95<br>14.95 |                      | 4.95<br>9.95<br>14.95 |               |                      | 4.95<br>9.95<br>14.95 |         | V       |
| V <sub>OL</sub> Output low voltage                    |            | 5 /0<br>10/0<br>15/0  |                            | < 1<br>< 1<br>< 1              | 5<br>10<br>15          |                       | 0.05<br>0.05<br>0.05 |                       |               | 0.05<br>0.05<br>0.05 | 0.05<br>0.05<br>0.05  |         | V       |
| V <sub>IH</sub> Input high voltage                    |            |                       | 0.5/4.5<br>1/9<br>1.5/13.5 | < 1<br>< 1<br>< 1              | 5<br>10<br>15          | 3.5<br>7<br>11        |                      | 3.5<br>7<br>11        |               |                      | 3.5<br>7<br>11        |         | V       |
| V <sub>IL</sub> Input low voltage                     |            |                       | 4.5/0.5<br>9/1<br>13.5/1.5 | < 1<br>< 1<br>< 1              | 5<br>10<br>15          |                       | 1.5<br>3<br>4        |                       |               | 1.5<br>3<br>4        | 1.5<br>3<br>4         |         | V       |
| I <sub>OH</sub> Output drive current                  | G, H types | 0/ 5                  | 2.5                        |                                | 5                      | -2                    |                      | -1.6                  | -3.2          |                      | -1.15                 |         | mA      |
|   |            | 0/ 5                  | 4.6                        |                                | 5                      | -0.64                 |                      | -0.51                 | -1            |                      | -0.36                 |         |         |
|   |            | 0/10                  | 9.5                        |                                | 10                     | -1.6                  |                      | -1.3                  | -2.6          |                      | -0.9                  |         |         |
|   |            | 0/15                  | 13.5                       |                                | 15                     | -4.2                  |                      | -3.4                  | -6.8          |                      | -2.4                  |         |         |
|   | E, F types | 0/ 5                  | 2.5                        |                                | 5                      | -1.53                 |                      | -1.36                 | -3.2          |                      | -1.1                  |         |         |
|   |            | 0/ 5                  | 4.6                        |                                | 5                      | -0.52                 |                      | -0.44                 | -1            |                      | -0.36                 |         |         |
|   | 0/10       | 9.5                   |                            | 10                             | -1.3                   |                       | -1.1                 | -2.6                  |               | -0.9                 |                       |         |         |
|   | 0/15       | 13.5                  |                            | 15                             | -3.6                   |                       | -3.0                 | -6.8                  |               | -2.4                 |                       |         |         |
| I <sub>OL</sub> Output sink current                   | G, H types | 0/ 5                  | 0.4                        |                                | 5                      | 0.64                  |                      | 0.51                  | 1             |                      | 0.36                  |         | mA      |
|   |            | 0/10                  | 0.5                        |                                | 10                     | 1.6                   |                      | 1.3                   | 2.6           |                      | 0.9                   |         |         |
|   |            | 0/15                  | 1.5                        |                                | 15                     | 4.2                   |                      | 3.4                   | 6.8           |                      | 2.4                   |         |         |
|   | E, F types | 0/ 5                  | 0.4                        |                                | 5                      | 0.52                  |                      | 0.44                  | 1             |                      | 0.36                  |         |         |
|   |            | 0/10                  | 0.5                        |                                | 10                     | 1.3                   |                      | 1.1                   | 2.6           |                      | 0.9                   |         |         |
|   |            | 0/15                  | 1.5                        |                                | 15                     | 3.6                   |                      | 3.0                   | 6.8           |                      | 2.4                   |         |         |
| I <sub>IH</sub> I <sub>IL</sub> Input leakage current | G, H types | 0/18                  | Any input                  |                                | 18                     |                       | $\pm 0.1$            |                       | $\pm 10^{-5}$ | $\pm 0.1$            |                       | $\pm 1$ | $\mu$ A |
|   | E, F types | 0/15                  |                            |                                | 15                     |                       | $\pm 0.3$            |                       | $\pm 10^{-5}$ | $\pm 0.3$            |                       | $\pm 1$ |         |
| C <sub>I</sub> Input capacitance                      |            |                       | Any input                  |                                |                        |                       |                      |                       | 5             | 7.5                  |                       |         | pF      |

\* T<sub>LOW</sub> = -55°C for G, H devices; -40°C for E, F devices.

\* T<sub>HIGH</sub> = +125°C for G, H devices; +85°C for E, F devices.

The Noise Margin for both "1" and "0" level is:

1 V min. with V<sub>DD</sub> = 5 V

2 V min. with V<sub>DD</sub> = 10 V

2.5 V min. with V<sub>DD</sub> = 15 V

**DYNAMIC ELECTRICAL CHARACTERISTICS**

( $T_A = 25^\circ\text{C}$ ,  $C_L = 50\text{ pF}$ ,  $R_L = 200\text{ k}$ , typical temperature coefficient for all  $V_{DD}$  values is  $0.3\%/^\circ\text{C}$ , all input rise and fall times = 20 ns)

| PARAMETER                                       | TEST CONDITIONS | VALUES |     |     | UNIT |
|---|-----------------|--------|-----|-----|------|
|   | $V_{DD}$ (V)    | min    | typ | max |      |
| $t_{PLH}$ : Propagation delay time<br>$t_{PHL}$ | 5               |        | 125 | 250 | ns   |
|   | 10              |        | 60  | 120 |      |
|   | 15              |        | 45  | 90  |      |
| $t_{THL}$ : Transition time<br>$t_{TLH}$        | 5               |        | 100 | 200 | ns   |
|   | 10              |        | 50  | 100 |      |
|   | 15              |        | 40  | 80  |      |

# DUAL "D" - TYPE FLIP-FLOP

## GENERAL DESCRIPTION

The MMC 4013 is a monolithic integrated circuit, available in 14-lead dual in-line plastic or ceramic package.

The MMP 4013 consists of two identical, independent data-type flip-flops. Each flip-flop has independent data, set, reset, and clock inputs and Q and  $\bar{Q}$  outputs. These devices can be used for shift register applications, and, by connecting  $\bar{Q}$  output to the data input, for counter and toggle applications. The logic level present at the D input is transferred to the Q output during the positive-going transition of the clock pulse. Setting or resetting is independent of the clock and is accomplished by a high level on the set or reset line, respectively.

## FEATURES

- set-reset capability
- static flip-flop operation — retains state indefinitely with clock level either "high" or "low"
- medium-speed operation — 16 MHz (typ.) clock toggle rate at 10 V
- quiescent current specified to 20 V
- maximum input leakage of 1  $\mu$ A at 18 V (full package temperature range)
- standardized symmetrical output characteristics
- 5 V, 10 V, and 15 V parametric ratings

## ABSOLUTE MAXIMUM RATINGS

|            |  |                    |                |                              |
|------------|--|--------------------|----------------|------------------------------|
| $V_{DD}^*$ | Supply voltage: G and H types<br>E and F types   | -0.5 to<br>-0.5 to | 20<br>18       | V<br>V                       |
| $V_i$      | Input voltage  | -0.5 to            | $V_{DD} + 0.5$ | V                            |
| $I_i$      | DC input current (any one input)   |                    | $\pm 10$       | mA                           |
| $P_{tot}$  | Total power dissipation (per package)<br>Dissipation per output transistor<br>for $T_A$ = full package-temperature range |                    | 200            | mW                           |
| $T_A$      | Operating temperature: G and H types<br>E and F types  | -55 to<br>-40 to   | 125<br>85      | $^{\circ}$ C<br>$^{\circ}$ C |
| $T_{stg}$  | Storage temperature  | -65 to             | 150            | $^{\circ}$ C                 |

\* All voltage values are referred to  $V_{SS}$  pin voltage

## RECOMMENDED OPERATING CONDITIONS

|            |   |                  |           |                              |
|------------|---|------------------|-----------|------------------------------|
| $V_{DD}^*$ | Supply voltage: G and H types<br>E and F types        | 3 to<br>3 to     | 18<br>15  | V<br>V                       |
| $V_i$      | Input voltage   | 0 to             | $V_{DD}$  | V                            |
| $T_A$      | Operating temperature: G and H types<br>E and F types | -55 to<br>-40 to | 125<br>85 | $^{\circ}$ C<br>$^{\circ}$ C |

## CONNECTION DIAGRAM

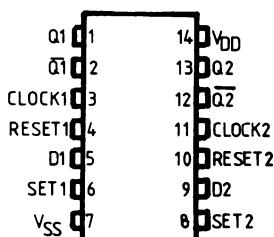

**STATIC ELECTRICAL CHARACTERISTICS**

(over recommended operating conditions)

| PARAMETER                         |                       | TEST CONDITIONS       |                       |                              |                        | VALUES             |       |           |       |                        |                     | UNIT  |         |    |
|-----------------------------------|-----------------------|-----------------------|-----------------------|------------------------------|------------------------|--------------------|-------|-----------|-------|------------------------|---------------------|-------|---------|----|
|                                   |                       | V <sub>I</sub><br>(V) | V <sub>O</sub><br>(V) | I <sub>O</sub><br>( $\mu$ A) | V <sub>DD</sub><br>(V) | T <sub>LOW</sub> * |       | 25°C      |       |                        | T <sub>HIGH</sub> * |       |         |    |
|                                   |                       |                       |                       |                              |                        | min.               | max.  | min.      | typ   | max.                   | min.                |       | max.    |    |
| I <sub>L</sub>                    | Quiescent current     | G, H types            | 0/ 5                  |                              |                        | 5                  |       | 1         |       | 0.02                   | 1                   |       | 30      |    |
|                                   |                       |                       | 0/10                  |                              |                        | 10                 |       | 2         |       | 0.02                   | 2                   |       | 60      |    |
|                                   |                       |                       | 0/15                  |                              |                        | 15                 |       | 4         |       | 0.02                   | 4                   |       | 120     |    |
|                                   |                       |                       | 0/20                  |                              |                        | 20                 |       | 20        |       | 0.04                   | 20                  |       | 600     |    |
|                                   |                       | E, F types            | 0/ 5                  |                              |                        | 5                  |       | 4         |       | 0.02                   | 4                   |       | 30      |    |
|                                   |                       |                       | 0/10                  |                              |                        | 10                 |       | 8         |       | 0.02                   | 8                   |       | 60      |    |
|                                   |                       |                       | 0/15                  |                              |                        | 15                 |       | 16        |       | 0.02                   | 16                  |       | 120     |    |
| V <sub>OH</sub>                   | Output high voltage   |                       | 0/ 5                  |                              | < 1                    | 5                  | 4.95  |           | 4.95  |                        |                     | 4.95  |         | V  |
|                                   |                       |                       | 0/10                  |                              | < 1                    | 10                 | 9.95  |           | 9.95  |                        |                     | 9.95  |         |    |
|                                   |                       |                       | 0/15                  |                              | < 1                    | 15                 | 14.95 |           | 14.95 |                        |                     | 14.95 |         |    |
| V <sub>OL</sub>                   | Output low voltage    |                       | 5 /0                  |                              | < 1                    | 5                  |       | 0.05      |       |                        | 0.05                |       | 0.05    | V  |
|                                   |                       |                       | 10/0                  |                              | < 1                    | 10                 |       | 0.05      |       |                        | 0.05                |       | 0.05    |    |
|                                   |                       |                       | 15/0                  |                              | < 1                    | 15                 |       | 0.05      |       |                        | 0.05                |       | 0.05    |    |
| V <sub>IH</sub>                   | Input high voltage    |                       |                       | 0.5/4.5                      | < 1                    | 5                  | 3.5   |           | 3.5   |                        |                     | 3.5   |         | V  |
|                                   |                       |                       |                       | 1/9                          | < 1                    | 10                 | 7     |           | 7     |                        |                     | 7     |         |    |
|                                   |                       |                       |                       | 1.5/13.5                     | < 1                    | 15                 | 11    |           | 11    |                        |                     | 11    |         |    |
| V <sub>IL</sub>                   | Input low voltage     |                       |                       | 4.5/0.5                      | < 1                    | 5                  |       | 1.5       |       |                        | 1.5                 |       | 1.5     | V  |
|                                   |                       |                       |                       | 9/1                          | < 1                    | 10                 |       | 3         |       |                        | 3                   |       | 3       |    |
|                                   |                       |                       |                       | 13.5/1.5                     | < 1                    | 15                 |       | 4         |       |                        | 4                   |       | 4       |    |
| I <sub>OH</sub>                   | Output drive current  | G, H types            | 0/ 5                  | 2.5                          |                        | 5                  | -2    |           | -1.6  | -3.2                   |                     | -1.15 |         |    |
|                                   |                       |                       | 0/ 5                  | 4.6                          |                        | 5                  | -0.64 |           | -0.51 | -1                     |                     | -0.36 |         |    |
|                                   |                       |                       | 0/10                  | 9.5                          |                        | 10                 | -1.6  |           | -1.3  | -2.6                   |                     | -0.9  |         |    |
|                                   |                       |                       | 0/15                  | 13.5                         |                        | 15                 | -4.2  |           | -3.4  | -6.8                   |                     | -2.4  |         |    |
|                                   |                       | E, F types            | 0/ 5                  | 2.5                          |                        | 5                  | -1.53 |           | -1.36 | -3.2                   |                     | -1.1  |         |    |
|                                   |                       |                       | 0/ 5                  | 4.6                          |                        | 5                  | -0.52 |           | -0.44 | -1                     |                     | -0.36 |         |    |
|                                   |                       |                       | 0/10                  | 9.5                          |                        | 10                 | -1.3  |           | -1.1  | -2.6                   |                     | -0.9  |         |    |
|                                   |                       |                       | 0/15                  | 13.5                         |                        | 15                 | -3.6  |           | -3.0  | -6.8                   |                     | -2.4  |         |    |
| I <sub>OL</sub>                   | Output sink current   | G, H types            | 0/ 5                  | 0.4                          |                        | 5                  | 0.64  |           | 0.51  | 1                      |                     | 0.36  |         |    |
|                                   |                       |                       | 0/10                  | 0.5                          |                        | 10                 | 1.6   |           | 1.3   | 2.6                    |                     | 0.9   |         |    |
|                                   |                       |                       | 0/15                  | 1.5                          |                        | 15                 | 4.2   |           | 3.4   | 6.8                    |                     | 2.4   |         |    |
|                                   |                       | E, F types            | 0/ 5                  | 0.4                          |                        | 5                  | 0.52  |           | 0.44  | 1                      |                     | 0.36  |         |    |
|                                   |                       |                       | 0/10                  | 0.5                          |                        | 10                 | 1.3   |           | 1.1   | 2.6                    |                     | 0.9   |         |    |
|                                   |                       |                       | 0/15                  | 1.5                          |                        | 15                 | 3.6   |           | 3.0   | 6.8                    |                     | 2.4   |         |    |
| I <sub>IH</sub> , I <sub>IL</sub> | Input leakage current | G, H types            | 0/18                  | Any input                    |                        | 18                 |       | $\pm$ 0.1 |       | $\pm$ 10 <sup>-5</sup> | $\pm$ 0.1           |       | $\pm$ 1 |    |
|                                   |                       | E, F types            | 0/15                  |                              |                        | 15                 |       | $\pm$ 0.3 |       | $\pm$ 10 <sup>-5</sup> | $\pm$ 0.3           |       | $\pm$ 1 |    |
| C <sub>I</sub>                    | Input capacitance     |                       |                       | Any input                    |                        |                    |       |           |       | 5                      | 7.5                 |       |         | pF |

\* T<sub>LOW</sub> = -55°C for G, H devices; -40°C for E, F devices.

\* T<sub>HIGH</sub> = +125°C for G, H devices; +85°C for E, F devices.

The Noise Margin for both "1" and "0" level is:

1 V min. with V<sub>DD</sub> = 5 V

2 V min. with V<sub>DD</sub> = 10 V

2.5 V min. with V<sub>DD</sub> = 15 V

**DYNAMIC ELECTRICAL CHARACTERISTICS**

( $T_A = 25^\circ\text{C}$ ,  $C_L = 50\text{ pF}$ ,  $R_L = 200\text{ kohm}$ , typical temperature coefficient for all  $V_{DD} = 0.3\%/^\circ\text{C}$  values, all input rise and fall time = 20 ns)

| PARAMETER  | TEST CONDITIONS<br>$V_{DD}$ (V) | VALUES          |                 |                   | UNIT          |
|--|---------------------------------|-----------------|-----------------|-------------------|---------------|
|  |                                 | min.            | typ.            | max.              |               |
| $t_{PLH}$ , $t_{PHL}$ Propagation delay time (clock to Q or Q outputs) | 5<br>10<br>15                   |                 | 150<br>65<br>45 | 300<br>130<br>90  | ns            |
| $t_{PLH}$ , Propagation delay time (Set to Q or Reset to $\bar{Q}$ )   | 5<br>10<br>15                   |                 | 150<br>65<br>45 | 300<br>130<br>90  | ns            |
| $t_{PHL}$ , Propagation delay time (Set to $\bar{Q}$ or Q outputs)     | 5<br>10<br>15                   |                 | 200<br>85<br>60 | 400<br>170<br>120 | ns            |
| $t_{TLH}$ , $t_{THL}$ Transition time                                  | 5<br>10<br>15                   |                 | 100<br>50<br>40 | 200<br>100<br>80  | ns            |
| $f_{CL}$ ● Maximum clock frequency                                     | 5<br>10<br>15                   | 3.5<br>8<br>12  | 7<br>16<br>24   |                   | MHz           |
| $t_W$ Clock pulse width  | 5<br>10<br>15                   | 140<br>60<br>40 | 70<br>30<br>20  |                   | ns            |
| $t_r$ , $t_f$ ●● Clock input rise or fall time                         | 5<br>10<br>15                   |                 |                 | 15<br>4<br>1      | $\mu\text{s}$ |
| $t_W$ Set or reset pulse width   | 5<br>10<br>15                   | 180<br>80<br>50 | 90<br>40<br>25  |                   | ns            |
| $t_{setup}$ Data setup time  | 5<br>10<br>15                   | 40<br>20<br>15  | 20<br>10<br>7   |                   | ns            |

- Input  $t_r$ ,  $t_f = 5\text{ ns}$
- If more than one unit is cascaded in a parallel clocked operation,  $t_r$  should be made less than or equal to the sum of the fixed propagation delay time at 15 pF and the transition time of the output driving stage for the estimated capacitive load.

**LOGIC DIAGRAM**

(one of two identical flip-flops)

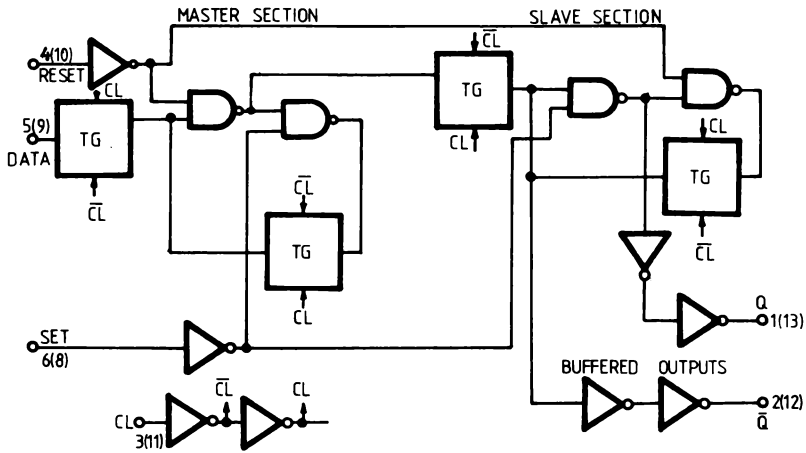

N(N) = FF1/FF2 TERMINAL ASSIGNMENT

**TRUTH TABLE**

| CL● | D | R | S | Q | $\bar{Q}$ |
|-----|---|---|---|---|-----------|
|     | 0 | 0 | 0 | 0 | 1         |
|     | 1 | 0 | 0 | 1 | 0         |
|     | X | 0 | 0 | Q | $\bar{Q}$ |
| X   | X | 1 | 0 | 0 | 1         |
| X   | X | 0 | 1 | 1 | 0         |
| X   | X | 1 | 1 | 1 | 1         |

NO CHANGE

LOGIC 0 = LOW  
LOGIC 1 = HIGH

● = LEVEL CHANGE  
X = DON'T CARE

# 8-STAGE STATIC SHIFT REGISTERS: SYNCHRONOUS PARALLEL OR SERIAL INPUT/SERIAL OUTPUT: MMC 4014 ASYNCHRONOUS PARALLEL INPUT OR SYNCHRONOUS SERIAL INPUT/SERIAL OUTPUT: MMC 4021

## GENERAL DESCRIPTION

The MMC 4014, MMC 4021 series types are 8-stage parallel-or serial-input/serial-output registers having common CLOCK and PARALLEL/SERIAL CONTROL inputs, a single SERIAL data input, and individual parallel "JAM" inputs to each register stage. Each register stage is a D type, master-slave flip-flop; in addition to an output from stage 8, "Q" outputs are also available from stage 6 and 7. Parallel as well as serial entry is made into the register synchronously with the positive clock line transition in the MMC 4014. In the MMC 4021 serial entry is synchronous with the clock but parallel entry is asynchronous.

In both types, entry is controlled by the PARALLEL/SERIAL CONTROL input.

When the PARALLEL/SERIAL CONTROL input is low, data is serially shifted into the 8-stage register synchronously with the positive transition of the clock line.

When the PARALLEL/SERIAL CONTROL input is high, data is jammed into the 8-stage register via the parallel input lines and synchronous with the positive transition of the clock line.

In the MMC 4021, the CLOCK input of the internal stage is "forced" when asynchronous parallel entry is made.

Register expansion using multiple package is permitted.

The MMC 4014, MMC 4021 series types are supplied in 16-lead dual-in-line plastic or ceramic package.

## FEATURES

- Medium speed operation-12 MHz (typ.) clock rate. at  $V_{DD}-V_{SS} = 10\text{ V}$
- Fully static operation
- 8 Master-Slave flip-flops plus output buffering and control gating

## ABSOLUTE MAXIMUM RATINGS

|            |  |  |  |
|------------|--|--|--|
| $V_{DD}^*$ | Supply voltage: G and H types<br>E and F types   | -0.5 to 20<br>-0.5 to 18<br>-0.5 to 10 | V<br>V<br>V                              |
| $V_i$      | Input voltage  | $V_{DD}+0.5$                           | V  |
| $I_i$      | DC input current (any one input)   | $\pm 10$                               | mA                                       |
| $P_{tot}$  | Total power dissipation (per package)  | 200                                    | mW                                       |
|            | Dissipation per output transistor<br>for $T_A = \text{full package-temperature range}$ | 100                                    | mW                                       |
| $T_A$      | Operating temperature: G and H types<br>E and F types                                  | -55 to 125<br>-40 to 85                | $^{\circ}\text{C}$<br>$^{\circ}\text{C}$ |
| $T_{stg}$  | Storage temperature  | -65 to 150                             | $^{\circ}\text{C}$                       |

\* All voltage values are referred to  $V_{SS}$  pin voltage

## RECOMMENDED OPERATING CONDITIONS

|            |   |                         |  |
|------------|---|-------------------------|--|
| $V_{DD}^*$ | Supply voltage: G and H types<br>E and F types        | 3 to 18<br>3 to 15      | V<br>V                                   |
| $V_i$      | Input voltage   | 0 to $V_{DD}$           | V  |
| $T_A$      | Operating temperature: G and H types<br>E and F types | -55 to 125<br>-40 to 85 | $^{\circ}\text{C}$<br>$^{\circ}\text{C}$ |

## CONNECTION DIAGRAM TRUTH TABLE

For 4014

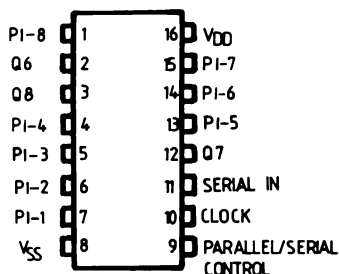

| CL | Serial input | Parallel/serial control | P I-1 | P I-n | $Q_1$<br>(internal) | $Q_n$     |
|----|--------------|-------------------------|-------|-------|---------------------|-----------|
|    | X            | 1                       | 0     | 0     | 0                   | 0         |
|    | X            | 1                       | 1     | 0     | 1                   | 0         |
|    | X            | 1                       | 0     | 1     | 0                   | 1         |
|    | X            | 1                       | 1     | 1     | 1                   | 1         |
|    | 0            | 0                       | X     | X     | 0                   | $Q_{n-1}$ |
|    | 1            | 0                       | X     | X     | 1                   | $Q_{n-1}$ |
|    | X            | X                       | X     | X     | $Q_1$               | $Q_n$     |

NC

X = Don't care case

NC = No change

LOGIC DIAGRAMS AND TRUTH TABLE

For MMC 4021

| CL | Serial input | Parallel/serial control | P I-1 | P I-n | Q <sub>1</sub> (internal) | Q <sub>n</sub>   |
|----|--------------|-------------------------|-------|-------|---------------------------|------------------|
| X  | X            | 1                       | 0     | 0     | 0                         | 0                |
| X  | X            | 1                       | 0     | 1     | 0                         | 1                |
| X  | X            | 1                       | 1     | 0     | 1                         | 0                |
| X  | X            | 1                       | 1     | 1     | 1                         | 1                |
|    | 0            | 0                       | X     | X     | 0                         | Q <sub>n-1</sub> |
|    | 1            | 0                       | X     | X     | 1                         | Q <sub>n-1</sub> |
|    | X            | 0                       | X     | X     | Q <sub>1</sub>            | Q <sub>n</sub>   |

X = Don't care case

NC = No change

MMC 4014

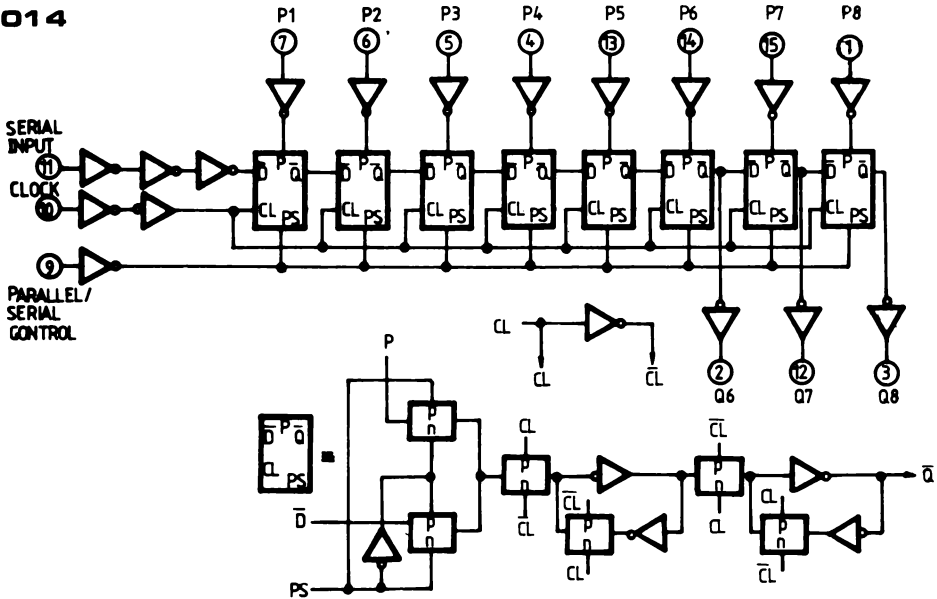

MMC 4021

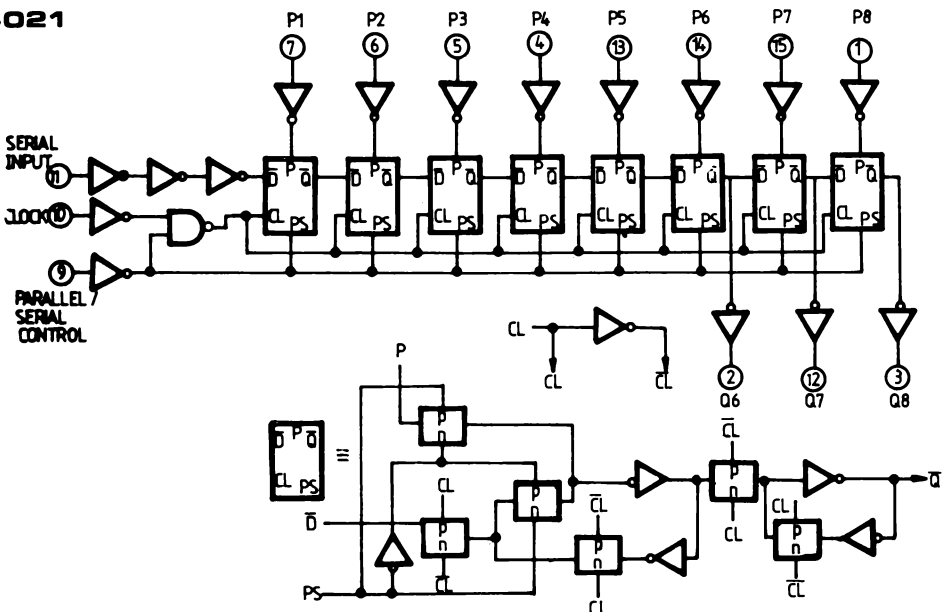



**STATIC ELECTRICAL CHARACTERISTICS**

(over recommended operating conditions)

| PARAMETER                       |                       | TEST CONDITIONS       |                       |                                 |                        | VALUES             |       |           |           |                        |                        | UNIT      |      |         |         |
|---------------------------------|-----------------------|-----------------------|-----------------------|---------------------------------|------------------------|--------------------|-------|-----------|-----------|------------------------|------------------------|-----------|------|---------|---------|
|                                 |                       | V <sub>I</sub><br>(V) | V <sub>O</sub><br>(V) | I <sub>OI</sub>  <br>( $\mu$ A) | V <sub>DD</sub><br>(V) | T <sub>LOW</sub> * |       | 25°C      |           |                        | T <sub>HIGH</sub> *    |           |      |         |         |
|                                 |                       |                       |                       |                                 |                        | min.               | max.  | min.      | typ       | max.                   | min.                   |           | max. |         |         |
| I <sub>L</sub>                  | Quiescent current     | G, H types            | 0/ 5                  |                                 |                        | 5                  |       | 5         |           | 0.04                   | 5                      |           | 150  | $\mu$ A |         |
|                                 |                       |                       | 0/10                  |                                 |                        | 10                 |       | 10        |           | 0.04                   | 10                     |           | 300  |         |         |
|                                 |                       |                       | 0/15                  |                                 |                        | 15                 |       | 20        |           | 0.04                   | 20                     |           | 600  |         |         |
|                                 |                       |                       | 0/20                  |                                 |                        | 20                 |       | 100       |           | 0.08                   | 100                    |           | 3000 |         |         |
|                                 |                       | E, F types            | 0/ 5                  |                                 |                        | 5                  |       | 20        |           | 0.04                   | 20                     |           | 150  |         |         |
|                                 |                       |                       | 0/10                  |                                 |                        | 10                 |       | 40        |           | 0.04                   | 40                     |           | 300  |         |         |
|                                 |                       |                       | 0/15                  |                                 |                        | 15                 |       | 80        |           | 0.04                   | 80                     |           | 600  |         |         |
| V <sub>OH</sub>                 | Output high voltage   |                       | 0/ 5                  |                                 | < 1                    | 5                  | 4.95  |           | 4.95      |                        | 4.95                   |           | V    |         |         |
|                                 |                       |                       | 0/10                  |                                 | < 1                    | 10                 | 9.95  |           | 9.95      |                        | 9.95                   |           |      |         |         |
|                                 |                       |                       | 0/15                  |                                 | < 1                    | 15                 | 14.95 |           | 14.95     |                        | 14.95                  |           |      |         |         |
| V <sub>OL</sub>                 | Output low voltage    |                       | 5 /0                  |                                 | < 1                    | 5                  |       | 0.05      |           | 0.05                   |                        | 0.05      | V    |         |         |
|                                 |                       |                       | 10/0                  |                                 | < 1                    | 10                 |       | 0.05      |           | 0.05                   |                        | 0.05      |      |         |         |
|                                 |                       |                       | 15/0                  |                                 | < 1                    | 15                 |       | 0.05      |           | 0.05                   |                        | 0.05      |      |         |         |
| V <sub>IH</sub>                 | Input high voltage    |                       |                       | 0.5/4.5                         | < 1                    | 5                  | 3.5   |           | 3.5       |                        | 3.5                    |           | V    |         |         |
|                                 |                       |                       |                       | 1/9                             | < 1                    | 10                 | 7     |           | 7         |                        | 7                      |           |      |         |         |
|                                 |                       |                       |                       | 1.5/13.5                        | < 1                    | 15                 | 11    |           | 11        |                        | 11                     |           |      |         |         |
| V <sub>IL</sub>                 | Input low voltage     |                       |                       | 4.5/0.5                         | < 1                    | 5                  |       | 1.5       |           | 1.5                    |                        | 1.5       | V    |         |         |
|                                 |                       |                       |                       | 9/1                             | < 1                    | 10                 |       | 3         |           | 3                      |                        | 3         |      |         |         |
|                                 |                       |                       |                       | 13.5/1.5                        | < 1                    | 15                 |       | 4         |           | 4                      |                        | 4         |      |         |         |
| I <sub>OH</sub>                 | Output drive current  | G, H types            | 0/ 5                  | 2.5                             |                        | 5                  | -2    |           | -1.6      | -3.2                   |                        | -1.15     | mA   |         |         |
|                                 |                       |                       | 0/ 5                  | 4.6                             |                        | 5                  | -0.64 |           | -0.51     | -1                     |                        | -0.36     |      |         |         |
|                                 |                       |                       | 0/10                  | 9.5                             |                        | 10                 | -1.6  |           | -1.3      | -2.6                   |                        | -0.9      |      |         |         |
|                                 |                       |                       | 0/15                  | 13.5                            |                        | 15                 | -4.2  |           | -3.4      | -6.8                   |                        | -2.4      |      |         |         |
|                                 |                       | E, F types            | 0/ 5                  | 2.5                             |                        | 5                  | -1.53 |           | -1.36     | -3.2                   |                        | -1.1      |      |         |         |
|                                 |                       |                       | 0/ 5                  | 4.6                             |                        | 5                  | -0.52 |           | -0.44     | -1                     |                        | -0.36     |      |         |         |
|                                 |                       |                       | 0/10                  | 9.5                             |                        | 10                 | -1.3  |           | -1.1      | -2.6                   |                        | -0.9      |      |         |         |
|                                 |                       |                       | 0/15                  | 13.5                            |                        | 15                 | -3.6  |           | 3.0       | -6.8                   |                        | -2.4      |      |         |         |
| I <sub>OL</sub>                 | Output sink current   | G, H types            | 0/ 5                  | 0.4                             |                        | 5                  | 0.64  |           | 0.51      | 1                      |                        | 0.36      | mA   |         |         |
|                                 |                       |                       | 0/10                  | 0.5                             |                        | 10                 | 1.6   |           | 1.3       | 2.6                    |                        | 0.9       |      |         |         |
|                                 |                       |                       | 0/15                  | 1.5                             |                        | 15                 | 4.2   |           | 3.4       | 6.8                    |                        | 2.4       |      |         |         |
|                                 |                       | E, F types            | 0/ 5                  | 0.4                             |                        | 5                  | 0.52  |           | 0.44      | 1                      |                        | 0.36      |      |         |         |
|                                 |                       |                       | 0/10                  | 0.5                             |                        | 10                 | 1.3   |           | 1.1       | 2.6                    |                        | 0.9       |      |         |         |
|                                 |                       |                       | 0/15                  | 1.5                             |                        | 15                 | 3.6   |           | 3.0       | 6.8                    |                        | 2.4       |      |         |         |
| I <sub>IH</sub> I <sub>IL</sub> | Input leakage current | G, H types            | 0/18                  | Any input                       |                        | 18                 |       | $\pm$ 0.1 |           | $\pm$ 10 <sup>-5</sup> | $\pm$ 0.1              |           |      | $\pm$ 1 | $\mu$ A |
|                                 |                       |                       | E, F types            |                                 | 0/15                   |                    | 15    |           | $\pm$ 0.3 |                        | $\pm$ 10 <sup>-5</sup> | $\pm$ 0.3 |      |         |         |
| C <sub>I</sub>                  | Input capacitance     |                       |                       | Any input                       |                        |                    |       |           |           | 5                      | 7.5                    |           | pF   |         |         |

\* T<sub>LOW</sub> = -55°C for G, H devices; -40°C for E, F devices.

\* T<sub>HIGH</sub> = +125°C for G, H devices; +85°C for E, F devices.

The Noise Margin for both "1" and "0" level is:

- 1 V min. with V<sub>DD</sub> = 5 V
- 2 V min. with V<sub>DD</sub> = 10 V
- 2.5 V min. with V<sub>DD</sub> = 15 V

**DYNAMIC ELECTRICAL CHARACTERISTICS**

( $T_A = 25^\circ\text{C}$ ,  $C_L = 50\text{ pF}$ ,  $R_L = 200\text{ kohm}$ , typical temperature coefficient for all  $V_{DD} = 0.3\%/^\circ\text{C}$  values, all input rise and fall times = 20 ns)

| PARAMETER   | TEST CONDITIONS | VALUES       |      |      | UNIT |               |
|---|-----------------|--------------|------|------|------|---------------|
|   |                 | $V_{DD}$ (V) | min. | typ. |      | max.          |
| <b>Clocked operation</b>  |                 |              |      |      |      |               |
| $t_{PLH}$ Propagation delay time<br>$t_{PHL}$                         |                 | 5            |      | 160  | 320  | ns            |
|   |                 | 10           |      | 80   | 160  |               |
|   |                 | 15           |      | 60   | 120  |               |
| $t_{THL}$ Transition time<br>$t_{TLH}$                                |                 | 5            |      | 100  | 200  | ns            |
|   |                 | 10           |      | 50   | 100  |               |
|   |                 | 15           |      | 40   | 80   |               |
| $f_{CL}^*$ Maximum clock input frequency                              |                 | 5            | 3    | 6    |      | MHz           |
|   |                 | 10           | 6    | 12   |      |               |
|   |                 | 15           | 8.5  | 17   |      |               |
| $t_W$ Clock pulse width   |                 | 5            | 180  | 90   |      | ns            |
|   |                 | 10           | 80   | 40   |      |               |
|   |                 | 15           | 50   | 25   |      |               |
| $t_r, t_f$ Clock input rise or fall time                              |                 | 5            |      |      | 15   | $\mu\text{s}$ |
|   |                 | 10           |      |      | 15   |               |
|   |                 | 15           |      |      | 15   |               |
| $t_{setup}$ Setup time, serial input (ref. to CL)                     |                 | 5            | 120  | 60   |      | ns            |
|   |                 | 10           | 80   | 40   |      |               |
|   |                 | 15           | 60   | 30   |      |               |
| $t_{setup}$ Setup time, parallel inputs (4014) (ref. to CL)           |                 | 5            | 80   | 40   |      | ns            |
|   |                 | 10           | 50   | 25   |      |               |
|   |                 | 15           | 40   | 20   |      |               |
| $t_{setup}$ Setup time, parallel inputs (4021)                        |                 | 5            | 50   | 25   |      | ns            |
|   |                 | 10           | 30   | 15   |      |               |
|   |                 | 15           | 20   | 10   |      |               |
| $t_{setup}$ Setup time, parallel/serial control (4014) (ref. to CL)   |                 | 5            | 180  | 90   |      | ns            |
|   |                 | 10           | 80   | 40   |      |               |
|   |                 | 15           | 60   | 30   |      |               |
| $t_{hold}$ Hold time, serial in, parallel in, parallel/serial control |                 | 5            | 0    |      |      | ns            |
|   |                 | 10           | 0    |      |      |               |
|   |                 | 15           | 0    |      |      |               |
| $t_{WH}$ P/S Pulse width (4021)                                       |                 | 5            | 160  | 80   |      | ns            |
|   |                 | 10           | 80   | 40   |      |               |
|   |                 | 15           | 50   | 25   |      |               |
| $t_{rem}$ P/S Removal, time (4021) (ref. to CL)                       |                 | 5            | 280  | 140  |      | ns            |
|   |                 | 10           | 140  | 70   |      |               |
|   |                 | 15           | 100  | 50   |      |               |

\* If more than one unit is cascaded  $t_{r,CL}$  should be made less than or equal to the sum of the transition time and the fixed propagation delay of the output of the driving stage for the estimated capacitive load.

# DUAL 4-STAGE STATIC SHIFT REGISTER WITH SERIAL INPUT/PARALLEL OUTPUT

## GENERAL DESCRIPTION

The MMC 4015 (G and H types) and MMC 4015 (E and F types) are monolithic integrated circuits, available in 16-lead dual in-line plastic or ceramic package.

The MMC 4015 consists of two identical, independent, 4-stage serial-input/parallel-output registers. Each register has independent CLOCK and RESET inputs as well as a single serial DATA input. "Q" outputs are available from each of the four stages on both registers. All register stages are D-type, master-slave flip-flops. The logic level present at the DATA inputs is transferred into the first register stage and shifted over one stage at each positive-going clock transition. Resetting of all stages is accomplished by a high level on the reset line. Register expansion to 8 stages using one MMC 4015 package, or to more than 8 stages using additional MMC 4015's is possible.

## FEATURES

- Medium speed operation: 12 MHz (typ.) clock rate at  $V_{DD}-V_{SS} = 10$  V.
- Fully static operation.
- 8 master-slave flip-flops plus input and output buffering
- High noise immunity

## ABSOLUTE MAXIMUM RATINGS

|            |  |  |  |
|------------|--|--|--|
| $V_{DD}^*$ | Supply voltage: G and H types<br>E and F types   | -0.5 to 20<br>-0.5 to 18<br>-0.5 to $V_{DD}+0.5$ | V<br>V<br>V                                    |
| $V_i$      | Input voltage  |  | V  |
| $I_i$      | DC input current (any one input)   |  | $\pm 10$ mA                                    |
| $P_{tot}$  | Total power dissipation (per package)<br>Dissipation per output transistor<br>for $T_A =$ full package-temperature range |  | 200 mW<br>100 mW                               |
| $T_A$      | Operating temperature :  | G and H types<br>E and F types                   | -55 to 125 °C<br>-40 to 85 °C<br>-65 to 150 °C |
| $T_{stg}$  | Storage temperature  |  |  |

\* All voltage values are referred to  $V_{SS}$  pin voltage

## RECOMMENDED OPERATING CONDITIONS

|            |  |                                     |                               |
|------------|--|-------------------------------------|-------------------------------|
| $V_{DD}^*$ | Supply voltage: G and H types<br>E and F types | 3 to 18<br>3 to 15<br>0 to $V_{DD}$ | V<br>V<br>V                   |
| $V_i$      | Input voltage                                  |                                     | V                             |
| $T_A$      | Operating temperature :                        | G and H types<br>E and F types      | -55 to 125 °C<br>-40 to 85 °C |

## CONNECTION DIAGRAM

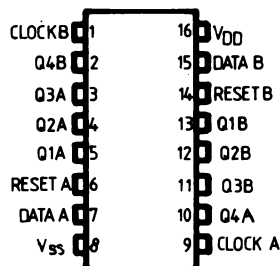

**STATIC ELECTRICAL CHARACTERISTICS**

(over recommended operating conditions)

| PARAMETER                         |                       | TEST CONDITIONS       |                       |                                |                        | VALUES             |       |           |       |                        |                     | UNIT  |         |         |
|-----------------------------------|-----------------------|-----------------------|-----------------------|--------------------------------|------------------------|--------------------|-------|-----------|-------|------------------------|---------------------|-------|---------|---------|
|                                   |                       | V <sub>I</sub><br>(V) | V <sub>O</sub><br>(V) | I <sub>O</sub>  <br>( $\mu$ A) | V <sub>DD</sub><br>(V) | T <sub>LOW</sub> * |       | 25°C      |       |                        | T <sub>HIGH</sub> * |       |         |         |
|                                   |                       |                       |                       |                                |                        | min.               | max.  | min.      | typ   | max.                   | min.                |       | max.    |         |
| I <sub>L</sub>                    | Quiescent current     | G, H types            | 0/ 5                  |                                |                        | 5                  |       | 5         |       | 0.04                   | 5                   |       | 150     |         |
|                                   |                       |                       | 0/10                  |                                |                        | 10                 |       | 10        |       | 0.04                   | 10                  |       | 300     |         |
|                                   |                       |                       | 0/15                  |                                |                        | 15                 |       | 20        |       | 0.04                   | 20                  |       | 600     |         |
|                                   |                       |                       | 0/20                  |                                |                        | 20                 |       | 100       |       | 0.08                   | 100                 |       | 3000    |         |
|                                   |                       | E, F types            | 0/ 5                  |                                |                        | 5                  |       | 20        |       | 0.04                   | 20                  |       | 150     |         |
|                                   |                       |                       | 0/10                  |                                |                        | 10                 |       | 40        |       | 0.04                   | 40                  |       | 300     |         |
|                                   |                       |                       | 0/15                  |                                |                        | 15                 |       | 80        |       | 0.04                   | 80                  |       | 600     |         |
| V <sub>OH</sub>                   | Output high voltage   |                       | 0/ 5                  |                                | < 1                    | 5                  | 4.95  |           | 4.95  |                        |                     | 4.95  |         | V       |
|                                   |                       |                       | 0/10                  |                                | < 1                    | 10                 | 9.95  |           | 9.95  |                        |                     | 9.95  |         |         |
|                                   |                       |                       | 0/15                  |                                | < 1                    | 15                 | 14.95 |           | 14.95 |                        |                     | 14.95 |         |         |
| V <sub>OL</sub>                   | Output low voltage    |                       | 5 /0                  |                                | < 1                    | 5                  |       | 0.05      |       |                        | 0.05                |       | 0.05    | V       |
|                                   |                       |                       | 10/0                  |                                | < 1                    | 10                 |       | 0.05      |       |                        | 0.05                |       | 0.05    |         |
|                                   |                       |                       | 15/0                  |                                | < 1                    | 15                 |       | 0.05      |       |                        | 0.05                |       | 0.05    |         |
| V <sub>IH</sub>                   | Input high voltage    |                       |                       | 0.5/4.5                        | < 1                    | 5                  | 3.5   |           | 3.5   |                        |                     | 3.5   |         | V       |
|                                   |                       |                       |                       | 1/9                            | < 1                    | 10                 | 7     |           | 7     |                        |                     | 7     |         |         |
|                                   |                       |                       |                       | 1.5/13.5                       | < 1                    | 15                 | 11    |           | 11    |                        |                     | 11    |         |         |
| V <sub>IL</sub>                   | Input low voltage     |                       |                       | 4.5/0.5                        | < 1                    | 5                  |       | 1.5       |       |                        | 1.5                 |       | 1.5     | V       |
|                                   |                       |                       |                       | 9/1                            | < 1                    | 10                 |       | 3         |       |                        | 3                   |       | 3       |         |
|                                   |                       |                       |                       | 13.5/1.5                       | < 1                    | 15                 |       | 4         |       |                        | 4                   |       | 4       |         |
| I <sub>OH</sub>                   | Output drive current  | G, H types            | 0/ 5                  | 2.5                            |                        | 5                  | -2    |           | -1.6  | -3.2                   |                     | -1.15 |         | mA      |
|                                   |                       |                       | 0/ 5                  | 4.6                            |                        | 5                  | -0.64 |           | -0.51 | -1                     |                     | -0.36 |         |         |
|                                   |                       |                       | 0/10                  | 9.5                            |                        | 10                 | -1.6  |           | -1.3  | -2.6                   |                     | -0.9  |         |         |
|                                   |                       |                       | 0/15                  | 13.5                           |                        | 15                 | -4.2  |           | -3.4  | -6.8                   |                     | -2.4  |         |         |
|                                   |                       | E, F types            | 0/ 5                  | 2.5                            |                        | 5                  | -1.53 |           | -1.36 | -3.2                   |                     | -1.1  |         |         |
|                                   |                       |                       | 0/ 5                  | 4.6                            |                        | 5                  | -0.52 |           | -0.44 | -1                     |                     | -0.36 |         |         |
|                                   |                       |                       | 0/10                  | 9.5                            |                        | 10                 | -1.3  |           | -1.1  | -2.6                   |                     | -0.9  |         |         |
|                                   |                       |                       | 0/15                  | 13.5                           |                        | 15                 | -3.6  |           | -3.0  | -6.8                   |                     | -2.4  |         |         |
| I <sub>OL</sub>                   | Output sink current   | G, H types            | 0/ 5                  | 0.4                            |                        | 5                  | 0.64  |           | 0.51  | 1                      |                     | 0.36  |         | mA      |
|                                   |                       |                       | 0/10                  | 0.5                            |                        | 10                 | 1.6   |           | 1.3   | 2.6                    |                     | 0.9   |         |         |
|                                   |                       |                       | 0/15                  | 1.5                            |                        | 15                 | 4.2   |           | 3.4   | 6.8                    |                     | 2.4   |         |         |
|                                   |                       | E, F types            | 0/ 5                  | 0.4                            |                        | 5                  | 0.52  |           | 0.44  | 1                      |                     | 0.36  |         |         |
|                                   |                       |                       | 0/10                  | 0.5                            |                        | 10                 | 1.3   |           | 1.1   | 2.6                    |                     | 0.9   |         |         |
|                                   |                       |                       | 0/15                  | 1.5                            |                        | 15                 | 3.6   |           | 3.0   | 6.8                    |                     | 2.4   |         |         |
| I <sub>IH</sub> , I <sub>IL</sub> | Input leakage current | G, H types            | 0/18                  | Any input                      |                        | 18                 |       | $\pm$ 0.1 |       | $\pm$ 10 <sup>-5</sup> | $\pm$ 0.1           |       | $\pm$ 1 | $\mu$ A |
|                                   |                       | E, F types            | 0/15                  |                                |                        | 15                 |       | $\pm$ 0.3 |       | $\pm$ 10 <sup>-5</sup> | $\pm$ 0.3           |       | $\pm$ 1 |         |
| C <sub>I</sub>                    | Input capacitance     |                       |                       | Any input                      |                        |                    |       |           |       | 5                      | 7.5                 |       |         | pF      |

\* T<sub>LOW</sub> = -55°C for G, H devices; -40°C for E, F devices.

\* T<sub>HIGH</sub> = +125°C for G, H devices; +85°C for E, F devices.

The Noise Margin for both "1" and "0" level is:

- 1 V min. with V<sub>DD</sub> = 5 V
- 2 V min. with V<sub>DD</sub> = 10 V
- 2.5 V min. with V<sub>DD</sub> = 15 V

**DYNAMIC ELECTRICAL CHARACTERISTICS**

( $T_A = 25^\circ\text{C}$ ,  $C_L = 50\text{ pF}$ ,  $R_L = 200\text{ kohm}$ , typical temperature coefficient for all  $V_{DD}$  values is  $0.3\%/^\circ\text{C}$ , all input rise and fall times =  $20\text{ ns}$ )

| PARAMETER                | TEST CONDITIONS<br>$V_{DD}$ (V)                         | VALUES        |                 |                 | UNIT              |               |
|--------------------------|---|---------------|-----------------|-----------------|-------------------|---------------|
|                          |   | min.          | typ.            | max.            |                   |               |
| <b>Clocked operation</b> |   |               |                 |                 |                   |               |
| $t_{PLH}$ ,<br>$t_{PHL}$ | Propagation delay time (Carry Out or Decoded out Lines) | 5<br>10<br>15 |                 | 160<br>80<br>60 | 320<br>160<br>120 | ns            |
| $t_{THL}$ ,<br>$t_{TLH}$ | Transition time (Carry Out or Decoded Out Lines)        | 5<br>10<br>15 |                 | 100<br>50<br>40 | 200<br>100<br>80  |               |
| $f_{CL}$                 | Maximum clock input frequency                           | 5<br>10<br>15 | 3<br>6<br>8.5   | 6<br>12<br>17   |                   | MHz           |
| $t_W$                    | Clock pulse width                                       | 5<br>10<br>15 | 180<br>80<br>50 | 90<br>40<br>25  |                   |               |
| $t_r$ , $t_f^{**}$       | Clock input rise or fall time                           | 5<br>10<br>15 |                 |                 | 15<br>15<br>15    | $\mu\text{s}$ |
| $t_{setup}$              | Data setup time   | 5<br>10<br>15 | 70<br>40<br>30  | 35<br>20<br>15  |                   |               |

**Reset operation**

|                          |                        |               |                 |                  |                   |    |
|--------------------------|------------------------|---------------|-----------------|------------------|-------------------|----|
| $t_{PLH}$ ,<br>$t_{PHL}$ | Propagation delay time | 5<br>10<br>15 |                 | 200<br>100<br>80 | 400<br>200<br>160 | ns |
| $t_W$                    | Reset pulse width      | 5<br>10<br>15 | 200<br>80<br>60 | 100<br>40<br>30  |                   |    |

\*\* If more than one unit is cascaded  $t_r$ , CL should be made less than or equal to the sum of the transition time and the fixed propagation delay of the output of the driving stage for the estimated capacitive load.

**LOGIC DIAGRAM**

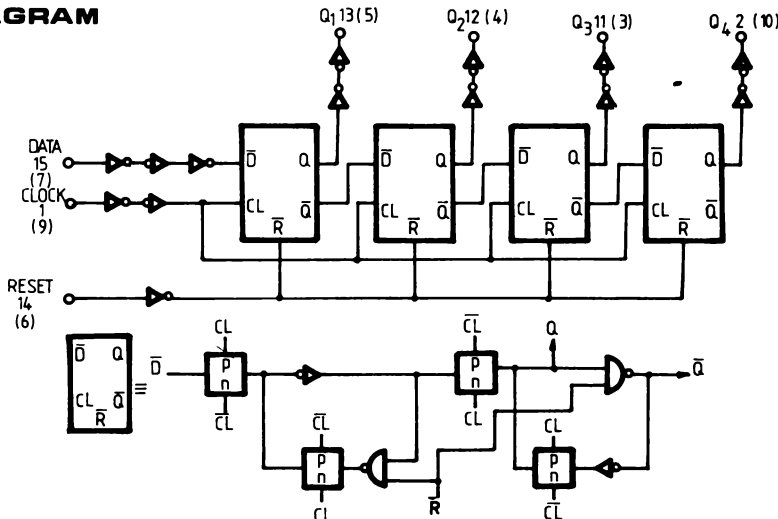

# QUAD BILATERAL SWITCH

## GENERAL DESCRIPTION

The MMC 4016 (intermediate or extended temperature range) are monolithic integrated circuit, available in 14-lead dual in-line plastic or ceramic package.

The MMC 4016 types are quad bilateral switches intended for the transmission or multiplexing of analog or digital signals. Each of the four independent bilateral switches has a single control signal input which simultaneously biases both the p and n device in a given switch ON or OFF.

## FEATURES

- 20 V digital or  $\pm 10$  V peak-to-peak switching
- 280 ohm typical ON resistance for 15 V operation
- Switch on resistance matched to within 10 ohm typ. over 15 V signal input range
- Extremely high control input impedance (control circuit isolated from signal circuit  $10^{12}$  ohm typ.)
- Extremely low off switch leakage resulting in very low offset current and high effective off resistance: 110 pA typ.  $V_{DD}, V_{SS} = 18$  V,  $T_A = 25^\circ\text{C}$
- Matched control-input to signal-output capacitance: reduces output signal transients.
- Frequency response switch on = 40 MHz (typ.).

## ABSOLUTE MAXIMUM RATINGS

|            |  |  |                 |                  |
|------------|--|--|-----------------|------------------|
| $V_{DD}^*$ | Supply voltage: G and H types<br>E and F types   | -0.5 to 20<br>-0.5 to 18<br>-0.5 to $V_{DD} + 0.5$ | 20<br>18<br>0.5 | V<br>V<br>V      |
| $V_i$      | Input voltage  |  |                 |                  |
| $I_i$      | DC input current (any one input)   |  | $\pm 10$        | mA               |
| $P_{tot}$  | Total power dissipation (per package)<br>Dissipation per output transistor<br>for $T_A =$ full package-temperature range |  | 200             | mW               |
| $T_A$      | Operating<br>temperature :   |  | 100             | mW               |
|            | G and H types  | -55 to 125   |                 | $^\circ\text{C}$ |
|            | E and F types  | -40 to 85  |                 | $^\circ\text{C}$ |
| $T_{stg}$  | Storage temperature  | -65 to 150   |                 | $^\circ\text{C}$ |

\* All voltage values are referred to  $V_{SS}$  pin voltage

## RECOMMENDED OPERATING CONDITIONS

|            |  |                                     |                      |                  |
|------------|--|-------------------------------------|----------------------|------------------|
| $V_{DD}^*$ | Supply voltage: G and H types<br>E and F types | 3 to 18<br>3 to 15<br>0 to $V_{DD}$ | 18<br>15<br>$V_{DD}$ | V<br>V<br>V      |
| $V_i$      | Input voltage                                  |                                     |                      |                  |
| $T_A$      | Operating<br>temperature :                     |                                     |                      |                  |
|            | G and H types                                  | -55 to 125                          |                      | $^\circ\text{C}$ |
|            | E and F types                                  | -40 to 85                           |                      | $^\circ\text{C}$ |

## CONNECTION DIAGRAM

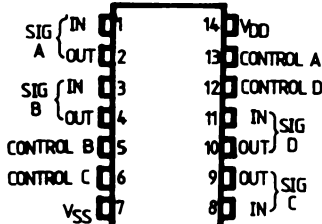

## SCHEMATIC DIAGRAM

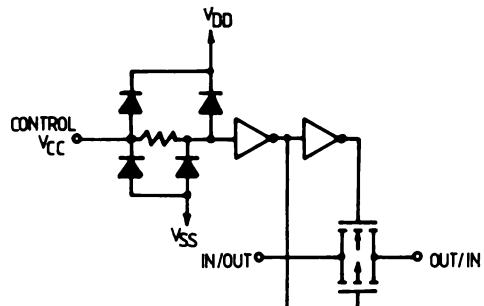

**TYPICAL „ON“ RESISTANCE CHARACTERISTICS,**

T<sub>A</sub> = 25°C.

| CHARACTERISTIC*        | SUPPLY CONDITIONS   |                     | LOAD CONDITIONS       |                     |                        |                     |                         |                     |
|------------------------|---------------------|---------------------|-----------------------|---------------------|------------------------|---------------------|-------------------------|---------------------|
|                        |                     |                     | R <sub>L</sub> = 1 kΩ |                     | R <sub>L</sub> = 10 kΩ |                     | R <sub>L</sub> = 100 kΩ |                     |
|                        | V <sub>DD</sub> (V) | V <sub>SS</sub> (V) | VALUE (Ω)             | V <sub>IS</sub> (V) | VALUE (Ω)              | V <sub>IS</sub> (V) | VALUE (Ω)               | V <sub>IS</sub> (V) |
| R <sub>ON</sub>        | +15                 | 0                   | 200<br>200            | +15<br>0            | 200<br>200             | +15<br>0            | 180<br>200              | +15<br>0            |
| R <sub>ON</sub> (max.) | +15                 | 0                   | 300                   | +11                 | 300                    | +9.3                | 320                     | +9.2                |
| R <sub>ON</sub>        | +10                 | 0                   | 290<br>290            | +10<br>0            | 250<br>250             | +10<br>0            | 240<br>300              | +10<br>0            |
| R <sub>ON</sub> (max.) | +10                 | 0                   | 500                   | +7.4                | 560                    | +5.6                | 610                     | +5.5                |
| R <sub>ON</sub>        | +5                  | 0                   | 860<br>600            | +5<br>0             | 470<br>580             | +5<br>0             | 450<br>800              | +5<br>0             |
| R <sub>ON</sub> (max.) | +5                  | 0                   | 1.7 k                 | +4.2                | 7k                     | +2.9                | 33 k                    | +2.7                |
| R <sub>ON</sub>        | +2.5                | -2.5                | 590<br>720            | +2.5<br>-2.5        | 450<br>520             | +2.5<br>-2.5        | 490<br>520              | +2.5<br>-2.5        |
| R <sub>ON</sub> (max.) | +2.5                | -2.5                | 232 k                 | ± 0.25              | 300 k                  | ± 0.25              | 870 k                   | ± 0.25              |

\* Variation from a perfect switch, R<sub>ON</sub> = 0 Ω

**STATIC ELECTRICAL CHARACTERISTICS**

(over recommended operating conditions)

| PARAMETER   |            | TEST CONDITIONS                  |                     |                     | VALUES           |      |      |     |      |                   | UNIT |      |
|---|------------|----------------------------------|---------------------|---------------------|------------------|------|------|-----|------|-------------------|------|------|
|   |            | V <sub>C</sub> = V <sub>DD</sub> | V <sub>SS</sub> (V) | V <sub>DD</sub> (V) | T <sub>LOW</sub> |      | 25°C |     |      | T <sub>HIGH</sub> |      |      |
|   |            |                                  |                     |                     | min.             | max. | min. | typ | max. | min.              |      | max. |
| I <sub>L</sub> Quiescent device current (all switches ON or all switches OFF) | G, H types |                                  |                     | 5                   |                  |      | 0.25 |     | 0.01 | 0.25              |      | 7.5  |
|   |            |                                  |                     | 10                  |                  |      | 0.5  |     | 0.01 | 0.5               |      | 15   |
|   |            |                                  |                     | 15                  |                  |      | 1    |     | 0.01 | 1                 |      | 30   |
|   |            |                                  |                     | 20                  |                  |      | 5    |     | 0.02 | 5                 |      | 150  |
|   | E, F types |                                  |                     | 5                   |                  |      | 1    |     | 0.01 | 1                 |      | 7.5  |
|   |            |                                  |                     | 10                  |                  |      | 2    |     | 0.01 | 2                 |      | 15   |
|   |            |                                  |                     | 15                  |                  |      | 4    |     | 0.01 | 4                 |      | 30   |

**Switch**

| R <sub>ON</sub> ON Resistance | H, G types | R <sub>L</sub> = 10 kΩ | +7.5 | -7.5 | V <sub>IS</sub>       | 360         | 200        | 400         | 600         |
|-------------------------------|------------|------------------------|------|------|-----------------------|-------------|------------|-------------|-------------|
|                               |            |                        |      |      | +7.5<br>-7.5<br>±0.25 |             |            |             |             |
| E, F types                    |            |                        |      |      | +7.5                  | 370         | 200        | 400         | 520         |
|                               |            |                        |      |      | -7.5<br>+0.25         | 370<br>790  | 200<br>280 | 400<br>850  | 520<br>1080 |
| H, G types                    |            | R <sub>L</sub> = 10 kΩ | +5   | -5   | +5                    | 600         | 250        | 660         | 960         |
|                               |            |                        |      |      | -5<br>±0.25           | 600<br>1870 | 250<br>580 | 660<br>2000 | 960<br>2600 |
| E, F types                    |            |                        |      |      | +5                    | 610         | 250        | 660         | 840         |
|                               |            |                        |      |      | -5<br>±0.25           | 610<br>1900 | 250<br>580 | 660<br>2000 | 840<br>2380 |

**STATIC ELECTRICAL CHARACTERISTICS**

(over recommended operating conditions)

| PARAMETER   |            | TEST CONDITIONS           |                  |              |                      | VALUES      |                   |             |                     |                   |             | UNIT               |              |                  |   |                      |  |                   |           |                   |                   |   |                    |     |   |                      |  |                    |  |                   |                    |  |                    |
|---|------------|---------------------------|------------------|--------------|----------------------|-------------|-------------------|-------------|---------------------|-------------------|-------------|--------------------|--------------|------------------|---|----------------------|--|-------------------|-----------|-------------------|-------------------|---|--------------------|-----|---|----------------------|--|--------------------|--|-------------------|--------------------|--|--------------------|
|   |            |                           | $V_C = V_{DD}$   | $V_{SS}$ (V) | $V_{DD}$ (V)         | $T_{LOW}$   |                   | 25°C        |                     |                   | $T_{HIGH}$  |                    |              |                  |   |                      |  |                   |           |                   |                   |   |                    |     |   |                      |  |                    |  |                   |                    |  |                    |
|   |            |                           |                  |              |                      | min.        | max.              | min.        | typ                 | max.              | min.        |                    | max.         |                  |   |                      |  |                   |           |                   |                   |   |                    |     |   |                      |  |                    |  |                   |                    |  |                    |
|   | G, H types | $R_L = 10\text{ k}\Omega$ | +15              | 0            | +15<br>+0.25<br>+9.3 |             | 360<br>360<br>775 |             | 200<br>200<br>300   | 400<br>400<br>850 |             | 600<br>600<br>1230 | $\Omega$     |                  |   |                      |  |                   |           |                   |                   |   |                    |     |   |                      |  |                    |  |                   |                    |  |                    |
|   | E, F types |                           |                  |              |                      |             |                   |             |                     |                   |             |                    |              | +15              | 0 | +15<br>+0.25<br>+9.3 |  | 370<br>370<br>790 |           | 200<br>200<br>300 | 400<br>400<br>800 |   | 520<br>520<br>1080 |     |   |                      |  |                    |  |                   |                    |  |                    |
|   | G, H types |                           |                  |              |                      |             |                   |             |                     |                   |             |                    |              |                  |   |                      |  |                   |           |                   |                   |   |                    | +10 | 0 | +10<br>+0.25<br>+5.6 |  | 600<br>600<br>1870 |  | 250<br>250<br>560 | 660<br>660<br>2000 |  | 960<br>960<br>2600 |
|   | E, F types |                           |                  |              |                      |             |                   |             |                     |                   |             |                    |              |                  |   |                      |  |                   |           |                   |                   |   |                    |     |   |                      |  |                    |  |                   |                    |  |                    |
| $\Delta ON$ Resistance<br>(between any 2 of 4 switches)                     |            | $R_L = 10\text{ k}\Omega$ | +7.5<br>+5       | -7.5<br>-5   | $\pm 7.5$<br>$\pm 5$ |             |                   | 10<br>15    |                     |                   |             | $\Omega$           |              |                  |   |                      |  |                   |           |                   |                   |   |                    |     |   |                      |  |                    |  |                   |                    |  |                    |
| Input or output leakage current switch OFF (effective OFF resistance)       | G, H types |                           |                  |              |                      |             |                   |             |                     |                   |             |                    | $V_{DD} +18$ | $V_C = V_{SS} 0$ |   |                      |  | $\pm 0.1$         | $10^{-5}$ | $\pm 0.1$         |                   | 1 | $\mu A$            |     |   |                      |  |                    |  |                   |                    |  |                    |
|   | E, F types | $V_{DD} +15$              | $V_C = V_{SS} 0$ |              |                      |             | $\pm 0.3$         | $10^{-5}$   | $\pm 0.3$           |                   | 1           |                    |              |                  |   |                      |  |                   |           |                   |                   |   |                    |     |   |                      |  |                    |  |                   |                    |  |                    |
| $C_I$ Input capacitance<br>$C_O$ Output capacitance<br>$C_{IO}$ Feedthrough |            | $V_{CC} = V_{SS} = -5$    |                  |              | +5                   |             |                   |             | 4<br>4<br>0.2       |                   |             |                    | pF           |                  |   |                      |  |                   |           |                   |                   |   |                    |     |   |                      |  |                    |  |                   |                    |  |                    |
| <b>Control (<math>V_C</math>)</b>   |            |                           |                  |              |                      |             |                   |             |                     |                   |             |                    |              |                  |   |                      |  |                   |           |                   |                   |   |                    |     |   |                      |  |                    |  |                   |                    |  |                    |
| $V_{TH}$ Switch threshold voltage   |            | $I_{IS} = 10\ \mu A$      |                  |              | 5<br>10<br>15        | 1<br>2<br>2 |                   | 1<br>2<br>2 | 2.25<br>4.5<br>6.75 |                   | 1<br>2<br>2 |                    | V            |                  |   |                      |  |                   |           |                   |                   |   |                    |     |   |                      |  |                    |  |                   |                    |  |                    |
| $I_I$ Input current   | G, H types | $V_{IS} \leq V_{DD}$      |                  |              | 18                   |             | $\pm 0.1$         |             | $\pm 10^{-5}$       | $\pm 0.1$         |             | $\pm 1$            | $\mu A$      |                  |   |                      |  |                   |           |                   |                   |   |                    |     |   |                      |  |                    |  |                   |                    |  |                    |
|   | E, F types |                           |                  |              | 15                   |             | $\pm 0.3$         |             | $\pm 10^{-5}$       | $\pm 0.3$         |             | $\pm 1$            |              |                  |   |                      |  |                   |           |                   |                   |   |                    |     |   |                      |  |                    |  |                   |                    |  |                    |
| $C_I$ Input capacitance   |            |                           |                  |              |                      |             |                   | 5           | 7.5                 |                   |             | pF                 |              |                  |   |                      |  |                   |           |                   |                   |   |                    |     |   |                      |  |                    |  |                   |                    |  |                    |



**DYNAMIC ELECTRICAL CHARACTERISTICS**

(T<sub>A</sub> = 25°C, C<sub>L</sub> = 50 pF all input square wave rise and fall time = 20 ns).

| PARAMETER  | V <sub>C</sub> (V)   | TEST CONDITIONS     |                       |                                    |                     |                     | VALUES                                  |                |                 | UNIT |
|--|--|---------------------|-----------------------|------------------------------------|---------------------|---------------------|---|----------------|-----------------|------|
|  |  | R <sub>L</sub> (kΩ) | f <sub>i</sub> (KHz.) | V <sub>i</sub> (V)                 | V <sub>SS</sub> (V) | V <sub>DD</sub> (V) | typ.                                    | max.           |                 |      |
| <b>Switch</b>  |  |                     |                       |                                    |                     |                     |   |                |                 |      |
| t <sub>pd</sub> Propagation delay time (Signal input to output)                                | = V <sub>DD</sub>  | 10                  |                       | 10 sq. Wave                        | GND                 | 5<br>10<br>15       |   | 40<br>20<br>15 | 100<br>50<br>40 | ns   |
| Crosstalk between any 2 of 4 switches<br>(f -50 dB) $20 \log \frac{V_O}{V_I} = -50 \text{ dB}$ | V <sub>C(A)</sub> = V <sub>DD</sub> = +5<br>V <sub>C(B)</sub> = V <sub>SS</sub> = -5 | 1                   |                       | V <sub>I(A)</sub> = 5pp            |                     |                     |   | 0.9            |                 | MHz  |
| Frequency response switch "ON" (Sine wave input) at $20 \log \frac{V_O}{V_I} = -3 \text{ dB}$  | = V <sub>DD</sub><br>= +5  | 1                   |                       | 5p-p                               | -5                  |                     |   | 40             |                 | MHz  |
| Feedthrough (Switch OFF) at $20 \log \frac{V_O}{V_I} = -50 \text{ dB}$                         | = V <sub>SS</sub><br>= -5  | 1                   |                       | -5p-p                              |                     | 5                   |   | 1.25           |                 | MHz  |
| Sine wave distortion   | = V <sub>DD</sub><br>= 5   | 10                  | 1                     | 5p-p                               | -5                  |                     |   | 0.4            |                 | %    |
| <b>Control (V<sub>C</sub>)</b>   |  |                     |                       |                                    |                     |                     |   |                |                 |      |
| Propagation delay: (Turn ON control to output)   | V <sub>DD</sub> - V <sub>SS</sub> (Sq. wave)   | 1                   |                       | V <sub>DD</sub> or V <sub>SS</sub> |                     | 5<br>10<br>15       | V <sub>DD</sub> -V <sub>SS</sub> = 10 V | 35<br>20<br>15 | 70<br>40<br>30  | ns   |
| Max. allowable control input repetition rate   | 10 (Sq. wave)  | 1                   |                       | V <sub>DD</sub>                    | GND                 | 10                  |   | 10             |                 | MHz  |
| Crosstalk (Control input to signal output)   | 10 (Sq. wave)  | 10                  |                       |                                    | GND                 | 10                  |   | 50             |                 | mV   |

- (▲) Symetrical about OV
- (●) Fir all test conditions.

# COUNTER/DIVIDERS: 4017` DECADE COUNTER WITH 10 DECODED OUTPUTS 4022 OCTAL COUNTER WITH 8 DECODED OUTPUTS

## GENERAL DESCRIPTION

The MMC 4017 and MMC 4022 are 5-stage and 4 stage Johnson counters having 10 and 8 decoded outputs respectively.

The MMC 4017 and MMC 4022 are monolithic integrated circuits, fabricated in standard Al-gate CMOS technology. Are available in 16-lead dual in-line plastic package.

Inputs include a CLOCK, a RESET and a CLOCK inhibit signal. Schmitt trigger in the CLOCK input circuit provides pulse shaping that allows unlimited clock input pulse rise and fall times. These counters are advanced one count at the positive clock signal transition if the CLOCK INHIBIT signal is low. Counter advancement via the clock line is inhibited when the CLOCK INHIBIT signal is high. A high RESET signal clears the counter to its zero count. Use of the Johnson decade-counter configuration permits high-speed operation. 2-input decimal-decode gating and spike-free decoded outputs. Anti-lock gating is provided, thus assuring proper counting sequence. The

decoded outputs are normally low and go high only at their respective decoded time slot. Each decoded Output remains high for one full clock cycle. A CARRY-OUT signal completes one cycle every 10 clock input cycles in the MMC 4017 or every 8 clock input cycles in the MMC 4022 and is used to ripple-clock the succeeding device in a multi-device counting chain.

## FEATURES

- Fully static operation
- Medium speed operation — 12 MHz (typ) at  $V_{DD} = 10\text{ V}$

## APPLICATIONS

- Decade counter/decimal decode display
- Binary counter/decoder
- Frequency division
- Counter control/timers
- Divide — by — N counting.

## ABSOLUTE MAXIMUM RATINGS

|            |  |                                |                            |                 |
|------------|--|--------------------------------|----------------------------|-----------------|
| $V_{DD}^*$ | Supply voltage: G and H types<br>E and F types   | -0.5 to<br>-0.5 to<br>-0.5 to  | 20<br>18<br>$V_{DD} + 0.5$ | V<br>V<br>V     |
| $V_i$      | Input voltage  |                                |                            | V               |
| $I_i$      | DC input current (any one input)   |                                | $\pm 10$                   | mA              |
| $P_{tot}$  | Total power dissipation (per package)<br>Dissipation per output transistor<br>for $T_A =$ full package-temperature range |                                | 200                        | mW              |
| $T_A$      | Operating<br>temperature :   | G and H types<br>E and F types | -55 to<br>-40 to           | 125<br>85<br>°C |
| $T_{stg}$  | Storage temperature  |                                | -65 to                     | 150<br>°C       |

\* All voltage values are referred to  $V_{SS}$  pin voltage

## RECOMMENDED OPERATING CONDITIONS

|            |  |                                |                  |                 |
|------------|--|--------------------------------|------------------|-----------------|
| $V_{DD}^*$ | Supply voltage: G and H types<br>E and F types | 3 to<br>3 to                   | 18<br>15         | V<br>V          |
| $V_i$      | Input voltage                                  | 0 to                           | $V_{DD}$         | V               |
| $T_A$      | Operating<br>temperature :                     | G and H types<br>E and F types | -55 to<br>-40 to | 125<br>85<br>°C |

## CONNECTION DIAGRAMS

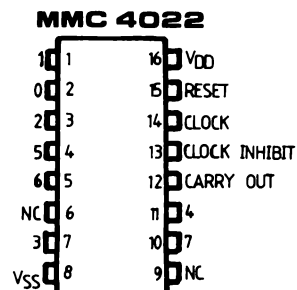
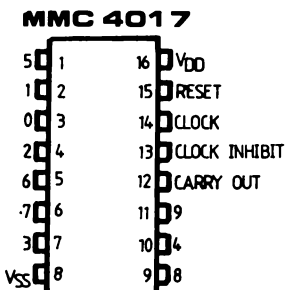

LOGIC DIAGRAM

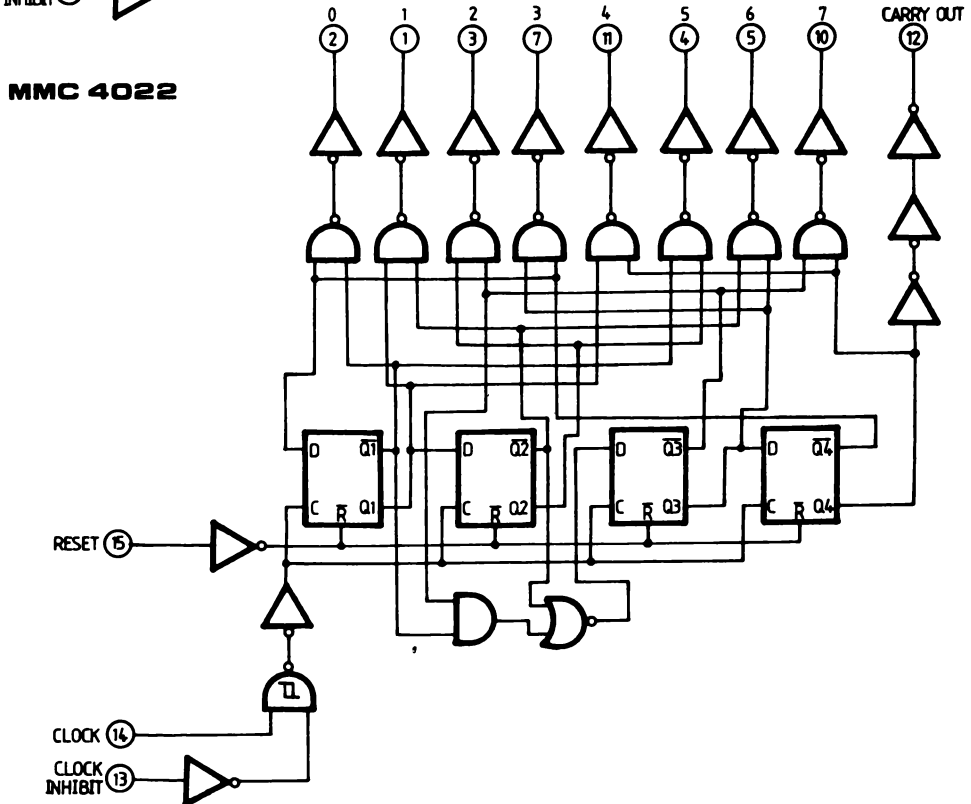
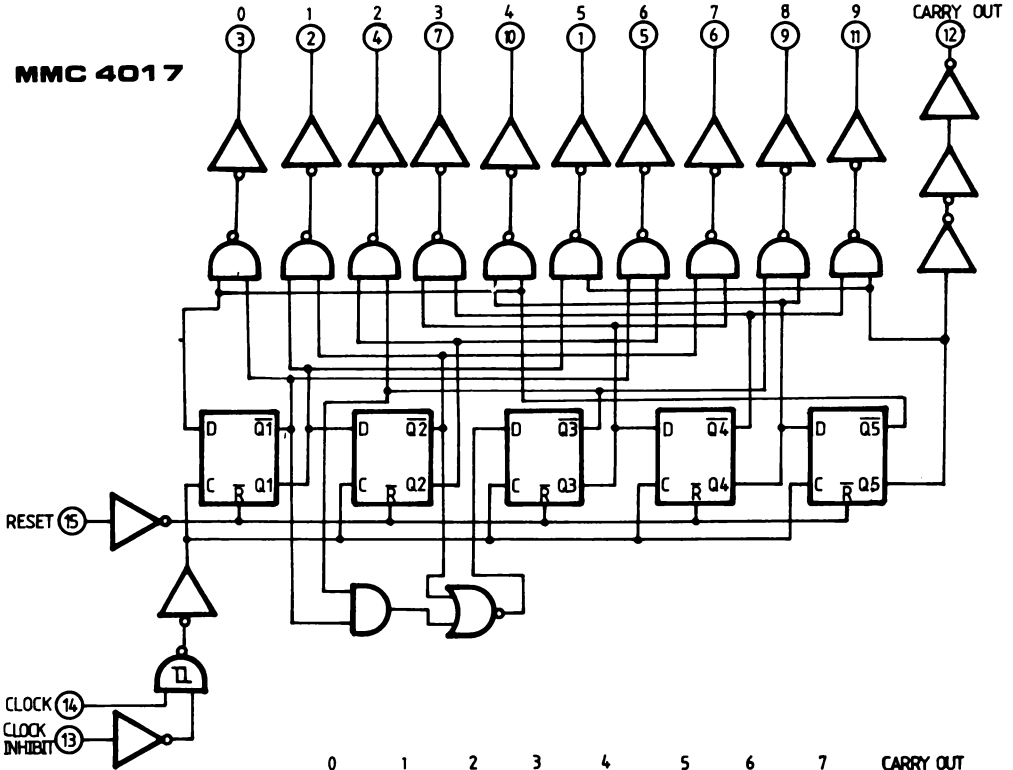

TIMING DIAGRAM

MMC 4017

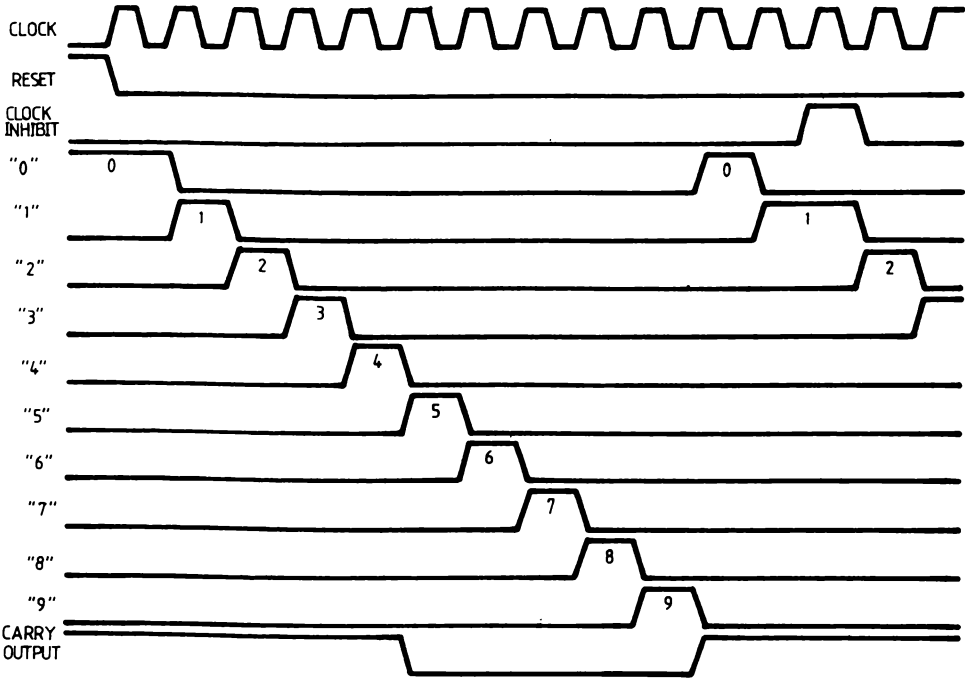

MMC 4022

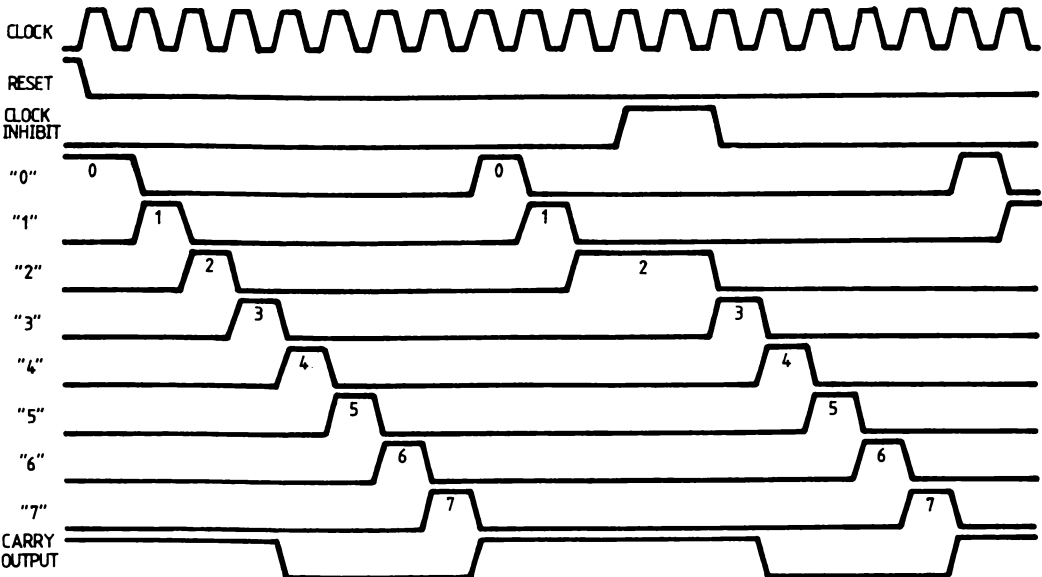

**STATIC ELECTRICAL CHARACTERISTICS**

(over recommended operating conditions)

| PARAMETER                         |                       | TEST CONDITIONS       |                       |                                     |                        | VALUES                        |       |       |       |                   |                                | UNIT  |      |    |
|-----------------------------------|-----------------------|-----------------------|-----------------------|-------------------------------------|------------------------|-------------------------------|-------|-------|-------|-------------------|--------------------------------|-------|------|----|
|                                   |                       | V <sub>I</sub><br>(V) | V <sub>O</sub><br>(V) | I <sub>O</sub> <sup>†</sup><br>(μA) | V <sub>DD</sub><br>(V) | T <sub>LOW</sub> <sup>*</sup> |       | 25°C  |       |                   | T <sub>HIGH</sub> <sup>*</sup> |       |      |    |
|                                   |                       |                       |                       |                                     |                        | min.                          | max.  | min.  | typ   | max.              | min.                           |       | max. |    |
| I <sub>L</sub>                    | Quiescent current     | G, H types            | 0/ 5                  |                                     |                        | 5                             |       | 5     |       | 0.04              | 5                              |       | 150  |    |
|                                   |                       |                       | 0/10                  |                                     |                        | 10                            |       | 10    |       | 0.04              | 10                             |       | 300  |    |
| 0/15                              |                       |                       |                       |                                     | 15                     |                               | 20    |       | 0.04  | 20                |                                | 600   |      |    |
| 0/20                              |                       |                       |                       |                                     | 20                     |                               | 100   |       | 0.08  | 100               |                                | 3000  |      |    |
|                                   | E, F types            | 0/ 5                  |                       |                                     | 5                      |                               | 20    |       | 0.04  | 20                |                                | 150   |      |    |
| 0/10                              |                       |                       |                       | 10                                  |                        | 40                            |       | 0.04  | 40    |                   | 300                            |       |      |    |
| 0/15                              |                       |                       |                       | 15                                  |                        | 80                            |       | 0.04  | 80    |                   | 600                            |       |      |    |
| V <sub>OH</sub>                   | Output high voltage   | 0/ 5                  |                       | < 1                                 | 5                      | 4.95                          |       | 4.95  |       |                   | 4.95                           |       | V    |    |
|                                   |                       | 0/10                  |                       | < 1                                 | 10                     | 9.95                          |       | 9.95  |       |                   | 9.95                           |       |      |    |
|                                   |                       | 0/15                  |                       | < 1                                 | 15                     | 14.95                         |       | 14.95 |       |                   | 14.95                          |       |      |    |
| V <sub>OL</sub>                   | Output low voltage    | 5 /0                  |                       | < 1                                 | 5                      |                               | 0.05  |       |       | 0.05              |                                | 0.05  | V    |    |
|                                   |                       | 10/0                  |                       | < 1                                 | 10                     |                               | 0.05  |       |       | 0.05              |                                | 0.05  |      |    |
|                                   |                       | 15/0                  |                       | < 1                                 | 15                     |                               | 0.05  |       |       | 0.05              |                                | 0.05  |      |    |
| V <sub>IH</sub>                   | Input high voltage    |                       | 0.5/4.5               | < 1                                 | 5                      | 3.5                           |       | 3.5   |       |                   | 3.5                            |       | V    |    |
|                                   |                       |                       | 1/9                   | < 1                                 | 10                     | 7                             |       | 7     |       |                   | 7                              |       |      |    |
|                                   |                       |                       | 1.5/13.5              | < 1                                 | 15                     | 11                            |       | 11    |       |                   | 11                             |       |      |    |
| V <sub>IL</sub>                   | Input low voltage     |                       | 4.5/0.5               | < 1                                 | 5                      |                               | 1.5   |       |       | 1.5               |                                | 1.5   | V    |    |
|                                   |                       |                       | 9/1                   | < 1                                 | 10                     |                               | 3     |       |       | 3                 |                                | 3     |      |    |
|                                   |                       |                       | 13.5/1.5              | < 1                                 | 15                     |                               | 4     |       |       | 4                 |                                | 4     |      |    |
| I <sub>OH</sub>                   | Output drive current  | G, H types            | 0/ 5                  | 2.5                                 |                        | 5                             | -2    |       | -1.6  | -3.2              |                                | -1.15 | mA   |    |
|                                   |                       |                       | 0/ 5                  | 4.6                                 |                        | 5                             | -0.64 |       | -0.51 | -1                |                                | -0.36 |      |    |
| 0/10                              |                       |                       | 9.5                   |                                     | 10                     | -1.6                          |       | -1.3  | -2.6  |                   | -0.9                           |       |      |    |
| 0/15                              |                       |                       | 13.5                  |                                     | 15                     | -4.2                          |       | -3.4  | -6.8  |                   | -2.4                           |       |      |    |
| E, F types                        |                       | 0/ 5                  | 2.5                   |                                     | 5                      | -1.53                         |       | -1.36 | -3.2  |                   | -1.1                           |       |      |    |
|                                   |                       | 0/ 5                  | 4.6                   |                                     | 5                      | -0.52                         |       | -0.44 | -1    |                   | -0.36                          |       |      |    |
|                                   | E, F types            | 0/10                  | 9.5                   |                                     | 10                     | -1.3                          |       | -1.1  | -2.6  |                   | -0.9                           |       |      |    |
|                                   |                       | 0/15                  | 13.5                  |                                     | 15                     | -3.6                          |       | -3.0  | -6.8  |                   | -2.4                           |       |      |    |
| I <sub>OL</sub>                   | Output sink current   | G, H types            | 0/ 5                  | 0.4                                 |                        | 5                             | 0.64  |       | 0.51  | 1                 |                                | 0.36  | mA   |    |
|                                   |                       |                       | 0/10                  | 0.5                                 |                        | 10                            | 1.6   |       | 1.3   | 2.6               |                                | 0.9   |      |    |
| 0/15                              |                       |                       | 1.5                   |                                     | 15                     | 4.2                           |       | 3.4   | 6.8   |                   | 2.4                            |       |      |    |
| E, F types                        |                       | 0/ 5                  | 0.4                   |                                     | 5                      | 0.52                          |       | 0.44  | 1     |                   | 0.36                           |       |      |    |
|                                   |                       | 0/10                  | 0.5                   |                                     | 10                     | 1.3                           |       | 1.1   | 2.6   |                   | 0.9                            |       |      |    |
|                                   |                       | 0/15                  | 1.5                   |                                     | 15                     | 3.6                           |       | 3.0   | 6.8   |                   | 2.4                            |       |      |    |
| I <sub>IH</sub> , I <sub>IL</sub> | Input leakage current | G, H types            | 0/18                  | Any input                           |                        | 18                            |       | ±0.1  |       | ±10 <sup>-5</sup> | ±0.1                           |       | ±1   | μA |
|                                   |                       | E, F types            | 0/15                  |                                     |                        | 15                            |       | ±0.3  |       | ±10 <sup>-5</sup> | ±0.3                           |       | ±1   |    |
| C <sub>I</sub>                    | Input capacitance     |                       | Any input             |                                     |                        |                               |       |       | 5     | 7.5               |                                |       | pF   |    |

\* T<sub>LOW</sub> = -55°C for G, H devices; -40°C for E, F devices.

\* T<sub>HIGH</sub> = +125°C for G, H devices; +85°C for E, F devices.

The Noise Margin for both "1" and "0" level is:

- 1 V min. with V<sub>DD</sub> = 5 V
- 2 V min. with V<sub>DD</sub> = 10 V
- 2.5 V min. with V<sub>DD</sub> = 15 V

**DYNAMIC ELECTRICAL CHARACTERISTICS**

( $T_A = 25^\circ\text{C}$ ,  $C_L = 50\text{ pF}$ ,  $R_L = 200\text{ kohm}$ , typical temperature coefficient for all  $V_{DD} = 0.3\%/^\circ\text{C}$  values, all input rise and fall times = 20 ns)

| PARAMETER                |                                  | TEST CONDITIONS<br>$V_{DD}(V)$ | VALUES    |      |      | UNIT          |
|--------------------------|----------------------------------|--------------------------------|-----------|------|------|---------------|
|                          |                                  |                                | min.      | typ. | max. |               |
| <b>Clocked operation</b> |                                  |                                |           |      |      |               |
| $t_{PLH}$                | Propagation delay time           | 5                              |           | 325  | 650  | ns            |
| $t_{PHL}$                | Decode out                       | 10                             |           | 135  | 270  |               |
|                          |                                  | 15                             |           | 85   | 170  |               |
|                          | Carry out                        | 5                              |           | 300  | 600  | ns            |
|                          |                                  | 10                             |           | 125  | 250  |               |
|                          |                                  | 15                             |           | 80   | 160  |               |
| $t_{THL}$                | Transition time                  | 5                              |           | 80   | 200  | ns            |
| $t_{TLH}$                | Carry Out or Decoded<br>Out Line | 10                             |           | 100  | 100  |               |
|                          |                                  | 15                             |           | 50   | 80   |               |
| $f_{CL}$                 | Minimum clock input frequency    | 5                              | 2.5       | 5    | 5    | MHz           |
|                          |                                  | 10                             | 5         | 10   |      |               |
|                          |                                  | 15                             | 5.5       | 11   |      |               |
| $t_w$                    | Maximum clock pulse width        | 5                              |           | 100  | 200  | ns            |
|                          |                                  | 10                             |           | 45   | 90   |               |
|                          |                                  | 15                             |           | 30   | 60   |               |
| $t_r$ $t_f$              | Clock input rise or fall time    | 5                              | Unlimited |      |      | $\mu\text{s}$ |
|                          |                                  | 10                             |           |      |      |               |
|                          |                                  | 15                             |           |      |      |               |
| $t_{\text{setup}}$       | Data setup time                  | 5                              |           | 115  | 230  | ns            |
|                          | Minimum clock inhibit            | 10                             |           | 50   | 100  |               |
|                          |                                  | 15                             |           | 35   | 75   |               |

**Reset operation**

|                  |                                  |    |  |     |     |    |
|------------------|----------------------------------|----|--|-----|-----|----|
| $t_{PLH}$        | Propagation delay time           | 5  |  | 265 | 530 | ns |
| $t_{PHL}$        | Carry Out or Decoded<br>Out Line | 10 |  | 115 | 230 |    |
|                  |                                  | 15 |  | 85  | 170 |    |
| $t_w$            | Minimum reset pulse width        | 5  |  | 130 | 260 | ns |
|                  |                                  | 10 |  | 55  | 110 |    |
|                  |                                  | 15 |  | 30  | 60  |    |
| $t_{\text{rem}}$ | Minimum reset removal time       | 5  |  | 200 | 400 | ns |
|                  |                                  | 10 |  | 140 | 280 |    |
|                  |                                  | 15 |  | 75  | 150 |    |

# PRESSETTABLE DIVIDE-BY-N COUNTER

## GENERAL DESCRIPTION

The MMC 4018 (G and H types) and MMC 4018 (E and F types) are monolithic integrated circuits, available in 16-lead dual in-line plastic or ceramic package, ceramic flat package and plastic micropackage.

The MMC 4018 types consists of 5 Johnson-Counter stages, buffered Q outputs from each stage, and counter preset control gating. CLOCK, RESET, DATA, PRESET ENABLE, and 5 individual JAM inputs are provided. Divide by 10, 8, 6, 4, or 2 counter configurations can be implemented by feeding the Q5, Q4, Q3, Q2, Q1 signals, respectively, back to the DATA input. Divide-by-9, 7, 5, or 3 counter configurations can be implemented by the use of a MMC 4014 gate package to properly gate the feedback connection to the DATA input. Divide-by-functions greater than 10 can be achieved by use of multiple

MMC 4018 units. The counter is advanced one count at the positive clock-signal transition. Schmitt-Trigger action on the clock line permits unlimited clock rise and fall times. A high RESET signal clears the counter to an all-zero condition. A high PRESET-ENABLE signal allows information on the JAM inputs to preset the counter. Anti-lock gating is provided to assure the proper counting sequence.

## FEATURES

- Medium speed operation 10 MHz (typ.) at  $V_{DD}-V_{SS} = 10$  V.
- Fully static operation.

## ABSOLUTE MAXIMUM RATINGS

|            |  |                    |              |          |
|------------|--|--------------------|--------------|----------|
| $V_{DD}^*$ | Supply voltage: G and H types<br>E and F types   | -0.5 to<br>-0.5 to | 20<br>18     | V<br>V   |
| $V_i$      | Input voltage  | -0.5 to            | $V_{DD}+0.5$ | V        |
| $I_i$      | DC input current (any one input)   |                    | $\pm 10$     | mA       |
| $P_{tot}$  | Total power dissipation (per package)<br>Dissipation per output transistor<br>for $T_A =$ full package-temperature range |                    | 200          | mW<br>mW |
| $T_A$      | Operating<br>temperature : G and H types<br>E and F types  | -55 to<br>-40 to   | 125<br>85    | °C<br>°C |
| $T_{stg}$  | Storage temperature  | -65 to             | 150          | °C       |

\* All voltage values are referred to  $V_{SS}$  pin voltage

## RECOMMENDED OPERATING CONDITIONS

|            |   |                  |           |          |
|------------|---|------------------|-----------|----------|
| $V_{DD}^*$ | Supply voltage: G and H types<br>E and F types            | 3 to<br>3 to     | 18<br>15  | V<br>V   |
| $V_i$      | Input voltage   | 0 to             | $V_{DD}$  | V        |
| $T_A$      | Operating<br>temperature : G and H types<br>E and F types | -55 to<br>-40 to | 125<br>85 | °C<br>°C |

## CONNECTION DIAGRAM

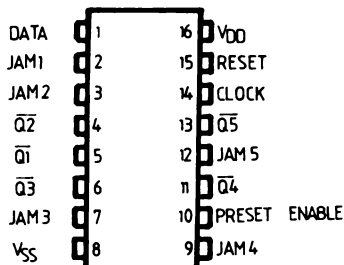

**LOGIC DIAGRAM**

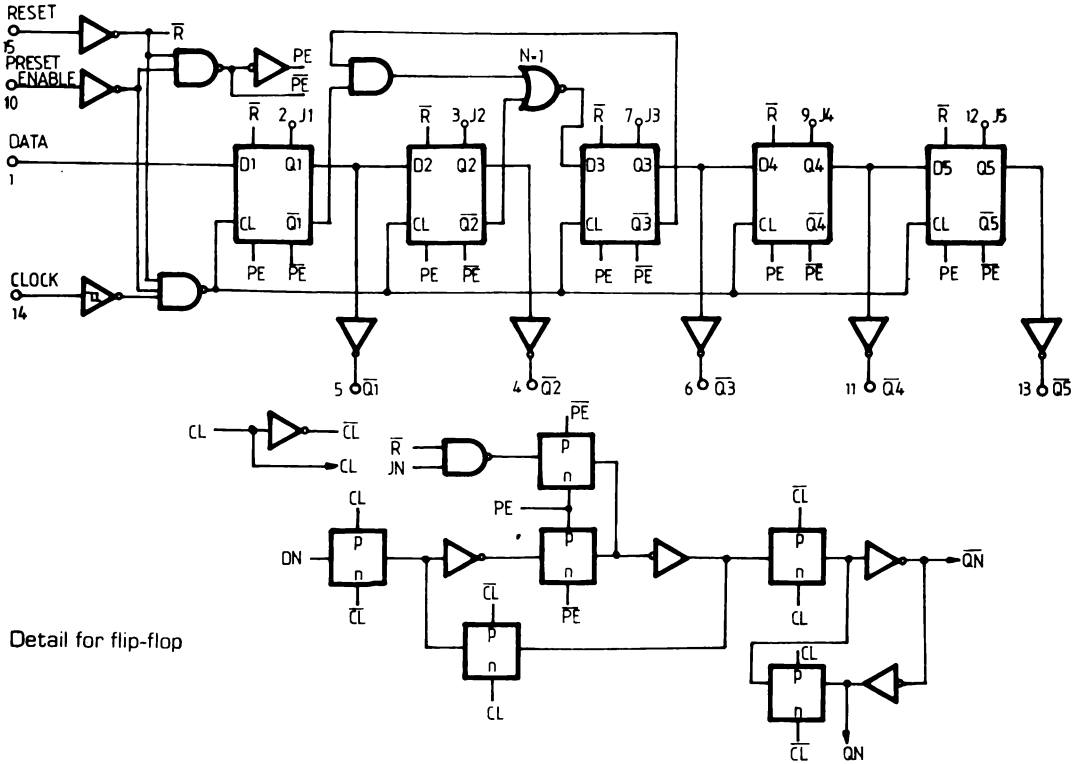

**TIMING DIAGRAM**

(Data input tied to  $\overline{Q5}$  for decade counter configuration)

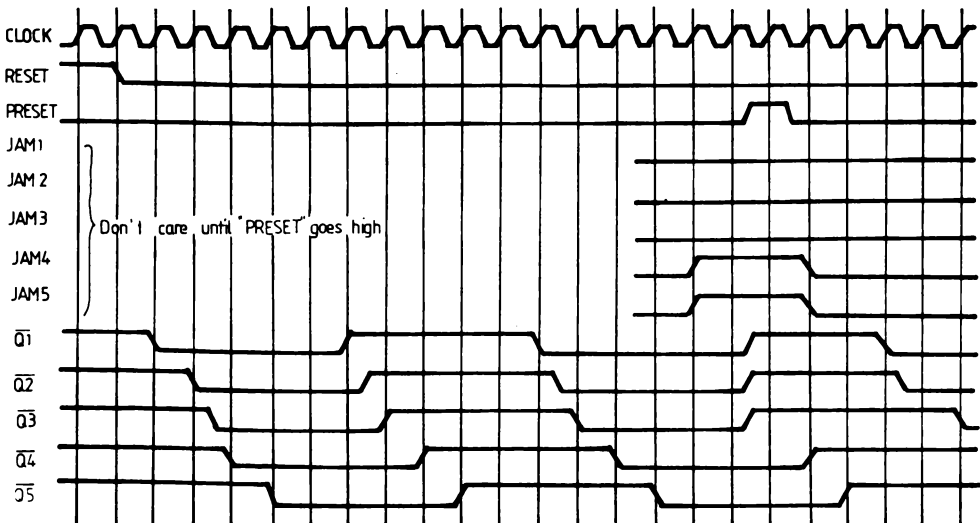



**STATIC ELECTRICAL CHARACTERISTICS**

(over recommended operating conditions)

| PARAMETER                         |                       | TEST CONDITIONS       |                       |                                |                        | VALUES             |       |           |       |                        |                     | UNIT  |         |
|-----------------------------------|-----------------------|-----------------------|-----------------------|--------------------------------|------------------------|--------------------|-------|-----------|-------|------------------------|---------------------|-------|---------|
|                                   |                       | V <sub>I</sub><br>(V) | V <sub>O</sub><br>(V) | I <sub>O</sub>  <br>( $\mu$ A) | V <sub>DD</sub><br>(V) | T <sub>LOW</sub> * |       | 25°C      |       |                        | T <sub>HIGH</sub> * |       |         |
|                                   |                       |                       |                       |                                |                        | min.               | max.  | min.      | typ   | max.                   | min.                |       | max.    |
| I <sub>L</sub>                    | Quiescent current     | G, H types            | 0/ 5                  |                                |                        | 5                  |       | 5         |       | 0.04                   | 5                   |       | 150     |
|                                   |                       |                       | 0/10                  |                                |                        | 10                 |       | 10        |       | 0.04                   | 10                  |       | 300     |
|                                   |                       |                       | 0/15                  |                                |                        | 15                 |       | 20        |       | 0.04                   | 20                  |       | 600     |
|                                   |                       |                       | 0/20                  |                                |                        | 20                 |       | 100       |       | 0.08                   | 100                 |       | 3000    |
|                                   |                       | E, F types            | 0/ 5                  |                                |                        | 5                  |       | 20        |       | 0.04                   | 20                  |       | 150     |
|                                   |                       |                       | 0/10                  |                                |                        | 10                 |       | 40        |       | 0.04                   | 40                  |       | 300     |
|                                   |                       |                       | 0/15                  |                                |                        | 15                 |       | 80        |       | 0.04                   | 80                  |       | 600     |
| V <sub>OH</sub>                   | Output high voltage   |                       | 0/ 5                  |                                | < 1                    | 5                  | 4.95  |           | 4.95  |                        |                     | 4.95  |         |
|                                   |                       |                       | 0/10                  |                                | < 1                    | 10                 | 9.95  |           | 9.95  |                        |                     | 9.95  |         |
|                                   |                       |                       | 0/15                  |                                | < 1                    | 15                 | 14.95 |           | 14.95 |                        |                     | 14.95 |         |
| V <sub>OL</sub>                   | Output low voltage    |                       | 5 /0                  |                                | < 1                    | 5                  |       |           |       |                        |                     | 0.05  |         |
|                                   |                       |                       | 10/0                  |                                | < 1                    | 10                 |       | 0.05      |       |                        |                     | 0.05  |         |
|                                   |                       |                       | 15/0                  |                                | < 1                    | 15                 |       | 0.05      |       |                        |                     | 0.05  |         |
| V <sub>IH</sub>                   | Input high voltage    |                       | 0.5/4.5               |                                | < 1                    | 5                  | 3.5   |           | 3.5   |                        |                     | 3.5   |         |
|                                   |                       |                       | 1/9                   |                                | < 1                    | 10                 | 7     |           | 7     |                        |                     | 7     |         |
|                                   |                       |                       | 1.5/13.5              |                                | < 1                    | 15                 | 11    |           | 11    |                        |                     | 11    |         |
| V <sub>IL</sub>                   | Input low voltage     |                       | 4.5/0.5               |                                | < 1                    | 5                  |       | 1.5       |       |                        | 1.5                 |       | 1.5     |
|                                   |                       |                       | 9/1                   |                                | < 1                    | 10                 |       | 3         |       |                        | 3                   |       | 3       |
|                                   |                       |                       | 13.5/1.5              |                                | < 1                    | 15                 |       | 4         |       |                        | 4                   |       | 4       |
| I <sub>OH</sub>                   | Output drive current  | G, H types            | 0/ 5                  | 2.5                            |                        | 5                  | -2    |           | -1.6  | -3.2                   |                     | -1.15 |         |
|                                   |                       |                       | 0/ 5                  | 4.6                            |                        | 5                  | -0.64 |           | -0.51 | -1                     |                     | -0.36 |         |
|                                   |                       |                       | 0/10                  | 9.5                            |                        | 10                 | -1.6  |           | -1.3  | -2.6                   |                     | -0.9  |         |
|                                   |                       |                       | 0/15                  | 13.5                           |                        | 15                 | -4.2  |           | -3.4  | -6.8                   |                     | -2.4  |         |
|                                   |                       | E, F types            | 0/ 5                  | 2.5                            |                        | 5                  | -1.53 |           | -1.36 | -3.2                   |                     | -1.1  |         |
|                                   |                       |                       | 0/ 5                  | 4.6                            |                        | 5                  | -0.52 |           | -0.44 | -1                     |                     | -0.36 |         |
|                                   |                       | 0/10                  | 9.5                   |                                | 10                     | -1.3               |       | -1.1      | -2.6  |                        | -0.9                |       |         |
|                                   |                       | 0/15                  | 13.5                  |                                | 15                     | -3.6               |       | -3.0      | -6.8  |                        | -2.4                |       |         |
| I <sub>OL</sub>                   | Output sink current   | G, H types            | 0/ 5                  | 0.4                            |                        | 5                  | 0.64  |           | 0.51  | 1                      |                     | 0.36  |         |
|                                   |                       |                       | 0/10                  | 0.5                            |                        | 10                 | 1.6   |           | 1.3   | 2.6                    |                     | 0.9   |         |
|                                   |                       |                       | 0/15                  | 1.5                            |                        | 15                 | 4.2   |           | 3.4   | 6.8                    |                     | 2.4   |         |
|                                   |                       | E, F types            | 0/ 5                  | 0.4                            |                        | 5                  | 0.52  |           | 0.44  | 1                      |                     | 0.36  |         |
|                                   |                       |                       | 0/10                  | 0.5                            |                        | 10                 | 1.3   |           | 1.1   | 2.6                    |                     | 0.9   |         |
|                                   |                       |                       | 0/15                  | 1.5                            |                        | 15                 | 3.6   |           | 3.0   | 6.8                    |                     | 2.4   |         |
| I <sub>IH</sub> , I <sub>IL</sub> | Input leakage current | G, H types            | 0/18                  | Any input                      |                        | 18                 |       | $\pm$ 0.1 |       | $\pm$ 10 <sup>-5</sup> | $\pm$ 0.1           |       | $\pm$ 1 |
|                                   |                       | E, F types            | 0/15                  |                                |                        | 15                 |       | $\pm$ 0.3 |       | $\pm$ 10 <sup>-5</sup> | $\pm$ 0.3           |       | $\pm$ 1 |
| C <sub>I</sub>                    | Input capacitance     |                       | Any input             |                                |                        |                    |       |           | 5     | 7.5                    |                     |       | pF      |

\* T<sub>LOW</sub> = -55°C for G, H devices; -40°C for E, F devices.

\* T<sub>HIGH</sub> = +125°C for G, H devices; +85°C for E, F devices.

The Noise Margin for both "1" and "0" level is:

- 1 V min. with V<sub>DD</sub> = 5 V
- 2 V min. with V<sub>DD</sub> = 10 V
- 2.5 V min. with V<sub>DD</sub> = 15 V

**DYNAMIC ELECTRICAL CHARACTERISTICS**

( $T_A = 25^\circ\text{C}$ ,  $C_L = 50\text{ pF}$ ,  $R_L = 200\text{ kohm}$ , typical temperature coefficient for all  $V_{DD}$  values is  $0.3\%/^\circ\text{C}$ , all input rise and fall times =  $20\text{ ns}$ ).

| PARAMETER                | TEST CONDITIONS<br>$V_{DD}$ (V) | VALUES    |      |      | UNIT          |
|--------------------------|---------------------------------|-----------|------|------|---------------|
|                          |                                 | min.      | typ. | max. |               |
| $t_{PLH}$ ,<br>$t_{PHL}$ | 5                               |           | 200  | 400  | ns            |
|                          | 10                              |           | 90   | 180  |               |
|                          | 15                              |           | 65   | 130  |               |
| $t_{THL}$ ,<br>$t_{TLH}$ | 5                               |           | 100  | 200  | ns            |
|                          | 10                              |           | 50   | 100  |               |
|                          | 15                              |           | 40   | 80   |               |
| $f_{CL}$                 | 5                               | 3         | 6    |      | MHz           |
|                          | 10                              | 7         | 14   |      |               |
|                          | 15                              | 8.5       | 17   |      |               |
| $t_w$                    | 5                               | 160       | 80   |      | ns            |
|                          | 10                              | 70        | 35   |      |               |
|                          | 15                              | 50        | 25   |      |               |
| $t_r$ , $t_f$            | 5                               | Unlimited |      |      | $\mu\text{s}$ |
|                          | 10                              |           |      |      |               |
|                          | 15                              |           |      |      |               |
| $t_{setup}$              | 5                               | 40        | 20   |      | ns            |
|                          | 10                              | 12        | 6    |      |               |
|                          | 15                              | 6         | 3    |      |               |
| $t_H$                    | 5                               | 140       | 70   |      | ns            |
|                          | 10                              | 80        | 40   |      |               |
|                          | 15                              | 60        | 30   |      |               |

**Preset\* or reset operation**

|                          |    |     |     |     |    |
|--------------------------|----|-----|-----|-----|----|
| $t_{PLH}$ ,<br>$t_{PHL}$ | 5  |     | 275 | 550 | ns |
|                          | 10 |     | 125 | 250 |    |
|                          | 15 |     | 90  | 180 |    |
| $t_w$                    | 5  | 160 | 80  |     | ns |
|                          | 10 | 70  | 35  |     |    |
|                          | 15 | 50  | 25  |     |    |
| $t_{rem}$                | 5  | 80  | 40  |     | ns |
|                          | 10 | 30  | 15  |     |    |
|                          | 15 | 20  | 10  |     |    |

\* At PRESET ENABLE OR JAM inputs.

# QUAD AND/OR SELECT GATE

## GENERAL DESCRIPTION

The MMC 4019 consists of four AND/OR select gate configurations, each consisting of two input AND gates driving a single 2-input OR gate. Selection is accomplished by control bits  $K_a$  and  $K_b$ . In addition to selection of either channel A or channel B information, the control bits can be applied simultaneously to accomplish the logical A + B function. The MMC 4019 E/F/G/H types are supplied in 16-lead hermetic dual-in-line ceramic or plastic package.

## FEATURES

- Medium-speed operation  $t_{PHL} = t_{PLH} = 60$  ns (TYP.) at  $V_{DD} = 10$  V,  $C_L = 50$  pF
- 100% tested for quiescent current

## APPLICATIONS

- AND-OR select gating
- Shift-right/shift/left registers
- True/complement selection
- And-OR/exclusive-OR selector

## ABSOLUTE MAXIMUM RATINGS

|            |  |                               |                            |                |
|------------|--|-------------------------------|----------------------------|----------------|
| $V_{DD}^*$ | Supply voltage: G and H types<br>E and F types   | -0.5 to<br>-0.5 to<br>-0.5 to | 20<br>18<br>$V_{DD} + 0.5$ | V<br>V<br>V    |
| $V_i$      | Input voltage  |                               |                            | V              |
| $I_i$      | DC input current (any one input)   |                               | $\pm 10$                   | mA             |
| $P_{tot}$  | Total power dissipation (per package)<br>Dissipation per output transistor<br>for $T_A =$ full package-temperature range |                               | 200                        | mW             |
| $T_A$      | Operating temperature : G and H types<br>E and F types   | -55 to<br>-40 to<br>-65 to    | 125<br>85<br>150           | °C<br>°C<br>°C |
| $T_{stg}$  | Storage temperature  |                               |                            | °C             |

\* All voltage values are referred to  $V_{SS}$  pin voltage

## RECOMMENDED OPERATING CONDITIONS

|            |  |                      |                      |             |
|------------|--|----------------------|----------------------|-------------|
| $V_{DD}^*$ | Supply voltage: G and H types<br>E and F types         | 3 to<br>3 to<br>0 to | 18<br>15<br>$V_{DD}$ | V<br>V<br>V |
| $V_i$      | Input voltage  |                      |                      | V           |
| $T_A$      | Operating temperature : G and H types<br>E and F types | -55 to<br>-40 to     | 125<br>85            | °C<br>°C    |

## CONNECTION DIAGRAM

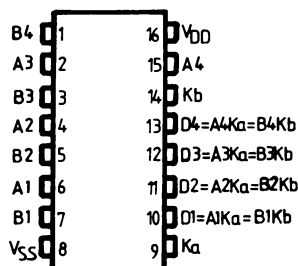

**STATIC ELECTRICAL CHARACTERISTICS**

(over recommended operating conditions)

| PARAMETER                         |                       | TEST CONDITIONS       |                       |                                |                        | VALUES             |       |           |       |                        |                     | UNIT  |         |
|-----------------------------------|-----------------------|-----------------------|-----------------------|--------------------------------|------------------------|--------------------|-------|-----------|-------|------------------------|---------------------|-------|---------|
|                                   |                       | V <sub>I</sub><br>(V) | V <sub>O</sub><br>(V) | I <sub>O</sub>  <br>( $\mu$ A) | V <sub>DD</sub><br>(V) | T <sub>LOW</sub> * |       | 25°C      |       |                        | T <sub>HIGH</sub> * |       |         |
|                                   |                       |                       |                       |                                |                        | min.               | max.  | min.      | typ   | max.                   | min.                |       | max.    |
| I <sub>L</sub>                    | Quiescent current     | G, H types            | 0/ 5                  |                                |                        | 5                  |       | 1         |       | 0.02                   | 1                   |       | 30      |
|                                   |                       |                       | 0/10                  |                                |                        | 10                 |       | 2         |       | 0.02                   | 2                   |       | 60      |
|                                   |                       |                       | 0/15                  |                                |                        | 15                 |       | 4         |       | 0.02                   | 4                   |       | 120     |
|                                   |                       |                       | 0/20                  |                                |                        | 20                 |       | 20        |       | 0.04                   | 20                  |       | 600     |
|                                   |                       | E, F types            | 0/ 5                  |                                |                        | 5                  |       | 4         |       | 0.02                   | 4                   |       | 30      |
|                                   |                       |                       | 0/10                  |                                |                        | 10                 |       | 8         |       | 0.02                   | 8                   |       | 60      |
|                                   |                       |                       | 0/15                  |                                |                        | 15                 |       | 16        |       | 0.02                   | 16                  |       | 120     |
| V <sub>OH</sub>                   | Output high voltage   |                       | 0/ 5                  |                                | < 1                    | 5                  | 4.95  |           | 4.95  |                        |                     | 4.95  |         |
|                                   |                       |                       | 0/10                  |                                | < 1                    | 10                 | 9.95  |           | 9.95  |                        |                     | 9.95  |         |
|                                   |                       |                       | 0/15                  |                                | < 1                    | 15                 | 14.95 |           | 14.95 |                        |                     | 14.95 |         |
| V <sub>OL</sub>                   | Output low voltage    |                       | 5 /0                  |                                | < 1                    | 5                  |       | 0.05      |       |                        |                     | 0.05  |         |
|                                   |                       |                       | 10/0                  |                                | < 1                    | 10                 |       | 0.05      |       |                        |                     | 0.05  |         |
|                                   |                       |                       | 15/0                  |                                | < 1                    | 15                 |       | 0.05      |       |                        |                     | 0.05  |         |
| V <sub>IH</sub>                   | Input high voltage    |                       |                       | 0.5/4.5                        | < 1                    | 5                  | 3.5   |           | 3.5   |                        |                     | 3.5   |         |
|                                   |                       |                       |                       | 1/9                            | < 1                    | 10                 | 7     |           | 7     |                        |                     | 7     |         |
|                                   |                       |                       |                       | 1.5/13.5                       | < 1                    | 15                 | 11    |           | 11    |                        |                     | 11    |         |
| V <sub>IL</sub>                   | Input low voltage     |                       |                       | 4.5/0.5                        | < 1                    | 5                  |       | 1.5       |       |                        | 1.5                 |       | 1.5     |
|                                   |                       |                       |                       | 9/1                            | < 1                    | 10                 |       | 3         |       |                        | 3                   |       | 3       |
|                                   |                       |                       |                       | 13.5/1.5                       | < 1                    | 15                 |       | 4         |       |                        | 4                   |       | 4       |
| I <sub>OH</sub>                   | Output drive current  | G, H types            | 0/ 5                  | 2.5                            |                        | 5                  | -2    |           | -1.6  | -3.2                   |                     | -1.15 |         |
|                                   |                       |                       | 0/ 5                  | 4.6                            |                        | 5                  | -0.64 |           | -0.51 | -1                     |                     | -0.36 |         |
|                                   |                       |                       | 0/10                  | 9.5                            |                        | 10                 | -1.6  |           | -1.3  | -2.6                   |                     | -0.9  |         |
|                                   |                       |                       | 0/15                  | 13.5                           |                        | 15                 | -4.2  |           | -3.4  | -6.8                   |                     | -2.4  |         |
|                                   |                       | E, F types            | 0/ 5                  | 2.5                            |                        | 5                  | -1.53 |           | -1.36 | -3.2                   |                     | -1.1  |         |
|                                   |                       |                       | 0/ 5                  | 4.6                            |                        | 5                  | -0.52 |           | -0.44 | -1                     |                     | -0.36 |         |
|                                   |                       |                       | 0/10                  | 9.5                            |                        | 10                 | -1.3  |           | -1.1  | -2.6                   |                     | -0.9  |         |
|                                   |                       |                       | 0/15                  | 13.5                           |                        | 15                 | -3.6  |           | -3.0  | -6.8                   |                     | -2.4  |         |
| I <sub>OL</sub>                   | Output sink current   | G, H types            | 0/ 5                  | 0.4                            |                        | 5                  | 0.64  |           | 0.51  | 1                      |                     | 0.36  |         |
|                                   |                       |                       | 0/10                  | 0.5                            |                        | 10                 | 1.6   |           | 1.3   | 2.6                    |                     | 0.9   |         |
|                                   |                       |                       | 0/15                  | 1.5                            |                        | 15                 | 4.2   |           | 3.4   | 6.8                    |                     | 2.4   |         |
|                                   |                       | E, F types            | 0/ 5                  | 0.4                            |                        | 5                  | 0.52  |           | 0.44  | 1                      |                     | 0.36  |         |
|                                   |                       |                       | 0/10                  | 0.5                            |                        | 10                 | 1.3   |           | 1.1   | 2.6                    |                     | 0.9   |         |
|                                   |                       |                       | 0/15                  | 1.5                            |                        | 15                 | 3.6   |           | 3.0   | 6.8                    |                     | 2.4   |         |
| I <sub>IH</sub> , I <sub>IL</sub> | Input leakage current | G, H types            | 0/18                  | Any input                      |                        | 18                 |       | $\pm$ 0.1 |       | $\pm$ 10 <sup>-5</sup> | $\pm$ 0.1           |       | $\pm$ 1 |
|                                   |                       | E, F types            | 0/15                  |                                |                        | 15                 |       | $\pm$ 0.3 |       | $\pm$ 10 <sup>-5</sup> | $\pm$ 0.3           |       | $\pm$ 1 |
| C <sub>I</sub>                    | Input capacitance     |                       |                       | Any input                      |                        |                    |       |           |       | 5                      | 7.5                 |       | $\mu$ F |

\* T<sub>LOW</sub> = -55°C for G, H devices; -40°C for E, F devices.

\* T<sub>HIGH</sub> = +125°C for G, H devices; +85°C for E, F devices.

The Noise Margin for both "1" and "0" level is:

- 1 V min. with V<sub>DD</sub> = 5 V
- 2 V min. with V<sub>DD</sub> = 10 V
- 2.5 V min. with V<sub>DD</sub> = 15 V

**DYNAMIC ELECTRICAL CHARACTERISTICS**

( $T_A = 25^\circ\text{C}$ ,  $C_L = 50\text{ pF}$ ,  $R_L = 200\text{ k}\Omega$ , typical temperature coefficient for all  $V_{DD}$  values is  $0.3\%/^\circ\text{C}$ , all input rise and fall times =  $20\text{ ns}$ )

| PARAMETER              | TEST CONDITIONS        | VALUES        |      |                 | UNIT              |      |
|------------------------|------------------------|---------------|------|-----------------|-------------------|------|
|                        |                        | $V_{DD}$ (V)  | min. | typ.            |                   | max. |
| $t_{PLH}$<br>$t_{PHL}$ | Propagation delay time | 5<br>10<br>15 |      | 150<br>60<br>50 | 300<br>120<br>100 | ns   |
| $t_{TLH}$<br>$t_{TLH}$ | Transition time        | 5<br>10<br>15 |      | 100<br>50<br>40 | 200<br>100<br>80  | ns   |

**TRUTH TABLE**

| $K_a$ | $K_b$ | $A_n$ | $B_n$ | DN |
|-------|-------|-------|-------|----|
| 1     | 0     | 1     | X     | 1  |
| 1     | 0     | 0     | X     | 0  |
| 0     | 1     | X     | 1     | 1  |
| 0     | 1     | X     | 0     | 0  |
| 1     | 1     | 0     | 0     | 0  |
| 1     | 1     | 0     | 1     | 1  |
| 1     | 1     | 1     | 0     | 1  |
| 1     | 1     | 1     | 1     | 1  |

X = Don't Care

**LOGIC DIAGRAM**

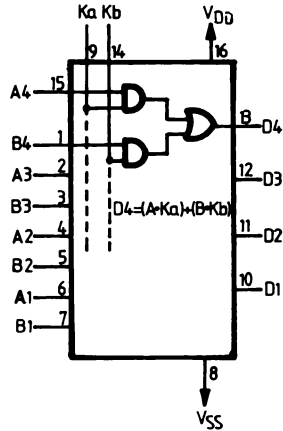

**TYPICAL APPLICATIONS**

SHIFT-LEFT SHIFT-RIGHT REGISTER

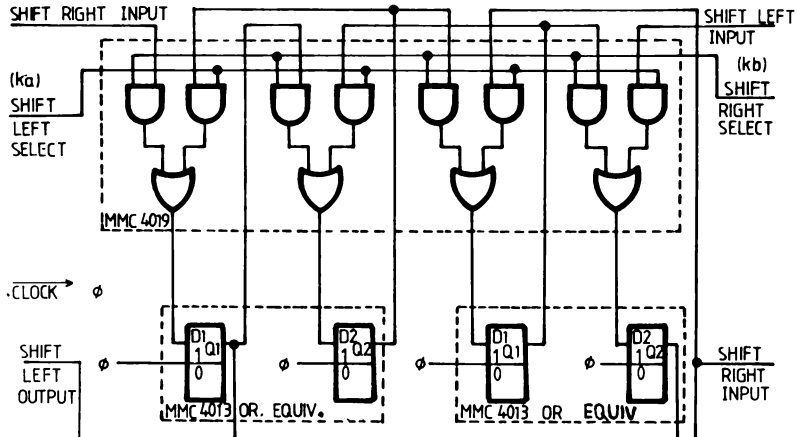

AND-OR SELECTED GATING

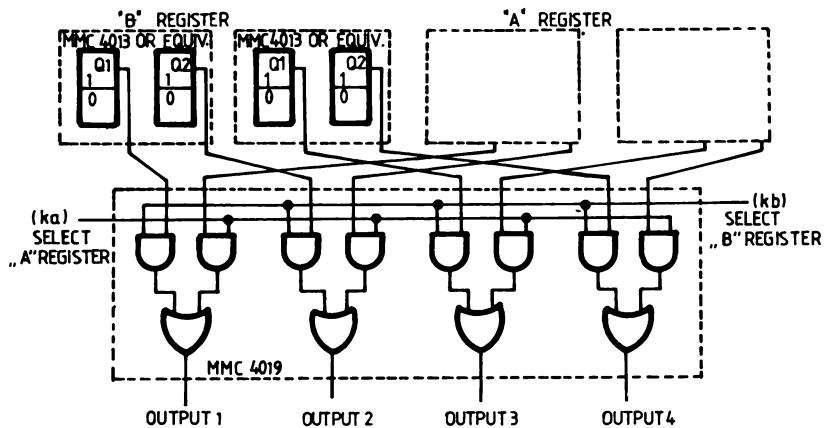

TRUE COMPLEMENT SELECTOR

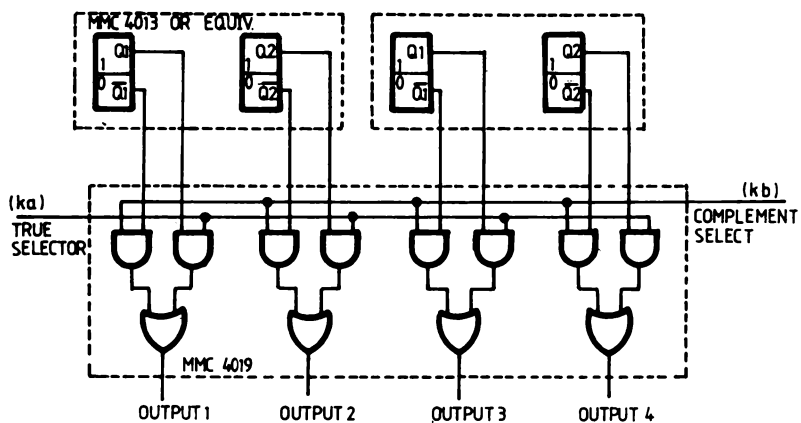

AND-OR exclusive OR selector

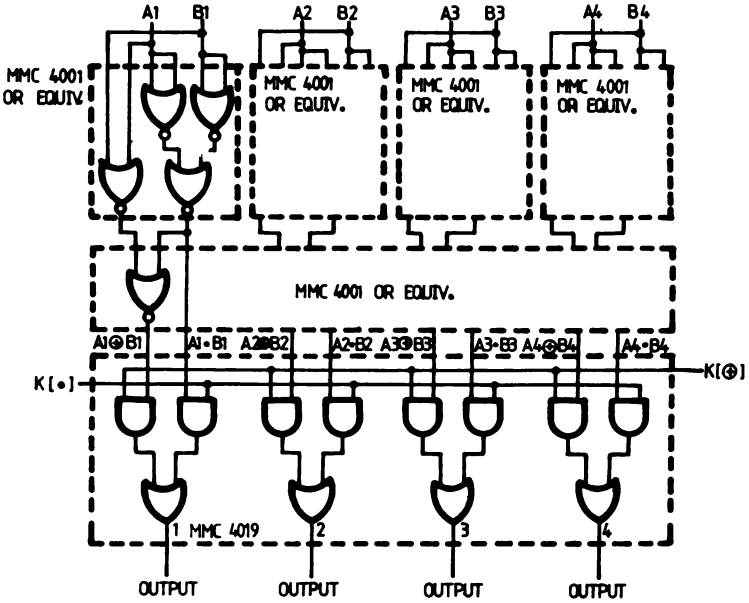

TRUTH TABLE

| $K(\cdot)$ | $K(\oplus)$ | OUT          |
|------------|-------------|--------------|
| 0          | 0           | 0            |
| 1          | 0           | $A - B$      |
| 0          | 1           | $A \oplus B$ |
| 1          | 1           | $A + B$      |

# RIPPLE-CARRY BINARY COUNTER/DIVIDERS:

**4020 - 14 STAGE**  
**4024 - 7 STAGE**  
**4040 - 12 STAGE**

## GENERAL DESCRIPTION

These devices are monolithic IC's fabricated with standard AL-gate CMOS technology. All counter stages are master-slave flip-flops.

The state of a counter advances one count on the negative transition of each input pulse. A high level on the RESET line resets the counter to its all zeros stage. Schmitt trigger action on the input-pulse line permits unlimited clock rise and fall times. All inputs and outputs are buffered. MMC 4020, MMC 4040 are available in 16-lead dual-in-line ceramic or plastic package and MMC 4024 is available in 14-lead dual-in-line plastic or ceramic package.

## FEATURES

- Medium-speed operation
- Fully static operation
- Buffered inputs and outputs
- Common RESET
- Quiescent current specified to 20 V
- Standardized symmetrical output characteristics
- 5 V, 10 V, and 15 V parametric ratings

## ABSOLUTE MAXIMUM RATINGS

|            |  |  |                  |                |
|------------|--|--|------------------|----------------|
| $V_{DD}^*$ | Supply voltage: G and H types<br>E and F types   | -0.5 to 20<br>-0.5 to 18<br>-0.5 to $V_{DD}+0.5$ | 20<br>18<br>V    | V              |
| $V_i$      | Input voltage  |  |                  | V              |
| $I_i$      | DC input current (any one input)   |  | $\pm 10$         | mA             |
| $P_{tot}$  | Total power dissipation (per package)<br>Dissipation per output transistor<br>for $T_A$ = full package-temperature range |  | 200              | mW             |
| $T_A$      | Operating temperature: G and H types<br>E and F types  | -55 to<br>-40 to<br>-65 to                       | 100<br>125<br>85 | mW<br>°C<br>°C |
| $T_{stg}$  | Storage temperature  |  | 150              | °C             |

\* All voltage values are referred to  $V_{SS}$  pin voltage

## RECOMMENDED OPERATING CONDITIONS

|            |   |                                     |               |          |
|------------|---|-------------------------------------|---------------|----------|
| $V_{DD}^*$ | Supply voltage: G and H types<br>E and F types        | 3 to 18<br>3 to 15<br>0 to $V_{DD}$ | 18<br>15<br>V | V        |
| $V_i$      | Input voltage   |                                     |               | V        |
| $T_A$      | Operating temperature: G and H types<br>E and F types | -55 to<br>-40 to                    | 125<br>85     | °C<br>°C |

## CONNECTION DIAGRAM

**MMC 4020**

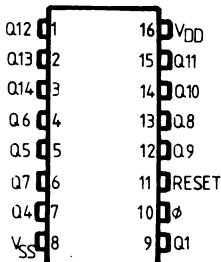

**MMC 4024**

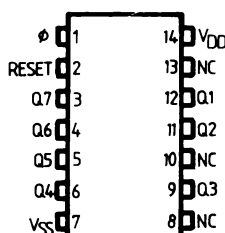

**MMC 4040**

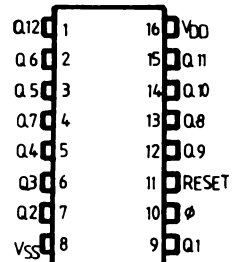



**LOGIC DIAGRAM**

**MMC 4020**

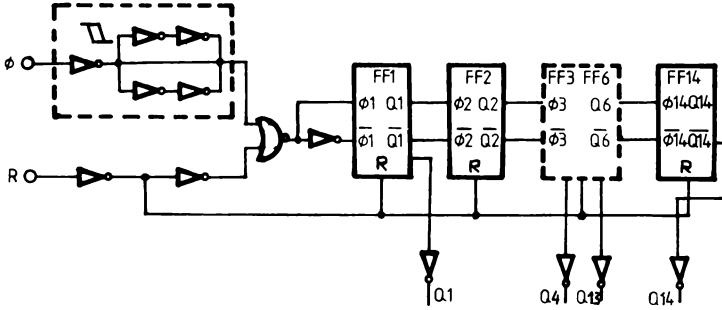

**MMC 4024**

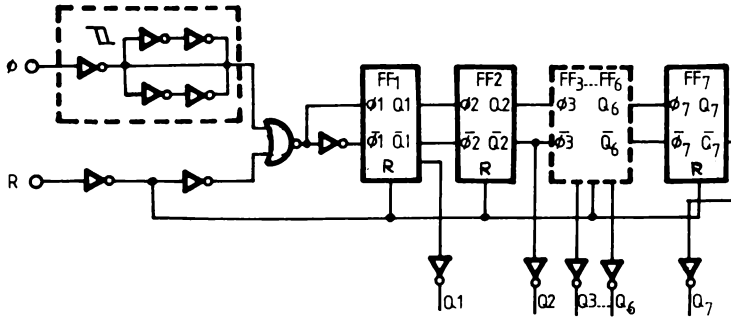

**MMC 4040**

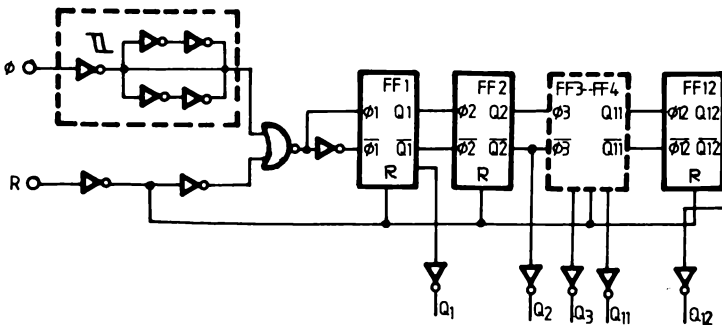

**STATIC ELECTRICAL CHARACTERISTICS**

(over recommended operating conditions)

| PARAMETER                       |                       |            | TEST CONDITIONS       |                            |                               |                        | VALUES               |                       |                |                        |                       |                     | UNIT    |      |
|---------------------------------|-----------------------|------------|-----------------------|----------------------------|-------------------------------|------------------------|----------------------|-----------------------|----------------|------------------------|-----------------------|---------------------|---------|------|
|                                 |                       |            | V <sub>I</sub><br>(V) | V <sub>O</sub><br>(V)      | I <sub>QI</sub><br>( $\mu$ A) | V <sub>DD</sub><br>(V) | T <sub>LOW</sub> *   |                       | 25°C           |                        |                       | T <sub>HIGH</sub> * |         |      |
|                                 |                       |            |                       |                            |                               |                        | min.                 | max.                  | min.           | typ                    | max.                  | min.                |         | max. |
| I <sub>L</sub>                  | Quiescent current     | G, H types | 0/ 5                  |                            |                               | 5                      |                      | 5                     |                | 0.04                   | 5                     |                     | 150     |      |
|                                 |                       |            | 0/10                  |                            |                               | 10                     |                      | 10                    |                | 0.04                   | 10                    |                     | 300     |      |
|                                 |                       |            | 0/15                  |                            |                               | 15                     |                      | 20                    |                | 0.04                   | 20                    |                     | 600     |      |
|                                 |                       |            | 0/20                  |                            |                               | 20                     |                      | 100                   |                | 0.08                   | 100                   |                     | 3000    |      |
|                                 | E, F types            | 0/ 5       |                       |                            | 5                             |                        | 20                   |                       | 0.04           | 20                     |                       | 150                 |         |      |
|                                 |                       | 0/10       |                       |                            | 10                            |                        | 40                   |                       | 0.04           | 40                     |                       | 300                 |         |      |
|                                 |                       | 0/15       |                       |                            | 15                            |                        | 80                   |                       | 0.04           | 80                     |                       | 600                 |         |      |
| V <sub>OH</sub>                 | Output high voltage   |            | 0/ 5<br>0/10<br>0/15  | < 1<br>< 1<br>< 1          | 5<br>10<br>15                 | 4.95<br>9.95<br>14.95  |                      | 4.95<br>9.95<br>14.95 |                |                        | 4.95<br>9.95<br>14.95 |                     | V       |      |
| V <sub>OL</sub>                 | Output low voltage    |            | 5 /0<br>10/0<br>15/0  | < 1<br>< 1<br>< 1          | 5<br>10<br>15                 |                        | 0.05<br>0.05<br>0.05 |                       |                |                        | 0.05<br>0.05<br>0.05  |                     | V       |      |
| V <sub>IH</sub>                 | Input high voltage    |            |                       | 0.5/4.5<br>1/9<br>1.5/13.5 | < 1<br>< 1<br>< 1             | 5<br>10<br>15          | 3.5<br>7<br>11       |                       | 3.5<br>7<br>11 |                        | 3.5<br>7<br>11        |                     | V       |      |
| V <sub>IL</sub>                 | Input low voltage     |            |                       | 4.5/0.5<br>9/1<br>13.5/1.5 | < 1<br>< 1<br>< 1             | 5<br>10<br>15          |                      | 1.5<br>3<br>4         |                |                        | 1.5<br>3<br>4         |                     | V       |      |
| I <sub>OH</sub>                 | Output drive current  | G, H types | 0/ 5                  | 2.5                        |                               | 5                      | -2                   |                       | -1.6           | -3.2                   |                       | -1.15               |         |      |
|                                 |                       |            | 0/ 5                  | 4.6                        |                               | 5                      | -0.64                |                       | -0.51          | -1                     |                       | -0.36               |         |      |
|                                 |                       |            | 0/10                  | 9.5                        |                               | 10                     | -1.6                 |                       | -1.3           | -2.6                   |                       | -0.9                |         |      |
|                                 |                       |            | 0/15                  | 13.5                       |                               | 15                     | -4.2                 |                       | -3.4           | -6.8                   |                       | -2.4                |         |      |
|                                 |                       | E, F types | 0/ 5                  | 2.5                        |                               | 5                      | -1.53                |                       | -1.36          | -3.2                   |                       | -1.1                |         |      |
|                                 |                       |            | 0/ 5                  | 4.6                        |                               | 5                      | -0.52                |                       | -0.44          | -1                     |                       | -0.36               |         |      |
|                                 |                       | 0/10       | 9.5                   |                            | 10                            | -1.3                   |                      | -1.1                  | -2.6           |                        | -0.9                  |                     |         |      |
|                                 |                       | 0/15       | 13.5                  |                            | 15                            | -3.6                   |                      | -3.0                  | -6.8           |                        | -2.4                  |                     |         |      |
| I <sub>OL</sub>                 | Output sink current   | G, H types | 0/ 5                  | 0.4                        |                               | 5                      | 0.64                 |                       | 0.51           | 1                      |                       | 0.36                |         |      |
|                                 |                       |            | 0/10                  | 0.5                        |                               | 10                     | 1.6                  |                       | 1.3            | 2.6                    |                       | 0.9                 |         |      |
|                                 |                       |            | 0/15                  | 1.5                        |                               | 15                     | 4.2                  |                       | 3.4            | 6.8                    |                       | 2.4                 |         |      |
|                                 |                       | E, F types | 0/ 5                  | 0.4                        |                               | 5                      | 0.52                 |                       | 0.44           | 1                      |                       | 0.36                |         |      |
|                                 |                       |            | 0/10                  | 0.5                        |                               | 10                     | 1.3                  |                       | 1.1            | 2.6                    |                       | 0.9                 |         |      |
|                                 |                       |            | 0/15                  | 1.5                        |                               | 15                     | 3.6                  |                       | 3.0            | 6.8                    |                       | 2.4                 |         |      |
| I <sub>IH</sub> I <sub>IL</sub> | Input leakage current | G, H types | 0/18                  | Any input                  |                               | 18                     |                      | $\pm$ 0.1             |                | $\pm$ 10 <sup>-5</sup> | $\pm$ 0.1             |                     | $\pm$ 1 |      |
|                                 |                       | E, F types | 0/15                  |                            |                               | 15                     |                      | $\pm$ 0.3             |                | $\pm$ 10 <sup>-5</sup> | $\pm$ 0.3             |                     | $\pm$ 1 |      |
| C <sub>I</sub>                  | Input capacitance     |            |                       | Any input                  |                               |                        |                      |                       |                | 5                      | 7.5                   |                     | pF      |      |

\* T<sub>LOW</sub> = -55°C for G, H devices; -40°C for E, F devices.

\* T<sub>HIGH</sub> = +125°C for G, H devices; +85°C for E, F devices.

The Noise Margin for both "1" and "0" level is:

- 1 V min. with V<sub>DD</sub> = 5 V
- 2 V min. with V<sub>DD</sub> = 10 V
- 2.5 V min. with V<sub>DD</sub> = 15 V

**DYNAMIC ELECTRICAL CHARACTERISTICS**

( $T_A \neq 25^\circ\text{C}$ ,  $C_L = 50\text{ pF}$ ,  $R_L = 200\text{ kohm}$ , typical temperature coefficient for all  $V_{DD} = 0.3\%/^\circ\text{C}$  values, all input rise and fall time = 20 ns)

| PARAMETER  | TEST CONDITIONS<br>$V_{DD}$ (V) | VALUES    |      |      | UNIT          |
|--|---------------------------------|-----------|------|------|---------------|
|  |                                 | min.      | typ. | max. |               |
| <b>Input pulse operation</b>                           |                                 |           |      |      |               |
| $t_{PLH}$ , Propagation delay time ( $\phi$ to Q1 Out) | 5                               |           | 180  | 360  | ns            |
| $t_{PHL}$  | 10                              |           | 80   | 160  |               |
|  | 15                              |           | 65   | 130  |               |
| $t_{PLH}$ , Propagation delay time $Q_n$ to $Q_{n+1}$  | 5                               |           | 100  | 200  | ns            |
| $t_{PHL}$  | 10                              |           | 40   | 80   |               |
|  | 15                              |           | 30   | 60   |               |
| $t_{TLH}$ , Transition time                            | 5                               |           | 100  | 200  | ns            |
| $t_{THL}$  | 10                              |           | 50   | 100  |               |
|  | 15                              |           | 40   | 80   |               |
| $t_W$ , Minimum input pulse width                      | 5                               |           | 70   | 140  | ns            |
|  | 10                              |           | 30   | 60   |               |
|  | 15                              |           | 20   | 40   |               |
| $t_r, t_f$ , Input rise and fall time                  | 5                               | Unlimited |      |      | $\mu\text{s}$ |
|  | 10                              |           |      |      |               |
|  | 15                              |           |      |      |               |
| $f_{max}$ , Maximum input clock frequency              | 5                               | 3.5       | 7    |      | MHz           |
|  | 10                              | 8         | 16   |      |               |
|  | 15                              | 12        | 24   |      |               |

**Reset operation**

|                                    |    |  |     |     |    |
|------------------------------------|----|--|-----|-----|----|
| $t_{PHL}$ , Propagation delay time | 5  |  | 140 | 280 | ns |
|                                    | 10 |  | 60  | 120 |    |
|                                    | 15 |  | 50  | 100 |    |
| $t_W$ , Minimum reset pulse width  | 5  |  | 100 | 200 | ns |
|                                    | 10 |  | 40  | 80  |    |
|                                    | 15 |  | 30  | 60  |    |
| $t_{rem}$ , Reset removal time     | 5  |  | 175 | 350 | ns |
|                                    | 10 |  | 75  | 150 |    |
|                                    | 15 |  | 50  | 100 |    |

Detail of flip-flop stage

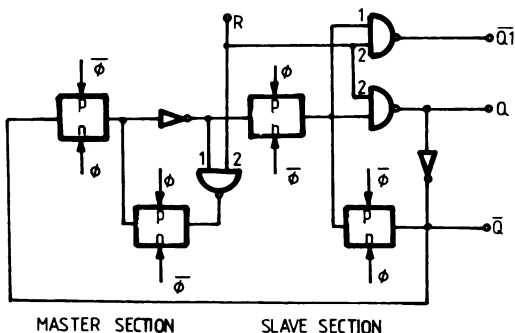

# DUAL J-K MASTER SLAVE FLIP-FLOP

## GENERAL DESCRIPTION

The MMC 4027 is a monolithic integrated circuit, available in 16-lead dual in-line plastic or ceramic package.

The MMC 4027 is a single monolithic chip integrated circuit containing two identical complementary-symmetry J-K master-slave flip-flops. Each flip-flop has provisions for individual J, K, Set, Reset and Clock input signals. Buffered Q and Q signals are provided as outputs. This input-output arrangement provides for compatible operation with the MMC 4013 dual D-type flip-flop.

The MMC 4027 is useful in performing control, register, and toggle functions. Logic levels present at the J and K inputs along with internal self-steering control the state of each flip-flop; changes in the flip-flop state are synchronous with the positive-going transition of the clock pulse. Set and reset functions are independent of the clock and are initiated when a high level signal is present at either the Set or Reset input.

## FEATURES

- Set-Reset capability
- Static flip-flop operation-retains state indefinitely with clock level either „high“ or „low“
- Medium speed operation-16 MHz (typ.) clock toggle rate at 10 V
- 100% tested for quiescent current

## APPLICATIONS

- Registers, counters, control circuits

## ABSOLUTE MAXIMUM RATINGS

|            |  |  |                        |
|------------|--|--|------------------------|
| $V_{DD}^*$ | Supply voltage: G and H types<br>E and F types   | -0.5 to 20<br>-0.5 to 18<br>-0.5 to $V_{DD}+0.5$ | V<br>V<br>V            |
| $V_i$      | Input voltage  |  |                        |
| $I_i$      | DC input current (any one input)   | $\pm 10$   | mA                     |
| $P_{tot}$  | Total power dissipation (per package)<br>Dissipation per output transistor<br>for $T_A$ = full package-temperature range |  | 200<br>100<br>mW       |
| $T_A$      | Operating temperature : G and H types<br>E and F types   | -55 to -40 to -65 to                             | 125 85 150<br>°C °C °C |
| $T_{stg}$  | Storage temperature  |  | 150 °C                 |

\* All voltage values are referred to  $V_{SS}$  pin voltage

## RECOMMENDED OPERATING CONDITIONS

|            |  |                |                         |
|------------|--|----------------|-------------------------|
| $V_{DD}^*$ | Supply voltage: G and H types<br>E and F types         | 3 to 3 to 0 to | 18 15 $V_{DD}$<br>V V V |
| $V_i$      | Input voltage  |                |                         |
| $T_A$      | Operating temperature : G and H types<br>E and F types | -55 to -40 to  | 125 85<br>°C °C         |

## CONNECTION DIAGRAM

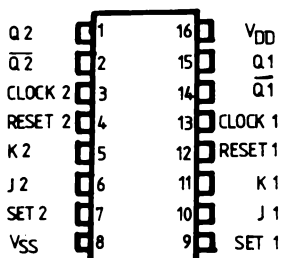

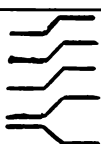
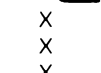
| PRESENT STATE |   |   |   |   | CL <sup>●</sup>   | NEXT STATE OUTPUTS |   |
|---------------|---|---|---|---|---|--------------------|---|
| J             | K | S | R | Q |   | Q                  | Q |
| 1             | X | 0 | 0 | 0 |  | 1                  | 0 |
| X             | 0 | 0 | 0 | 1 |   | 1                  | 0 |
| 0             | X | 0 | 0 | 0 |   | 0                  | 1 |
| X             | 1 | 0 | 0 | 1 |   | 0                  | 1 |
| X             | X | 0 | 0 | X |  | -                  | - |
| X             | X | 1 | 0 | X |   | 1                  | 0 |
| X             | X | 0 | 1 | X |   | 0                  | 1 |
| X             | X | 1 | 1 | X |   | 1                  | 1 |
| -NO CHANGE    |   |   |   |   |   |                    |   |

**STATIC ELECTRICAL CHARACTERISTICS**

(over recommended operating conditions)

| PARAMETER                         |                       | TEST CONDITIONS       |                       |                                |                        | VALUES             |       |           |       |               |                     | UNIT  |         |
|-----------------------------------|-----------------------|-----------------------|-----------------------|--------------------------------|------------------------|--------------------|-------|-----------|-------|---------------|---------------------|-------|---------|
|                                   |                       | V <sub>I</sub><br>(V) | V <sub>O</sub><br>(V) | I <sub>O</sub>  <br>( $\mu$ A) | V <sub>DD</sub><br>(V) | T <sub>LOW</sub> * |       | 25°C      |       |               | T <sub>HIGH</sub> * |       |         |
|                                   |                       |                       |                       |                                |                        | min.               | max.  | min.      | typ   | max.          | min.                |       | max.    |
| I <sub>L</sub>                    | Quiescent current     | G, H types            | 0/ 5                  |                                |                        | 5                  |       | 1         |       | 0.02          | 1                   |       | 30      |
|                                   |                       |                       | 0/10                  |                                |                        | 10                 |       | 2         |       | 0.02          | 2                   |       | 60      |
|                                   |                       |                       | 0/15                  |                                |                        | 15                 |       | 4         |       | 0.02          | 4                   |       | 120     |
|                                   |                       |                       | 0/20                  |                                |                        | 20                 |       | 20        |       | 0.04          | 20                  |       | 600     |
|                                   | E, F types            | 0/ 5                  |                       |                                | 5                      |                    | 4     |           | 0.02  | 4             |                     | 30    |         |
|                                   |                       | 0/10                  |                       |                                | 10                     |                    | 8     |           | 0.02  | 8             |                     | 60    |         |
| 0/15                              |                       |                       |                       | 15                             |                        | 16                 |       | 0.02      | 16    |               | 120                 |       |         |
| V <sub>OH</sub>                   | Output high voltage   | 0/ 5                  |                       | < 1                            | 5                      | 4.95               |       | 4.95      |       |               | 4.95                |       | V       |
|                                   |                       | 0/10                  |                       | < 1                            | 10                     | 9.95               |       | 9.95      |       |               | 9.95                |       |         |
|                                   |                       | 0/15                  |                       | < 1                            | 15                     | 14.95              |       | 14.95     |       |               | 14.95               |       |         |
| V <sub>OL</sub>                   | Output low voltage    | 5 /0                  |                       | < 1                            | 5                      |                    | 0.05  |           |       | 0.05          |                     | 0.05  | V       |
|                                   |                       | 10/0                  |                       | < 1                            | 10                     |                    | 0.05  |           |       | 0.05          |                     | 0.05  |         |
|                                   |                       | 15/0                  |                       | < 1                            | 15                     |                    | 0.05  |           |       | 0.05          |                     | 0.05  |         |
| V <sub>IH</sub>                   | Input high voltage    |                       | 0.5/4.5               | < 1                            | 5                      | 3.5                |       | 3.5       |       |               | 3.5                 |       | V       |
|                                   |                       |                       | 1/9                   | < 1                            | 10                     | 7                  |       | 7         |       |               | 7                   |       |         |
|                                   |                       |                       | 1.5/13.5              | < 1                            | 15                     | 11                 |       | 11        |       |               | 11                  |       |         |
| V <sub>IL</sub>                   | Input low voltage     |                       | 4.5/0.5               | < 1                            | 5                      |                    | 1.5   |           |       | 1.5           |                     | 1.5   | V       |
|                                   |                       |                       | 9/1                   | < 1                            | 10                     |                    | 3     |           |       | 3             |                     | 3     |         |
|                                   |                       |                       | 13.5/1.5              | < 1                            | 15                     |                    | 4     |           |       | 4             |                     | 4     |         |
| I <sub>OH</sub>                   | Output drive current  | G, H types            | 0/ 5                  | 2.5                            |                        | 5                  | -2    |           | -1.6  | -3.2          |                     | -1.15 | mA      |
|                                   |                       |                       | 0/ 5                  | 4.6                            |                        | 5                  | -0.64 |           | -0.51 | -1            |                     | -0.36 |         |
|                                   |                       |                       | 0/10                  | 9.5                            |                        | 10                 | -1.6  |           | -1.3  | -2.6          |                     | -0.9  |         |
|                                   |                       |                       | 0/15                  | 13.5                           |                        | 15                 | -4.2  |           | -3.4  | -6.8          |                     | -2.4  |         |
|                                   | E, F types            | 0/ 5                  | 2.5                   |                                | 5                      | -1.53              |       | -1.36     | -3.2  |               | -1.1                |       |         |
|                                   |                       | 0/ 5                  | 4.6                   |                                | 5                      | -0.52              |       | -0.44     | -1    |               | -0.36               |       |         |
| 0/10                              |                       | 9.5                   |                       | 10                             | -1.3                   |                    | -1.1  | -2.6      |       | -0.9          |                     |       |         |
|                                   | 0/15                  | 13.5                  |                       | 15                             | -3.6                   |                    | -3.0  | -6.8      |       | -2.4          |                     |       |         |
| I <sub>OL</sub>                   | Output sink current   | G, H types            | 0/ 5                  | 0.4                            |                        | 5                  | 0.64  |           | 0.51  | 1             |                     | 0.36  | mA      |
|                                   |                       |                       | 0/10                  | 0.5                            |                        | 10                 | 1.6   |           | 1.3   | 2.6           |                     | 0.9   |         |
|                                   |                       |                       | 0/15                  | 1.5                            |                        | 15                 | 4.2   |           | 3.4   | 6.8           |                     | 2.4   |         |
|                                   | E, F types            | 0/ 5                  | 0.4                   |                                | 5                      | 0.52               |       | 0.44      | 1     |               | 0.36                |       |         |
|                                   |                       | 0/10                  | 0.5                   |                                | 10                     | 1.3                |       | 1.1       | 2.6   |               | 0.9                 |       |         |
|                                   |                       | 0/15                  | 1.5                   |                                | 15                     | 3.6                |       | 3.0       | 6.8   |               | 2.4                 |       |         |
| I <sub>IH</sub> , I <sub>IL</sub> | Input leakage current | G, H types            | 0/18                  | Any input                      |                        | 18                 |       | $\pm 0.1$ |       | $\pm 10^{-5}$ | $\pm 0.1$           |       | $\pm 1$ |
|                                   |                       | E, F types            | 0/15                  |                                |                        | 15                 |       | $\pm 0.3$ |       | $\pm 10^{-5}$ | $\pm 0.3$           |       | $\pm 1$ |
| C <sub>I</sub>                    | Input capacitance     |                       | Any input             |                                |                        |                    |       |           | 5     | 7.5           |                     |       | pF      |

\* T<sub>LOW</sub> = -55°C for G, H devices; -40°C for E, F devices.

\* T<sub>HIGH</sub> = +125°C for G, H devices; +85°C for E, F devices.

The Noise Margin for both "1" and "0" level is:

- 1 V min. with V<sub>DD</sub> = 5 V
- 2 V min. with V<sub>DD</sub> = 10 V
- 2.5 V min. with V<sub>DD</sub> = 15 V

**DYNAMIC ELECTRICAL CHARACTERISTICS**

( $T_A = 25^\circ\text{C}$ ,  $C_L = 50\text{ pF}$ ,  $R_L = 200\text{ k}\Omega$ , typical temperature coefficient for all  $V_{DD}$  values is  $0.3\%/^\circ\text{C}$ , all input rise and fall times =  $20\text{ ns}$ )

| PARAMETER              |                                |                                | TEST CONDITIONS    | VALUES |      |      | UNIT |
|------------------------|--------------------------------|--------------------------------|--------------------|--------|------|------|------|
|                        |                                |                                | $V_{DD}(\text{V})$ | Min.   | Typ. | Max. |      |
| $t_{PLH}$<br>$t_{PHL}$ | Propagation delay time         | Clock to or Q outputs          | 5                  |        | 150  | 300  | ns   |
|                        |                                |                                | 10                 |        | 65   | 130  |      |
|                        |                                |                                | 15                 |        | 45   | 190  |      |
| $t_{PLH}$              | Propagation delay time         | Set to Q or Reset to $\bar{Q}$ | 5                  |        | 150  | 300  | ns   |
|                        |                                |                                | 10                 |        | 65   | 130  |      |
|                        |                                |                                | 15                 |        | 45   | 90   |      |
| $t_{PHL}$              | Propagation delay time         | Set to $\bar{Q}$ or Reset to Q | 5                  |        | 200  | 400  | ns   |
|                        |                                |                                | 10                 |        | 85   | 170  |      |
|                        |                                |                                | 15                 |        | 60   | 120  |      |
| $t_{THL}$<br>$t_{TLH}$ | Transition time                |                                | 5                  |        | 100  | 200  | ns   |
|                        |                                |                                | 10                 |        | 50   | 100  |      |
|                        |                                |                                | 15                 |        | 40   | 80   |      |
| $t_W$                  | Pulse width                    | Clock                          | 5                  | 140    | 70   |      | ns   |
|                        |                                |                                | 10                 | 60     | 30   |      |      |
|                        |                                |                                | 15                 | 40     | 20   |      |      |
| $t_W$                  | Pulse width                    | Set or Reset                   | 5                  | 180    | 90   |      | ns   |
|                        |                                |                                | 10                 | 80     | 40   |      |      |
|                        |                                |                                | 15                 | 50     | 25   |      |      |
| $t_{r,r}$<br>$t_f$     | Clock input rise or fall time  |                                | 5                  |        |      | 15   | ns   |
|                        |                                |                                | 10                 |        |      | 4    |      |
|                        |                                |                                | 15                 |        |      | 1    |      |
| $t_{setup}$            | Setup time                     | Data                           | 5                  | 200    | 100  |      | ns   |
|                        |                                |                                | 10                 | 75     | 35   |      |      |
|                        |                                |                                | 15                 | 50     | 25   |      |      |
| $f_{max}$              | Maximum clock input frequency* | Toggle mode                    | 5                  | 3.5    | 7    |      | MHz  |
|                        |                                |                                | 10                 | 8      | 16   |      |      |
|                        |                                |                                | 15                 | 12     | 24   |      |      |

\* Input  $t_r$ ,  $t_f = 5\text{ ns}$ .

**LOGIC DIAGRAM**

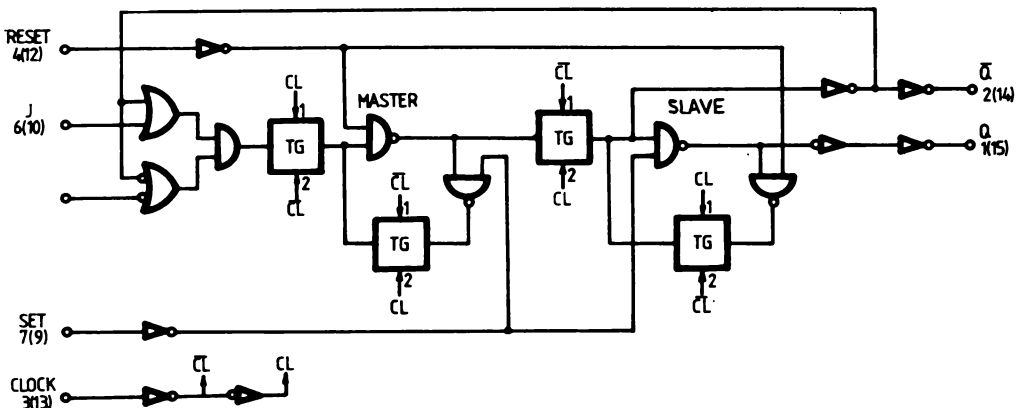

# BCD-TO-DECIMAL DECODER

## GENERAL DESCRIPTION

The MMC 4028 is a BCD-to-decimal or binary-to-octal decoder. This device is a monolithic IC fabricated in standard Al-gate CMOS technology. MMC 4028 is available in 16-lead dual in line ceramic and plastic package. The MMC 4028 consists of buffering on all four inputs decoding-logic gates, and 10 output buffers. A BCD code applied to the four inputs, A to D, results in a high level at the selected one of ten decimal decoded outputs. High drive capability is provided at all outputs to enhance dc and dynamic performance in high fan-out applications.

## FEATURES

- High decoded output drive capability
- Medium speed operation
- „Positive logic“ inputs and outputs (decoded outputs go high on selection)

## ABSOLUTE MAXIMUM RATINGS

|            |  |                                |                            |                  |                |
|------------|--|--------------------------------|----------------------------|------------------|----------------|
| $V_{DD}^*$ | Supply voltage: G and H types<br>E and F types   | -0.5 to<br>-0.5 to<br>-0.5 to  | 20<br>18<br>$V_{DD} + 0.5$ | V<br>V<br>V      |                |
| $V_i$      | Input voltage  |                                |                            |                  |                |
| $I_i$      | DC input current (any one input)   |                                | $\pm 10$                   | mA               |                |
| $P_{tot}$  | Total power dissipation (per package)<br>Dissipation per output transistor<br>for $T_A =$ full package-temperature range |                                | 200                        | mW               |                |
| $T_A$      | Operating<br>temperature :   | G and H types<br>E and F types | -55 to<br>-40 to<br>-65 to | 125<br>85<br>150 | °C<br>°C<br>°C |
| $T_{stg}$  | Storage temperature  |                                |                            |                  |                |

\* All voltage values are referred to  $V_{SS}$  pin voltage

## RECOMMENDED OPERATING CONDITIONS

|            |  |                                |                      |             |          |
|------------|--|--------------------------------|----------------------|-------------|----------|
| $V_{DD}^*$ | Supply voltage: G and H types<br>E and F types | 3 to<br>3 to<br>0 to           | 18<br>15<br>$V_{DD}$ | V<br>V<br>V |          |
| $V_i$      | Input voltage                                  |                                |                      |             |          |
| $T_A$      | Operating<br>temperature :                     | G and H types<br>E and F types | -55 to<br>-40 to     | 125<br>85   | °C<br>°C |

## CONNECTION DIAGRAM

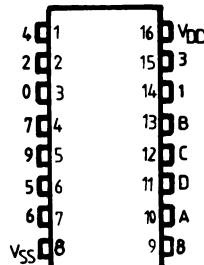

**STATIC ELECTRICAL CHARACTERISTICS**

(over recommended operating conditions)

| PARAMETER                       |                       | TEST CONDITIONS       |                       |                               |                        | VALUES             |       |           |       |                        |                     | UNIT  |         |         |  |
|---------------------------------|-----------------------|-----------------------|-----------------------|-------------------------------|------------------------|--------------------|-------|-----------|-------|------------------------|---------------------|-------|---------|---------|--|
|                                 |                       | V <sub>I</sub><br>(V) | V <sub>O</sub><br>(V) | I <sub>O1</sub><br>( $\mu$ A) | V <sub>DD</sub><br>(V) | T <sub>LOW</sub> * |       | 25°C      |       |                        | T <sub>HIGH</sub> * |       |         |         |  |
|                                 |                       |                       |                       |                               |                        | min.               | max.  | min.      | typ   | max.                   | min.                |       | max.    |         |  |
| I <sub>L</sub>                  | Quiescent current     | G, H types            | 0/ 5                  |                               |                        | 5                  |       | 5         |       | 0.04                   | 5                   |       | 150     |         |  |
|                                 |                       |                       | 0/10                  |                               |                        | 10                 |       | 10        |       | 0.04                   | 10                  |       | 300     |         |  |
|                                 |                       |                       | 0/15                  |                               |                        | 15                 |       | 20        |       | 0.04                   | 20                  |       | 600     |         |  |
|                                 |                       |                       | 0/20                  |                               |                        | 20                 |       | 100       |       | 0.08                   | 100                 |       | 3000    |         |  |
|                                 | E, F types            | 0/ 5                  |                       |                               | 5                      |                    | 20    |           | 0.04  | 20                     |                     | 150   |         |         |  |
|                                 |                       | 0/10                  |                       |                               | 10                     |                    | 40    |           | 0.04  | 40                     |                     | 300   |         |         |  |
|                                 | 0/15                  |                       |                       | 15                            |                        | 80                 |       | 0.04      | 80    |                        | 600                 |       |         |         |  |
| V <sub>OH</sub>                 | Output high voltage   | 0/ 5                  |                       | < 1                           | 5                      | 4.95               |       | 4.95      |       |                        | 4.95                |       | V       |         |  |
|                                 |                       | 0/10                  |                       | < 1                           | 10                     | 9.95               |       | 9.95      |       |                        | 9.95                |       |         |         |  |
|                                 |                       | 0/15                  |                       | < 1                           | 15                     | 14.95              |       | 14.95     |       |                        | 14.95               |       |         |         |  |
| V <sub>OL</sub>                 | Output low voltage    | 5 /0                  |                       | < 1                           | 5                      |                    | 0.05  |           |       | 0.05                   |                     | 0.05  | V       |         |  |
|                                 |                       | 10/0                  |                       | < 1                           | 10                     |                    | 0.05  |           |       | 0.05                   |                     | 0.05  |         |         |  |
|                                 |                       | 15/0                  |                       | < 1                           | 15                     |                    | 0.05  |           |       | 0.05                   |                     | 0.05  |         |         |  |
| V <sub>IH</sub>                 | Input high voltage    |                       | 0.5/4.5               | < 1                           | 5                      | 3.5                |       | 3.5       |       |                        | 3.5                 |       | V       |         |  |
|                                 |                       |                       | 1/9                   | < 1                           | 10                     | 7                  |       | 7         |       |                        | 7                   |       |         |         |  |
|                                 |                       |                       | 1.5/13.5              | < 1                           | 15                     | 11                 |       | 11        |       |                        | 11                  |       |         |         |  |
| V <sub>IL</sub>                 | Input low voltage     |                       | 4.5/0.5               | < 1                           | 5                      |                    | 1.5   |           |       | 1.5                    |                     | 1.5   | V       |         |  |
|                                 |                       |                       | 9/1                   | < 1                           | 10                     |                    | 3     |           |       | 3                      |                     | 3     |         |         |  |
|                                 |                       |                       | 13.5/1.5              | < 1                           | 15                     |                    | 4     |           |       | 4                      |                     | 4     |         |         |  |
| I <sub>OH</sub>                 | Output drive current  | G, H types            | 0/ 5                  | 2.5                           |                        | 5                  | -2    |           | -1.6  | -3.2                   |                     | -1.15 |         | mA      |  |
|                                 |                       |                       | 0/ 5                  | 4.6                           |                        | 5                  | -0.64 |           | -0.51 | -1                     |                     | -0.36 |         |         |  |
|                                 |                       |                       | 0/10                  | 9.5                           |                        | 10                 | -1.6  |           | -1.3  | -2.6                   |                     | -0.9  |         |         |  |
|                                 |                       |                       | 0/15                  | 13.5                          |                        | 15                 | -4.2  |           | -3.4  | -6.8                   |                     | -2.4  |         |         |  |
|                                 |                       | E, F types            | 0/ 5                  | 2.5                           |                        | 5                  | -1.53 |           | -1.36 | -3.2                   |                     | -1.1  |         |         |  |
|                                 |                       |                       | 0/ 5                  | 4.6                           |                        | 5                  | -0.52 |           | -0.44 | -1                     |                     | -0.36 |         |         |  |
|                                 |                       | 0/10                  | 9.5                   |                               | 10                     | -1.3               |       | -1.1      | -2.6  |                        | -0.9                |       |         |         |  |
|                                 |                       | 0/15                  | 13.5                  |                               | 15                     | -3.6               |       | -3.0      | -6.8  |                        | -2.4                |       |         |         |  |
| I <sub>OL</sub>                 | Output sink current   | G, H types            | 0/ 5                  | 0.4                           |                        | 5                  | 0.64  |           | 0.51  | 1                      |                     | 0.36  |         | mA      |  |
|                                 |                       |                       | 0/10                  | 0.5                           |                        | 10                 | 1.6   |           | 1.3   | 2.6                    |                     | 0.9   |         |         |  |
|                                 |                       |                       | 0/15                  | 1.5                           |                        | 15                 | 4.2   |           | 3.4   | 6.8                    |                     | 2.4   |         |         |  |
|                                 |                       | E, F types            | 0/ 5                  | 0.4                           |                        | 5                  | 0.52  |           | 0.44  | 1                      |                     | 0.36  |         |         |  |
|                                 |                       |                       | 0/10                  | 0.5                           |                        | 10                 | 1.3   |           | 1.1   | 2.6                    |                     | 0.9   |         |         |  |
|                                 |                       |                       | 0/15                  | 1.5                           |                        | 15                 | 3.6   |           | 3.0   | 6.8                    |                     | 2.4   |         |         |  |
| I <sub>IH</sub> I <sub>IL</sub> | Input leakage current | G, H types            | 0/18                  | Any input                     |                        | 18                 |       | $\pm$ 0.1 |       | $\pm$ 10 <sup>-5</sup> | $\pm$ 0.1           |       | $\pm$ 1 | $\mu$ A |  |
|                                 |                       | E, F types            | 0/15                  |                               |                        | 15                 |       | $\pm$ 0.3 |       | $\pm$ 10 <sup>-5</sup> | $\pm$ 0.3           |       | $\pm$ 1 |         |  |
| C <sub>I</sub>                  | Input capacitance     |                       | Any input             |                               |                        |                    |       |           | 5     | 7.5                    |                     |       | pF      |         |  |

\* T<sub>LOW</sub> = -55°C for G, H devices; -40°C for E, F devices.

\* T<sub>HIGH</sub> = +125°C for G, H devices; +85°C for E, F devices.

The Noise Margin for both "1" and "0" level is:

- 1 V min. with V<sub>DD</sub> = 5 V
- 2 V min. with V<sub>DD</sub> = 10 V
- 2.5 V min. with V<sub>DD</sub> = 15 V



**DYNAMIC ELECTRICAL CHARACTERISTICS**

( $T_A = 25^\circ\text{C}$ ,  $C_L = 50\text{ pF}$ ,  $R_L = 200\text{ K}$ , typical temperature coefficient for all  $V_{DD}$  values is  $0.3\text{ \%}/^\circ\text{C}$  all input rise and fall times =  $20\text{ ns}$ )

| PARAMETER  | TEST CONDITIONS<br>$V_{DD}$ (V) | VALUES |      |      | UM |
|--|---------------------------------|--------|------|------|----|
|  |                                 | min.   | typ. | max. |    |
| $t_{PHL}$<br>Propagation delay time (clock to out) | 5                               |        | 175  | 350  | ns |
|  | 10                              |        | 80   | 160  |    |
|  | 15                              |        | 60   | 120  |    |
| $t_{THL}$<br>$t_{TLH}$ Transition time             | 5                               |        | 100  | 200  | ns |
|  | 10                              |        | 50   | 100  |    |
|  | 15                              |        | 40   | 80   |    |

**LOGIC DIAGRAM**

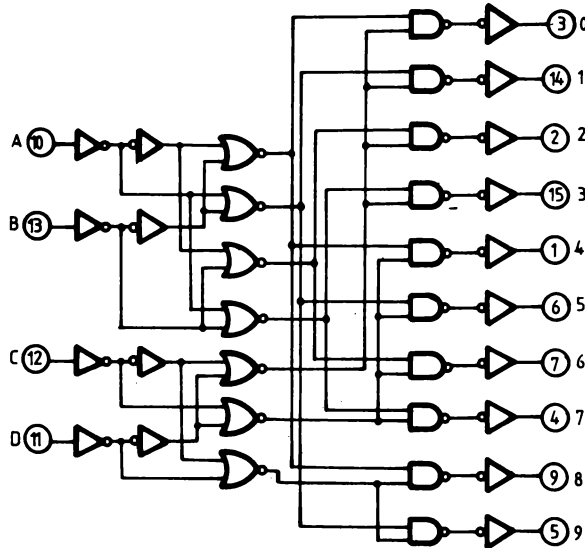

**TRUTH TABLE**

| D | C | B | A | 0 | 1 | 2 | 3 | 4 | 5 | 6 | 7 | 8 | 9 |
|---|---|---|---|---|---|---|---|---|---|---|---|---|---|
| 0 | 0 | 0 | 0 | 1 | 0 | 0 | 0 | 0 | 0 | 0 | 0 | 0 | 0 |
| 0 | 0 | 0 | 1 | 0 | 1 | 0 | 0 | 0 | 0 | 0 | 0 | 0 | 0 |
| 0 | 0 | 1 | 0 | 0 | 0 | 1 | 0 | 0 | 0 | 0 | 0 | 0 | 0 |
| 0 | 0 | 1 | 1 | 0 | 0 | 0 | 0 | 1 | 0 | 0 | 0 | 0 | 0 |
| 0 | 1 | 0 | 0 | 0 | 0 | 0 | 0 | 0 | 1 | 0 | 0 | 0 | 0 |
| 0 | 1 | 0 | 1 | 0 | 0 | 0 | 0 | 0 | 0 | 1 | 0 | 0 | 0 |
| 0 | 1 | 1 | 0 | 0 | 0 | 0 | 0 | 0 | 0 | 0 | 1 | 0 | 0 |
| 0 | 1 | 1 | 1 | 0 | 0 | 0 | 0 | 0 | 0 | 0 | 0 | 1 | 0 |
| 1 | 0 | 0 | 0 | 0 | 0 | 0 | 0 | 0 | 0 | 0 | 0 | 0 | 1 |
| 1 | 0 | 0 | 1 | 0 | 0 | 0 | 0 | 0 | 0 | 0 | 0 | 0 | 0 |
| 1 | 0 | 1 | 0 | 0 | 0 | 0 | 0 | 0 | 0 | 0 | 0 | 0 | 0 |
| 1 | 0 | 1 | 1 | 0 | 0 | 0 | 0 | 0 | 0 | 0 | 0 | 0 | 0 |
| 1 | 1 | 0 | 0 | 0 | 0 | 0 | 0 | 0 | 0 | 0 | 0 | 0 | 0 |
| 1 | 1 | 0 | 1 | 0 | 0 | 0 | 0 | 0 | 0 | 0 | 0 | 0 | 0 |
| 1 | 1 | 1 | 0 | 0 | 0 | 0 | 0 | 0 | 0 | 0 | 0 | 0 | 0 |
| 1 | 1 | 1 | 1 | 0 | 0 | 0 | 0 | 0 | 0 | 0 | 0 | 0 | 0 |
| 1 | 1 | 1 | 1 | 0 | 0 | 0 | 0 | 0 | 0 | 0 | 0 | 0 | 0 |

WHERE 1 = HIGH LEVEL  
0 = LOW LEVEL

# PRESETTABLE UP/DOWN COUNTER BINARY OR BCD-DECADE

## GENERAL DESCRIPTION

The MMC 4029 is a monolithic integrated circuit, available in 16-lead dual in-line plastic or ceramic package.

The MMC 4029 consists of a four-stage binary or BCD-decade up/down counter with provisions for look-ahead carry in both counting modes. The inputs consist of a single CLOCK,  $\overline{\text{CARRY-IN}}$  ( $\overline{\text{CLOCK}}$

$\overline{\text{ENABLE}}$ ), BINARY/DECADE, UP/DOWN, PRESET

ENABLE signals. Q1, Q2, Q3, Q4 and a  $\overline{\text{CARRY OUT}}$  signal are provided as outputs. A high PRESET ENABLE signal allows information on the JAM INPUTS to preset the counter to any state asynchronously with the clock. A low on each JAM line, when the PRESET-ENABLE signal is high, resets the counter to its zero count. The counter is advanced one count at the positive transition of the clock when the  $\overline{\text{CARRY-IN}}$  or PRESET ENABLE signals are high.

Advancement is inhibited when the  $\overline{\text{CARRY-IN}}$  or PRESET ENABLE signals are high. The  $\overline{\text{CARRY-OUT}}$  signal is normally high and goes low when the counter reaches its maximum count in the UP mode or the minimum count in the DOWN mode provided

the  $\overline{\text{CARRY-IN}}$  signal is low. The  $\overline{\text{CARRY-IN}}$  signal in the low state can thus be considered a  $\overline{\text{CLOCK}}$

ENABLE. The  $\overline{\text{CARRY-IN}}$  terminal must be connected to  $V_{SS}$  when not in use. Binary counting is accomplished when the BINARY/DECADE input is high; the counter counts in the decade mode when the BINARY/DECADE input is low.

Multiple packages can be connected in either a parallel-clocking or a ripple-clocking arrangement as shown in cascading counter packages. Parallel clocking provides synchronous control and hence faster response from all counting outputs. Ripple-clocking allows for longer clock input rise and fall times.

## FEATURES

- Medium speed operation—8 MHz (typ.) at  $C_L = 50$  pF and  $V_{DD}-V_{SS} = 10$  V
- Multi-package parallel clocking for synchronous high speed output response or ripple clocking for slow clock input rise and fall times
- "PRESET ENABLE" and individual "JAM" inputs provided
- Binary or decade up/down counting
- BCD outputs in decade mode

## ABSOLUTE MAXIMUM RATINGS

|            |  |         |                |    |
|------------|--|---------|----------------|----|
| $V_{DD}^*$ | Supply voltage: G and H types  | -0.5 to | 20             | V  |
|            | E and F types  | -0.5 to | 18             | V  |
| $V_i$      | Input voltage  | -0.5 to | $V_{DD} + 0.5$ | V  |
| $I_i$      | DC input current (any one input)   |         | $\pm 10$       | mA |
| $P_{tot}$  | Total power dissipation (per package)  |         | 200            | mW |
|            | Dissipation per output transistor for $T_A =$ full package-temperature range |         | 100            | mW |
| $T_A$      | Operating temperature :  |         |                |    |
|            | G and H types  | -55 to  | 125            | °C |
|            | E and F types  | -40 to  | 85             | °C |
| $T_{stg}$  | Storage temperature  | -65 to  | 150            | °C |

\* All voltage values are referred to  $V_{SS}$  pin voltage

## RECOMMENDED OPERATING CONDITIONS

|            |                               |        |          |    |
|------------|-------------------------------|--------|----------|----|
| $V_{DD}^*$ | Supply voltage: G and H types | 3 to   | 18       | V  |
|            | E and F types                 | 3 to   | 15       | V  |
| $V_i$      | Input voltage                 | 0 to   | $V_{DD}$ | V  |
| $T_A$      | Operating temperature :       |        |          |    |
|            | G and H types                 | -55 to | 125      | °C |
|            | E and F types                 | -40 to | 85       | °C |

## CONNECTION DIAGRAM

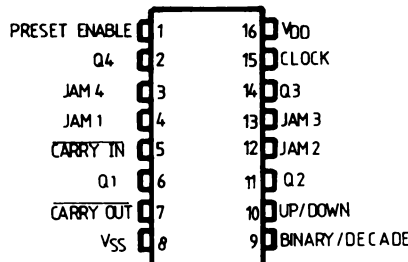

**STATIC ELECTRICAL CHARACTERISTICS**

(over recommended operating conditions)

| PARAMETER                       |                       | TEST CONDITIONS       |                       |                                 |                        | VALUES             |       |           |       |                        |                     | UNIT  |         |
|---------------------------------|-----------------------|-----------------------|-----------------------|---------------------------------|------------------------|--------------------|-------|-----------|-------|------------------------|---------------------|-------|---------|
|                                 |                       | V <sub>I</sub><br>(V) | V <sub>O</sub><br>(V) | I <sub>oI</sub>  <br>( $\mu$ A) | V <sub>DD</sub><br>(V) | T <sub>LOW</sub> * |       | 25°C      |       |                        | T <sub>HIGH</sub> * |       |         |
|                                 |                       |                       |                       |                                 |                        | min.               | max.  | min.      | typ   | max.                   | min.                |       | max.    |
| I <sub>L</sub>                  | Quiescent current     | G, H types            | 0/ 5                  |                                 |                        | 5                  |       | 5         |       | 0.04                   | 5                   |       | 150     |
|                                 |                       |                       | 0/10                  |                                 |                        | 10                 |       | 10        |       | 0.04                   | 10                  |       | 300     |
|                                 |                       |                       | 0/15                  |                                 |                        | 15                 |       | 20        |       | 0.04                   | 20                  |       | 600     |
|                                 |                       |                       | 0/20                  |                                 |                        | 20                 |       | 100       |       | 0.08                   | 100                 |       | 3000    |
|                                 |                       | E, F types            | 0/ 5                  |                                 |                        | 5                  |       | 20        |       | 0.04                   | 20                  |       | 150     |
|                                 |                       |                       | 0/10                  |                                 |                        | 10                 |       | 40        |       | 0.04                   | 40                  |       | 300     |
|                                 |                       |                       | 0/15                  |                                 |                        | 15                 |       | 80        |       | 0.04                   | 80                  |       | 600     |
| V <sub>OH</sub>                 | Output high voltage   |                       | 0/ 5                  |                                 | < 1                    | 5                  | 4.95  |           | 4.95  |                        | 4.95                |       |         |
|                                 |                       |                       | 0/10                  |                                 | < 1                    | 10                 | 9.95  |           | 9.95  |                        | 9.95                |       |         |
|                                 |                       |                       | 0/15                  |                                 | < 1                    | 15                 | 14.95 |           | 14.95 |                        | 14.95               |       |         |
| V <sub>OL</sub>                 | Output low voltage    |                       | 5 /0                  |                                 | < 1                    | 5                  |       | 0.05      |       |                        | 0.05                |       | 0.05    |
|                                 |                       |                       | 10/0                  |                                 | < 1                    | 10                 |       | 0.05      |       |                        | 0.05                |       | 0.05    |
|                                 |                       |                       | 15/0                  |                                 | < 1                    | 15                 |       | 0.05      |       |                        | 0.05                |       | 0.05    |
| V <sub>IH</sub>                 | Input high voltage    |                       | 0.5/4.5               | < 1                             | 5                      | 3.5                |       | 3.5       |       |                        | 3.5                 |       |         |
|                                 |                       |                       | 1/9                   | < 1                             | 10                     | 7                  |       | 7         |       |                        | 7                   |       |         |
|                                 |                       |                       | 1.5/13.5              | < 1                             | 15                     | 11                 |       | 11        |       |                        | 11                  |       |         |
| V <sub>IL</sub>                 | Input low voltage     |                       | 4.5/0.5               | < 1                             | 5                      |                    | 1.5   |           |       | 1.5                    |                     | 1.5   |         |
|                                 |                       |                       | 9/1                   | < 1                             | 10                     |                    | 3     |           |       | 3                      |                     | 3     |         |
|                                 |                       |                       | 13.5/1.5              | < 1                             | 15                     |                    | 4     |           |       | 4                      |                     | 4     |         |
| I <sub>OH</sub>                 | Output drive current  | G, H types            | 0/ 5                  | 2.5                             |                        | 5                  | -2    |           | -1.6  | -3.2                   |                     | -1.15 |         |
|                                 |                       |                       | 0/ 5                  | 4.6                             |                        | 5                  | -0.64 |           | -0.51 | -1                     |                     | -0.36 |         |
|                                 |                       |                       | 0/10                  | 9.5                             |                        | 10                 | -1.6  |           | -1.3  | -2.6                   |                     | -0.9  |         |
|                                 |                       |                       | 0/15                  | 13.5                            |                        | 15                 | -4.2  |           | -3.4  | -6.8                   |                     | -2.4  |         |
|                                 |                       | E, F types            | 0/ 5                  | 2.5                             |                        | 5                  | -1.53 |           | -1.36 | -3.2                   |                     | -1.1  |         |
|                                 |                       |                       | 0/ 5                  | 4.6                             |                        | 5                  | -0.52 |           | -0.44 | -1                     |                     | -0.36 |         |
|                                 |                       |                       | 0/10                  | 9.5                             |                        | 10                 | -1.3  |           | -1.1  | -2.6                   |                     | -0.9  |         |
|                                 |                       |                       | 0/15                  | 13.5                            |                        | 15                 | -3.6  |           | -3.0  | -6.8                   |                     | -2.4  |         |
| I <sub>OL</sub>                 | Output sink current   | G, H types            | 0/ 5                  | 0.4                             |                        | 5                  | 0.64  |           | 0.51  | 1                      |                     | 0.36  |         |
|                                 |                       |                       | 0/10                  | 0.5                             |                        | 10                 | 1.6   |           | 1.3   | 2.6                    |                     | 0.9   |         |
|                                 |                       |                       | 0/15                  | 1.5                             |                        | 15                 | 4.2   |           | 3.4   | 6.8                    |                     | 2.4   |         |
|                                 |                       | E, F types            | 0/ 5                  | 0.4                             |                        | 5                  | 0.52  |           | 0.44  | 1                      |                     | 0.36  |         |
|                                 |                       |                       | 0/10                  | 0.5                             |                        | 10                 | 1.3   |           | 1.1   | 2.6                    |                     | 0.9   |         |
|                                 |                       |                       | 0/15                  | 1.5                             |                        | 15                 | 3.6   |           | 3.0   | 6.8                    |                     | 2.4   |         |
| I <sub>IH</sub> I <sub>IL</sub> | Input leakage current | G, H types            | 0/18                  | Any input                       |                        | 18                 |       | $\pm$ 0.1 |       | $\pm$ 10 <sup>-5</sup> | $\pm$ 0.1           |       | $\pm$ 1 |
|                                 |                       | E, F types            | 0/15                  |                                 |                        | 15                 |       | $\pm$ 0.3 |       | $\pm$ 10 <sup>-5</sup> | $\pm$ 0.3           |       | $\pm$ 1 |
| C <sub>I</sub>                  | Input capacitance     |                       |                       | Any input                       |                        |                    |       |           | 5     | 7.5                    |                     |       | pF      |

\* T<sub>LOW</sub> = -55°C for G, H devices; -40°C for E, F devices.

\* T<sub>HIGH</sub> = +125°C for G, H devices; +85°C for E, F devices.

The Noise Margin for both "1" and "0" level is:

- 1 V min. with V<sub>DD</sub> = 5 V
- 2 V min. with V<sub>DD</sub> = 10 V
- 2.5 V min. with V<sub>DD</sub> = 15 V

**DYNAMIC ELECTRICAL CHARACTERISTICS**

( $T_A = 25^\circ\text{C}$ ,  $C_L = 50\text{ pF}$ ,  $R_L = 200\text{ k}\Omega$ , typical temperature coefficient for all  $V_{DD} = 0.3\%/^\circ\text{C}$ , all input rise and fall times = 20 ns)

| PARAMETER   | TEST CONDITIONS<br>$V_{DD}$ (V) | VALUES |      |      | UNIT          |
|---|---------------------------------|--------|------|------|---------------|
|   |                                 | min.   | typ. | max. |               |
| <b>Clocked operation</b>                                  |                                 |        |      |      |               |
| $t_{PLH}$ , Propagation delay time (Q outputs)            | 5                               |        | 250  | 500  | ns            |
| $t_{PHL}$   | 10                              |        | 120  | 240  |               |
|   | 15                              |        | 90   | 180  |               |
| $t_{PLH}$ , Propagation delay time (Carry Output)         | 5                               |        | 280  | 560  | ns            |
| $t_{THL}$   | 10                              |        | 130  | 260  |               |
|   | 15                              |        | 95   | 190  |               |
| $t_{TLH}$ , Transition time (Q outputs, carry output)     | 5                               |        | 100  | 200  | ns            |
| $t_{THL}$   | 10                              |        | 50   | 100  |               |
|   | 15                              |        | 40   | 80   |               |
| $t_W$ , Minimum clock pulse width                         | 5                               |        | 90   | 180  | ns            |
|   | 10                              |        | 45   | 90   |               |
|   | 15                              |        | 30   | 60   |               |
| $t_r$ , $t_f$ ** Clock rise and fall time                 | 5                               |        |      | 15   | $\mu\text{s}$ |
|   | 10                              |        |      | 15   |               |
|   | 15                              |        |      | 15   |               |
| $t_{\text{setup}}$ ***Minimum setup time (Carry input)    | 5                               |        | 30   | 60   | ns            |
|   | 10                              |        | 10   | 20   |               |
|   | 15                              |        | 6    | 12   |               |
| $t_{\text{setup}}$ Minimum setup time (B/D or U/D)        | 5                               |        | 170  | 340  | ns            |
|   | 10                              |        | 70   | 140  |               |
|   | 15                              |        | 50   | 100  |               |
| $f_{\text{max}}$ Maximum clock input frequency            | 5                               | 2      | 4    |      | MHz           |
|   | 10                              | 2      | 8    |      |               |
|   | 15                              | 5.5    | 11   |      |               |
| <b>Preset enable</b>                                      |                                 |        |      |      |               |
| $t_{THL}$ , Propagation delay time (Q outputs)            | 5                               |        | 235  | 470  | ns            |
| $t_{TLH}$   | 10                              |        | 100  | 200  |               |
|   | 15                              |        | 80   | 160  |               |
| $t_{PHL}$ , Propagation delay time (Carry Output)         | 5                               |        | 320  | 640  | ns            |
| $t_{PLH}$   | 10                              |        | 145  | 290  |               |
|   | 15                              |        | 105  | 210  |               |
| $t_W$ , Minimum Preset enable (pulse width)               | 5                               |        | 65   | 130  | ns            |
|   | 10                              |        | 35   | 70   |               |
|   | 15                              |        | 25   | 50   |               |
| $t_{\text{rem}}$ *** Minimum preset enable (removal time) | 5                               |        | 100  | 200  | ns            |
|   | 10                              |        | 55   | 110  |               |
|   | 15                              |        | 40   | 80   |               |
| <b>Carry input</b>  |                                 |        |      |      |               |
| $t_{PHL}$ , Propagation delay time (Carry output)         | 5                               |        | 170  | 340  | ns            |
| $t_{PLH}$   | 10                              |        | 70   | 140  |               |
|   | 15                              |        | 50   | 100  |               |
| $t_{\text{setup}}$ *** Minimum setup time (Carry input)   | 5                               |        | 25   | 50   | ns            |
|   | 10                              |        | 15   | 30   |               |
|   | 15                              |        | 12   | 25   |               |

| PARAMETER   | TEST CONDITIONS<br>$V_{DD}$ (V) | VALUES |                 |                 | UNIT |
|---|---------------------------------|--------|-----------------|-----------------|------|
|   |                                 | min.   | typ.            | max.            |      |
| $t_{hold}$ ***<br>Minimum hold time (Carry input) | 5<br>10<br>15                   |        | 100<br>35<br>30 | 200<br>70<br>60 | ns   |

- \* If more than one unit is cascaded in the parallel clocked application,  $t_r$  should be made less than or equal to the sum of the fixed propagation delay at 15 pF and the transition time of the carry output driving stage for the estimated capacitive load.
- \*\* From Up/Down, Binary/Decade, Carry In preset Enable Control Inputs to Clock Edge.
- \*\*\* From Carry In to Clock Edge.

**LOGIC DIAGRAM**

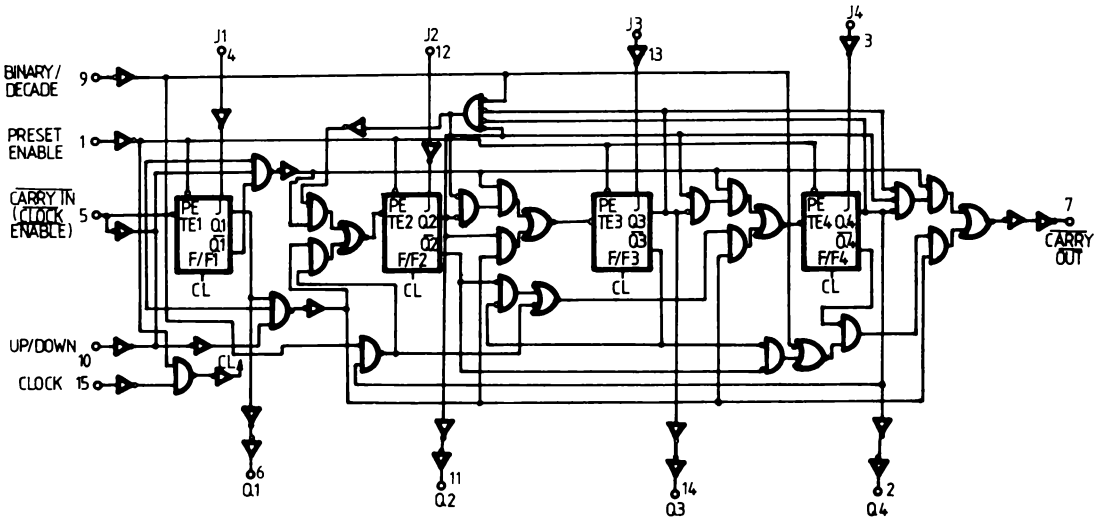

**TRUTH TABLES**

| CLOCK | TE | PE | J | Q         | $\bar{Q}$    |
|-------|----|----|---|-----------|--------------|
| X     | X  | 0  | 0 | 0         | 1            |
|       | 0  | 1  | X | $\bar{Q}$ | Q            |
| X     | X  | 0  | 1 | 1         | 0            |
|       | 1  | 1  | X | Q         | $\bar{Q}$ NC |
|       | X  | 1  | X | Q         | $\bar{Q}$ NC |

X = don't care

| CONTROL INPUT                                       | LOGIC LEVEL | ACTION   |
|---|-------------|--|
| BIN/DEC (B/D)                                       | 1<br>0      | BINARY COUNT<br>DECADE COUNT   |
| UP/DOWN (U/D)                                       | 1<br>0      | UP COUNT<br>DOWN COUNT   |
| PRESET ENABLE (PE)                                  | 1<br>0      | JAM IN<br>NO JAM   |
| $\overline{\text{CARRY IN (CI)}}$<br>(CLOCK ENABLE) | 1<br>0      | NO COUNTER ADVANCE<br>AT POSITIVE CLOCK<br>TRANSITION COUNTER<br>ADVANCE AT POSITIVE<br>CLOCK TRANSITION |

# QUAD EXCLUSIVE-OR GATE

## GENERAL DESCRIPTION

The MMC 4030 is a monolithic integrated circuit, available in 14-lead dual in-line plastic or ceramic package.  
The MMC 4030 consists of four independent Exclusive-OR gates integrated on a single monolithic silicon chip. All inputs and outputs are protected against electrostatic effects.

## FEATURES

- MEDIUM-SPEED OPERATION- $t_{PHL} = t_{PLH} = 65$  ns (TYP.) AT  $C_L = 50$  pF and  $V_{DD}-V_{SS} = 10$  V
- LOW OUTPUT IMPEDANCE: 500  $\Omega$  (TYP.) AT  $V_{DD}-V_{SS} = 10$  V

## APPLICATIONS

- Even and odd-parity generators and checkers
- Logical comparators
- Adders/subtractors
- General logic functions

## ABSOLUTE MAXIMUM RATINGS

|            |  |                    |                  |                              |
|------------|--|--------------------|------------------|------------------------------|
| $V_{DD}^*$ | Supply voltage: G and H types<br>E and F types   | -0.5 to<br>-0.5 to | 20<br>18         | V<br>V                       |
| $V_i$      | Input voltage  | -0.5 to            | $V_{DD} \pm 0.5$ | V                            |
| $I_i$      | DC input current (any one input)   |                    | $\pm 10$         | mA                           |
| $P_{tot}$  | Total power dissipation (per package)<br>Dissipation per output transistor<br>for $T_A =$ full package-temperature range |                    | 200              | mW<br>mW                     |
| $T_A$      | Operating temperature :<br>G and H types<br>E and F types  | -55 to<br>-40 to   | 125<br>85        | $^{\circ}$ C<br>$^{\circ}$ C |
| $T_{stg}$  | Storage temperature  | -65 to             | 150              | $^{\circ}$ C                 |

\* All voltage values are referred to  $V_{SS}$  pin voltage

## RECOMMENDED OPERATING CONDITIONS

|            |   |                  |           |                              |
|------------|---|------------------|-----------|------------------------------|
| $V_{DD}^*$ | Supply voltage: G and H types<br>E and F types            | 3 to<br>3 to     | 18<br>15  | V<br>V                       |
| $V_i$      | Input voltage   | 0 to             | $V_{DD}$  | V                            |
| $T_A$      | Operating temperature :<br>G and H types<br>E and F types | -55 to<br>-40 to | 125<br>85 | $^{\circ}$ C<br>$^{\circ}$ C |

## CONNECTION DIAGRAM

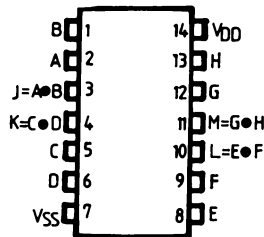

## FUNCTIONAL DIAGRAM

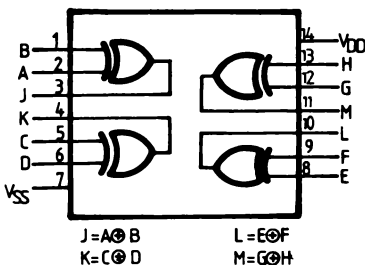

## TRUTH TABLE

One of four identical gates

| A | B | J |
|---|---|---|
| 0 | 0 | 0 |
| 1 | 0 | 1 |
| 0 | 1 | 1 |
| 1 | 1 | 0 |

Where „1” = High level  
„0” = Low level

**STATIC ELECTRICAL CHARACTERISTICS**

(Over recommended operating conditions)

| PARAMETER                         |                       | TEST CONDITIONS       |                       |                                |                        | VALUES             |       |           |       |                        |                     | UNIT  |         |         |
|-----------------------------------|-----------------------|-----------------------|-----------------------|--------------------------------|------------------------|--------------------|-------|-----------|-------|------------------------|---------------------|-------|---------|---------|
|                                   |                       | V <sub>I</sub><br>(V) | V <sub>O</sub><br>(V) | I <sub>O</sub>  <br>( $\mu$ A) | V <sub>DD</sub><br>(V) | T <sub>LOW</sub> * |       | 25°C      |       |                        | T <sub>HIGH</sub> * |       |         |         |
|                                   |                       |                       |                       |                                |                        | min.               | max.  | min.      | typ   | max.                   | min.                |       | max.    |         |
| I <sub>L</sub>                    | Quiescent current     | G, H types            | 0/ 5                  |                                |                        | 5                  |       | 1         |       | 0.02                   | 1                   |       | 30      |         |
|                                   |                       |                       | 0/10                  |                                |                        | 10                 |       | 2         |       | 0.02                   | 2                   |       | 60      |         |
|                                   |                       |                       | 0/15                  |                                |                        | 15                 |       | 4         |       | 0.02                   | 4                   |       | 120     |         |
|                                   |                       |                       | 0/20                  |                                |                        | 20                 |       | 20        |       | 0.04                   | 20                  |       | 600     |         |
|                                   | E, F types            | 0/ 5                  |                       |                                | 5                      |                    | 4     |           | 0.02  | 4                      |                     | 30    |         |         |
|                                   |                       | 0/10                  |                       |                                | 10                     |                    | 8     |           | 0.02  | 8                      |                     | 60    |         |         |
|                                   |                       | 0/15                  |                       |                                | 15                     |                    | 16    |           | 0.02  | 16                     |                     | 120   |         |         |
| V <sub>OH</sub>                   | Output high voltage   | 0/ 5                  |                       | < 1                            | 5                      | 4.95               |       | 4.95      |       |                        | 4.95                |       | V       |         |
|                                   |                       | 0/10                  |                       | < 1                            | 10                     | 9.95               |       | 9.95      |       |                        | 9.95                |       |         |         |
|                                   |                       | 0/15                  |                       | < 1                            | 15                     | 14.95              |       | 14.95     |       |                        | 14.95               |       |         |         |
| V <sub>OL</sub>                   | Output low voltage    | 5 /0                  |                       | < 1                            | 5                      |                    | 0.05  |           |       | 0.05                   |                     | 0.05  | V       |         |
|                                   |                       | 10/0                  |                       | < 1                            | 10                     |                    | 0.05  |           |       | 0.05                   |                     | 0.05  |         |         |
|                                   |                       | 15/0                  |                       | < 1                            | 15                     |                    | 0.05  |           |       | 0.05                   |                     | 0.05  |         |         |
| V <sub>IH</sub>                   | Input high voltage    |                       | 0.5/4.5               | < 1                            | 5                      | 3.5                |       | 3.5       |       |                        | 3.5                 |       | V       |         |
|                                   |                       |                       | 1/9                   | < 1                            | 10                     | 7                  |       | 7         |       |                        | 7                   |       |         |         |
|                                   |                       |                       | 1.5/13.5              | < 1                            | 15                     | 11                 |       | 11        |       |                        | 11                  |       |         |         |
| V <sub>IL</sub>                   | Input low voltage     |                       | 4.5/0.5               | < 1                            | 5                      |                    | 1.5   |           |       | 1.5                    |                     | 1.5   | V       |         |
|                                   |                       |                       | 9/1                   | < 1                            | 10                     |                    | 3     |           |       | 3                      |                     | 3     |         |         |
|                                   |                       |                       | 13.5/1.5              | < 1                            | 15                     |                    | 4     |           |       | 4                      |                     | 4     |         |         |
| I <sub>OH</sub>                   | Output drive current  | G, H types            | 0/ 5                  | 2.5                            |                        | 5                  | -2    |           | -1.6  | -3.2                   |                     | -1.15 |         | mA      |
|                                   |                       |                       | 0/ 5                  | 4.6                            |                        | 5                  | -0.64 |           | -0.51 | -1                     |                     | -0.36 |         |         |
|                                   |                       |                       | 0/10                  | 9.5                            |                        | 10                 | -1.6  |           | -1.3  | -2.6                   |                     | -0.9  |         |         |
|                                   |                       |                       | 0/15                  | 13.5                           |                        | 15                 | -4.2  |           | -3.4  | -6.8                   |                     | -2.4  |         |         |
|                                   |                       | E, F types            | 0/ 5                  | 2.5                            |                        | 5                  | -1.53 |           | -1.36 | -3.2                   |                     | -1.1  |         |         |
|                                   |                       |                       | 0/ 5                  | 4.6                            |                        | 5                  | -0.52 |           | -0.44 | -1                     |                     | -0.36 |         |         |
|                                   |                       | 0/10                  | 9.5                   |                                | 10                     | -1.3               |       | -1.1      | -2.6  |                        | -0.9                |       |         |         |
|                                   |                       | 0/15                  | 13.5                  |                                | 15                     | -3.6               |       | -3.0      | -6.8  |                        | -2.4                |       |         |         |
| I <sub>OL</sub>                   | Output sink current   | G, H types            | 0/ 5                  | 0.4                            |                        | 5                  | 0.64  |           | 0.51  | 1                      |                     | 0.36  |         | mA      |
|                                   |                       |                       | 0/10                  | 0.5                            |                        | 10                 | 1.6   |           | 1.3   | 2.6                    |                     | 0.9   |         |         |
|                                   |                       |                       | 0/15                  | 1.5                            |                        | 15                 | 4.2   |           | 3.4   | 6.8                    |                     | 2.4   |         |         |
|                                   |                       |                       | 0/ 5                  | 0.4                            |                        | 5                  | 0.52  |           | 0.44  | 1                      |                     | 0.36  |         |         |
|                                   |                       | E, F types            | 0/10                  | 0.5                            |                        | 10                 | 1.3   |           | 1.1   | 2.6                    |                     | 0.9   |         |         |
|                                   |                       |                       | 0/15                  | 1.5                            |                        | 15                 | 3.6   |           | 3.0   | 6.8                    |                     | 2.4   |         |         |
| I <sub>IH</sub> , I <sub>IL</sub> | Input leakage current | G, H types            | 0/18                  | Any input                      |                        | 18                 |       | $\pm$ 0.1 |       | $\pm$ 10 <sup>-5</sup> | $\pm$ 0.1           |       | $\pm$ 1 | $\mu$ A |
|                                   |                       | E, F types            | 0/15                  |                                |                        | 15                 |       | $\pm$ 0.3 |       | $\pm$ 10 <sup>-5</sup> | $\pm$ 0.3           |       | $\pm$ 1 |         |
| C <sub>I</sub>                    | Input capacitance     |                       | Any input             |                                |                        |                    |       |           | 5     | 7.5                    |                     |       | pF      |         |

\* T<sub>LOW</sub> = -55°C for G, H devices; -40°C for E, F devices.

\* T<sub>HIGH</sub> = +125°C for G, H devices; +85°C for E, F devices.

The Noise Margin for both "1" and "0" level is:

- 1 V min. with V<sub>DD</sub> = 5 V
- 2 V min. with V<sub>DD</sub> = 10 V
- 2.5 V min. with V<sub>DD</sub> = 15 V

**DYNAMIC ELECTRICAL CHARACTERISTICS**

( $T_A = 25\text{ }^\circ\text{C}$ ,  $C_L = 50\text{ pF}$ ,  $R_L = 200\text{ kohm}$ , typical temperature coefficient for all  $V_{DD} = 0.3\%/^\circ\text{C}$  values, all input rise and fall time = 20 ns).

| PARAMETER                                       | TEST CONDITIONS | VALUES |     |     | UNIT |
|---|-----------------|--------|-----|-----|------|
|   | $V_{DD}$ (V)    | min    | typ | max |      |
| $t_{PLH}$ , Propagation delay time<br>$t_{PHL}$ | 5               |        | 140 | 280 | ns   |
|   | 10              |        | 65  | 130 |      |
|   | 15              |        | 50  | 100 |      |
| $t_{TLH}$ , Transition time<br>$t_{THL}$        | 5               |        | 100 | 200 | ns   |
|   | 10              |        | 50  | 100 |      |
|   | 15              |        | 40  | 80  |      |

**TYPICAL APPLICATIONS**

Even-parity-bit generator  
(13/4 x MMC 4030)

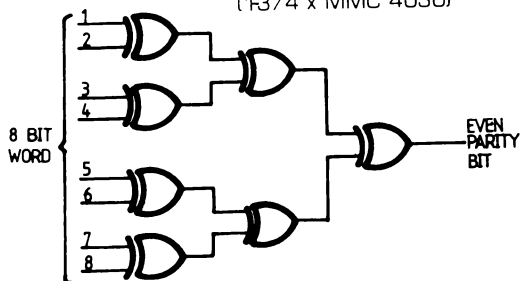

Even-parity checker  
(2 x MMC 4030)

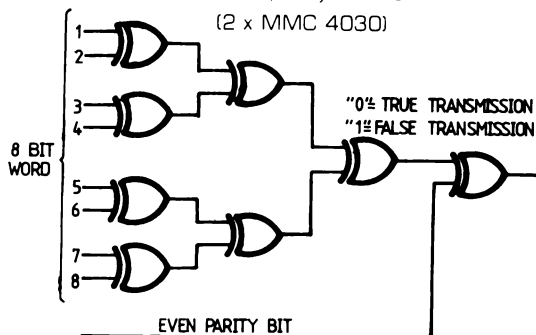

Odd-parity-bit generator  
(2 x MMC 4030)

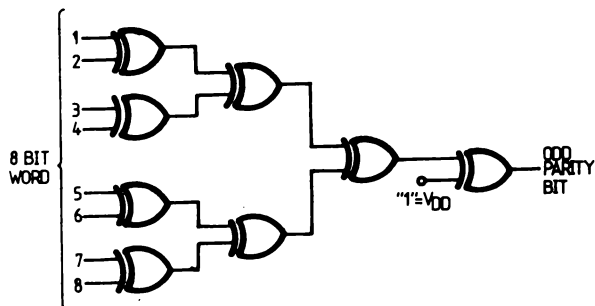

Odd-parity checker  
(2 x MMC 4030)

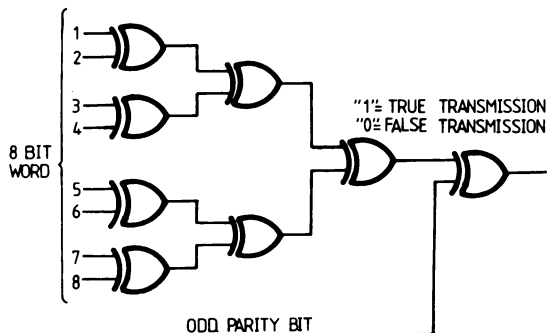



8-bit comparator

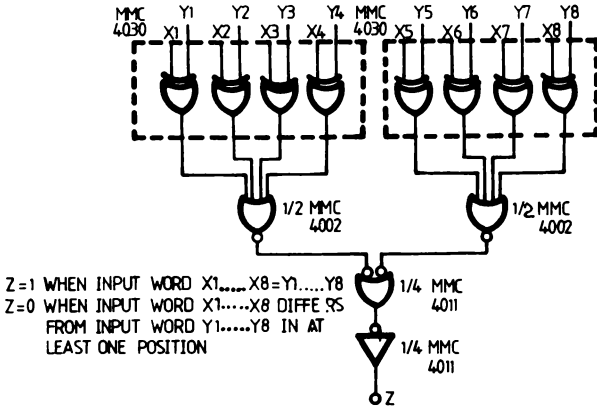

8-bit two's complement adder-subtractor

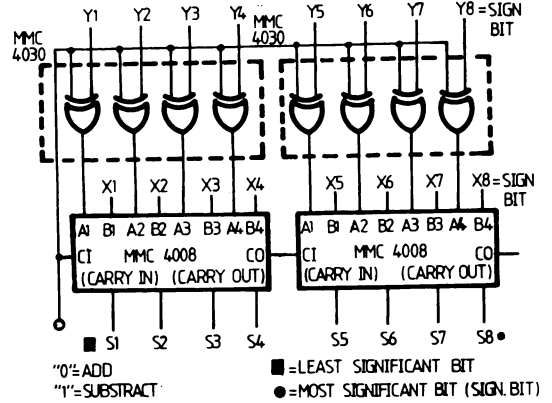

TABLE 1

Two's complement numbers and their equivalent decimal values

| X <sub>8</sub> | X <sub>7</sub> | X <sub>6</sub> | X <sub>5</sub> | X <sub>4</sub> | X <sub>3</sub> | X <sub>2</sub> | X <sub>1</sub> | X <sub>8</sub> | X <sub>7</sub> | X <sub>6</sub> | X <sub>5</sub> | X <sub>4</sub> | X <sub>3</sub> | X <sub>2</sub> | X <sub>1</sub> |
|----------------|----------------|----------------|----------------|----------------|----------------|----------------|----------------|----------------|----------------|----------------|----------------|----------------|----------------|----------------|----------------|
| 0              | 0              | 0              | 0              | 0              | 0              | 0              | 0              | 1              | 1              | 1              | 1              | 1              | 1              | 1              | 1              |
| 0              | 0              | 0              | 0              | 0              | 0              | 0              | 1              | 1              | 1              | 1              | 1              | 1              | 1              | 1              | 0              |
| 0              | 0              | 0              | 0              | 0              | 0              | 1              | 1              | 1              | 1              | 1              | 1              | 1              | 1              | 0              | 1              |
| 0              | 0              | 0              | 0              | 0              | 0              | 1              | 1              | 1              | 1              | 1              | 1              | 1              | 0              | 1              | 1              |
| 0              | 1              | 1              | 1              | 1              | 1              | 1              | 0              | 1              | 0              | 0              | 0              | 0              | 0              | 0              | 1              |
| 0              | 1              | 1              | 1              | 1              | 1              | 1              | 1              | 1              | 0              | 0              | 0              | 0              | 0              | 0              | 0              |

The two's complement adder-subtractor can add or subtract any two of the numbers in TABLE 1.

For example

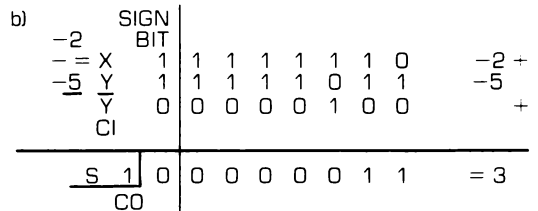
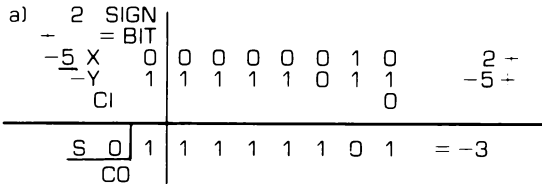

# 64-STAGE STATIC SHIFT REGISTER

## GENERAL DESCRIPTION

The MMC 4031 is a static shift register that contains 64 D-type, master-slave flip-flop stages and one stage which is a D-type master flip-flop.

The MMC 4031 is a monolithic integrated circuit, fabricated in standard Al-gate CMOS technology. It is available in 16-lead dual in-line plastic and ceramic package.

The logic level present at the DATA input of MMC 4031 is transferred into the first stage and shifted one stage at each positive-going clock transition. The MMC 4031 has a MODE CONTROL input that when in the high state, allows operation in the recirculating mode. The MODE CONTROL input can also be used to select between two separate data sources. A delayed clock output (CL<sub>D</sub>) is provided that enables cascading register packages while allowing reduced clock drive fan-out and transition-time requirements. A third cascading option makes use of the Q' output from the 1/2 stage, which is available on the next negative-going transition of the clock after the Q output occurs. This delayed output is used with clocks having slow rise and fall times.

## FEATURES

- Fully static operation: dc to 16 MHz, V<sub>DD</sub> = V<sub>SS</sub> = 15 V
- Standard TTL drive capability on Q output
- Three cascading modes:
  - direct clocking for high-speed operation
  - delayed clocking for reduced clock drive requirements
  - additional 1/2 stage for slow clocks
- Recirculation capability

## ABSOLUTE MAXIMUM RATINGS

|                   |  |  |             |
|-------------------|--|--|-------------|
| V <sub>DD</sub> * | Supply voltage: G and H types<br>E and F types   | -0.5 to 20<br>-0.5 to 18<br>-0.5 to 15 | V<br>V<br>V |
| V <sub>i</sub>    | Input voltage  | V <sub>DD</sub> +0.5                   | V           |
| I <sub>i</sub>    | DC input current (any one input)   | ± 10                                   | mA          |
| P <sub>tot</sub>  | Total power dissipation (per package)  | 200                                    | mW          |
|                   | Dissipation per output transistor<br>for T <sub>A</sub> = full package-temperature range | 100                                    | mW          |
| T <sub>A</sub>    | Operating temperature : G and H types<br>E and F types                                   | -55 to 125<br>-40 to 85                | °C<br>°C    |
| T <sub>stg</sub>  | Storage temperature  | -65 to 150                             | °C          |

\* All voltage values are referred to V<sub>SS</sub> pin voltage

## RECOMMENDED OPERATING CONDITIONS

|                   |  |  |             |
|-------------------|--|--|-------------|
| V <sub>DD</sub> * | Supply voltage: G and H types<br>E and F types         | 3 to 18<br>3 to 15<br>0 to V <sub>DD</sub> | V<br>V<br>V |
| V <sub>i</sub>    | Input voltage  | V <sub>DD</sub>                            | V           |
| T <sub>A</sub>    | Operating temperature : G and H types<br>E and F types | -55 to 125<br>-40 to 85                    | °C<br>°C    |

## CONNECTION DIAGRAM

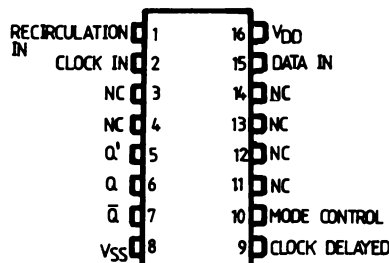

**LOGIC DIAGRAM AND TRUTH TABLES**

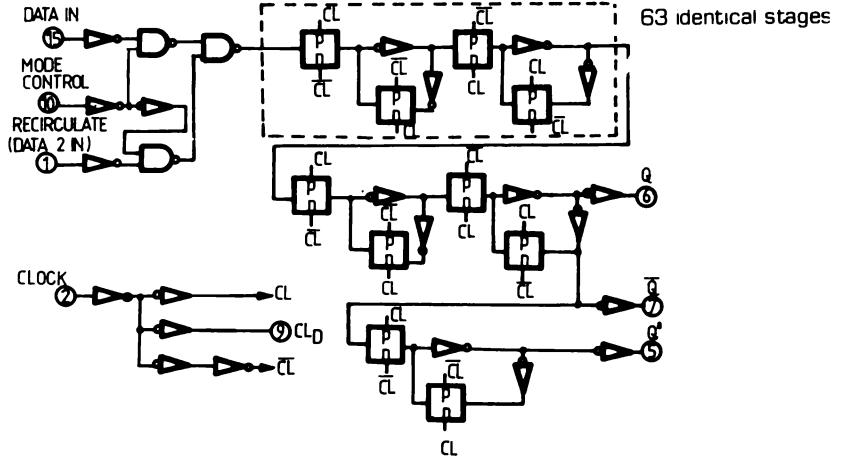

**INPUT CONTROL CIRCUIT**

| DATA | RECIRC. | MODE | BIT INTO STAGE 1 |
|------|---------|------|------------------|
| 1    | X       | 0    | 1                |
| 0    | X       | 0    | 0                |
| X    | 1       | 1    | 1                |
| X    | 0       | 1    | 0                |

1 = HIGH LEVEL, 0 = LOW LEVEL,  
X = DON'T CARE

**OUTPUT FROM Q' (PIN 5)**

| Data + 64 | CL | Data + 64.5 |
|-----------|----|-------------|
| 0         |    | 0           |
| 1         |    | 1           |
| X         |    | NC          |

1 = HIGH LEVEL, 0 = LOW LEVEL,  
X = DON'T CARE, NC = NO CHANGE

**TYPICAL STAGE**

| Data | CL | Data + 1 |
|------|----|----------|
| 0    |    | 0        |
| 1    |    | 1        |
| X    |    | NC       |

1 = HIGH LEVEL, 0 = LOW LEVEL,  
X = DON'T CARE, NC = NO CHANGE

**STATIC ELECTRICAL CHARACTERISTICS**

(over recommended operating conditions)

| PARAMETER                         |  | TEST CONDITIONS       |                            |                                 |                        | VALUES                |                      |                       |               |                      |                       | UNIT    |         |
|-----------------------------------|--|-----------------------|----------------------------|---------------------------------|------------------------|-----------------------|----------------------|-----------------------|---------------|----------------------|-----------------------|---------|---------|
|                                   |  | V <sub>I</sub><br>(V) | V <sub>O</sub><br>(V)      | I <sub>oI</sub>  <br>( $\mu$ A) | V <sub>DD</sub><br>(V) | T <sub>LOW</sub>      |                      | 25°C                  |               |                      | T <sub>HIGH</sub>     |         |         |
|                                   |  |                       |                            |                                 |                        | min.                  | max.                 | min.                  | typ           | max.                 | min.                  |         | max.    |
| I <sub>L</sub>                    | Quiescent current  | G, H types            | 0/ 5                       |                                 |                        | 5                     |                      | 5                     |               | 0.04                 | 5                     | 150     | $\mu$ A |
|                                   |  |                       | 0/10                       |                                 |                        | 10                    |                      | 10                    |               | 0.04                 | 10                    | 300     |         |
| 0/15                              |  |                       |                            |                                 | 15                     |                       | 20                   |                       | 0.04          | 20                   | 600                   |         |         |
| 0/20                              |  |                       |                            |                                 | 20                     |                       | 100                  |                       | 0.08          | 100                  | 3000                  |         |         |
|                                   | E, F types   | 0/ 5                  |                            |                                 | 5                      |                       | 20                   |                       | 0.04          | 20                   | 150                   |         |         |
| 0/10                              |  |                       |                            | 10                              |                        | 40                    |                      | 0.04                  | 40            | 300                  |                       |         |         |
| 0/15                              |  |                       |                            | 15                              |                        | 80                    |                      | 0.04                  | 80            | 600                  |                       |         |         |
| V <sub>OH</sub>                   | Output high voltage  |                       | 0/ 5<br>0/10<br>0/15       | < 1<br>< 1<br>< 1               | 5<br>10<br>15          | 4.95<br>9.95<br>14.95 |                      | 4.95<br>9.95<br>14.95 |               |                      | 4.95<br>9.95<br>14.95 | V       |         |
| V <sub>OL</sub>                   | Output low voltage   |                       | 5 /0<br>10/0<br>15/0       | < 1<br>< 1<br>< 1               | 5<br>10<br>15          |                       | 0.05<br>0.05<br>0.05 |                       |               | 0.05<br>0.05<br>0.05 | 0.05<br>0.05<br>0.05  | V       |         |
| V <sub>IH</sub>                   | Input high voltage   |                       | 0.5/4.5<br>1/9<br>1.5/13.5 | < 1<br>< 1<br>< 1               | 5<br>10<br>15          | 3.5<br>7<br>11        |                      | 3.5<br>7<br>11        |               |                      | 3.5<br>7<br>11        | V       |         |
| V <sub>IL</sub>                   | Input low voltage  |                       | 4.5/0.5<br>9/1<br>13.5/1.5 | < 1<br>< 1<br>< 1               | 5<br>10<br>15          |                       | 1.5<br>3<br>4        |                       |               | 1.5<br>3<br>4        | 1.5<br>3<br>4         | V       |         |
| I <sub>OH</sub>                   | Output source current<br>(source)<br>Q, $\bar{Q}$ , Q<br>CL <sub>D</sub> | G, H types            | 0/ 5                       | 2.5                             |                        | 5                     | -2                   |                       | -1.6          | -3.2                 |                       | -1.15   | mA      |
|                                   |  |                       | 0/ 5                       | 4.6                             |                        | 5                     | -0.64                |                       | -0.51         | -1                   |                       | -0.36   |         |
| 0/10                              |  |                       | 9.5                        |                                 | 10                     | -1.6                  |                      | -1.3                  | -2.6          |                      | -0.9                  |         |         |
| 0/15                              |  |                       | 13.5                       |                                 | 15                     | -4.2                  |                      | -3.4                  | -6.8          |                      | -2.4                  |         |         |
|                                   |  | E, F types            | 0/ 5                       | 2.5                             |                        | 5                     | -1.53                |                       | -1.36         | -3.2                 |                       | -1.1    |         |
| 0/ 5                              |  |                       | 4.6                        |                                 | 5                      | -0.52                 |                      | -0.44                 | -1            |                      | -0.36                 |         |         |
|                                   | E, F types   | 0/10                  | 9.5                        |                                 | 10                     | -1.3                  |                      | -1.1                  | -2.6          |                      | -0.9                  |         |         |
| 0/15                              |  | 13.5                  |                            | 15                              | -3.6                   |                       | -3.0                 | -6.8                  |               | -2.4                 |                       |         |         |
| I <sub>OL</sub>                   | Output sink current<br>Q   | G, H types            | 0/ 5                       | 0.4                             |                        | 5                     | 2.56                 |                       | 2.04          | 4                    |                       | 1.44    | mA      |
|                                   |  |                       | 0/10                       | 0.5                             |                        | 10                    | 6.4                  |                       | 5.2           | 10.4                 |                       | 3.6     |         |
| 0/15                              |  |                       | 1.5                        |                                 | 15                     | 16.8                  |                      | 13.6                  | 27.2          |                      | 9.6                   |         |         |
|                                   |  |                       | E, F types                 | 0/ 5                            | 0.4                    |                       | 5                    | 2.08                  |               | 1.74                 | 4                     |         |         |
| 0/10                              |  | 0.5                   |                            |                                 | 10                     | 5.01                  |                      | 4.42                  | 10.4          |                      | 3.74                  |         |         |
|                                   |  | E, F types            | 0/15                       | 1.5                             |                        | 15                    | 13.6                 |                       | 11.56         | 27.2                 |                       | 9.52    |         |
| I <sub>OL</sub>                   | Output sink current<br>$\bar{Q}$ , Q'<br>CL <sub>D</sub>                 |                       | G, H types                 | 0/ 5                            | 0.4                    |                       | 5                    | 0.64                  |               | 0.51                 | 1                     |         | 0.36    |
|                                   |  | 0/10                  |                            | 0.5                             |                        | 10                    | 1.6                  |                       | 1.3           | 2.6                  |                       | 0.9     |         |
| 0/15                              |  | 1.5                   |                            |                                 | 15                     | 4.2                   |                      | 3.4                   | 6.8           |                      | 2.4                   |         |         |
|                                   |  | E, F types            |                            | 0/ 5                            | 0.4                    |                       | 5                    | 0.52                  |               | 0.44                 | 1                     |         | 0.36    |
| 0/10                              |  |                       | 0.5                        |                                 | 10                     | 1.3                   |                      | 1.1                   | 2.6           |                      | 0.9                   |         |         |
|                                   |  | E, F types            | 0/15                       | 1.5                             |                        | 15                    | 3.6                  |                       | 3.0           | 6.8                  |                       | 2.4     |         |
| I <sub>IH</sub> , I <sub>IL</sub> | Input leakage current  |                       | G, H types                 | 0/18                            | Any input              | 18                    |                      | $\pm 0.1$             |               | $\pm 10^{-5}$        | $\pm 0.1$             |         | $\pm 1$ |
|                                   |  | E, F types            | 0/15                       | 15                              |                        |                       | $\pm 0.3$            |                       | $\pm 10^{-5}$ | $\pm 0.3$            |                       | $\pm 1$ |         |

| PARAMETER                        | TEST CONDITIONS       |                       |                                |                        | VALUES             |      |      |      |      |                     | UNIT |      |
|----------------------------------|-----------------------|-----------------------|--------------------------------|------------------------|--------------------|------|------|------|------|---------------------|------|------|
|                                  | V <sub>I</sub><br>(V) | V <sub>O</sub><br>(V) | I <sub>O</sub>  <br>( $\mu$ A) | V <sub>DD</sub><br>(V) | T <sub>LOW</sub> * |      | 25°C |      |      | T <sub>HIGH</sub> * |      |      |
|                                  |                       |                       |                                |                        | min.               | max. | min. | typ. | max. | min.                |      | max. |
| C <sub>I</sub> Input capacitance | Any input             |                       |                                |                        |                    |      |      | 5    | 7.5  |                     |      | pF   |

- \* T<sub>LOW</sub> = -55°C for G, H devices; -40°C for E, F devices.
- \* T<sub>HIGH</sub> = +125°C for G, H devices; +85°C for E, F devices.

The Noise Margin for both "1" and "0" level is:  
 1 V min. with V<sub>DD</sub> = 5 V  
 2 V min. with V<sub>DD</sub> = 10 V  
 2.5 V min. with V<sub>DD</sub> = 15 V

**DYNAMIC ELECTRICAL CHARACTERISTICS**

(T<sub>A</sub> = 25°C, C<sub>L</sub> = 50 pF, R<sub>L</sub> = 200 k, typical temperature coefficient for all V<sub>DD</sub> values is 0.3%/°C, all input rise and fall times = 20 ns)

| PARAMETER   | TEST CONDITIONS<br>V <sub>DD</sub> (V) | VALUES      |                  |                     | UNIT    |
|---|--|-------------|------------------|---------------------|---------|
|   |  | min.        | typ.             | max.                |         |
| t <sub>PHL</sub> , t <sub>PLH</sub> Propagation delay time:<br>Clock to $\bar{Q}$ ,<br>Clock to Q | 5<br>10<br>15                          |             | 250<br>110<br>90 | 500<br>220<br>180   | ns      |
| t <sub>PHL</sub> , t <sub>PLH</sub> Propagation delay time:<br>Clock to Q'<br>Clock to Q          | 5<br>10<br>15                          |             | 190<br>80<br>65  | 380<br>160<br>130   | ns      |
| Clock to CL <sub>D</sub>  | 5                                      |             | 100              | 200                 | ns      |
|   | 10                                     |             | 50               | 100                 |         |
|   | 15                                     |             | 40               | 80                  |         |
| t <sub>THL</sub> , t <sub>TLH</sub> Transition time<br>(any output, except Q t <sub>THL</sub> )   | 5<br>10<br>15                          |             | 100<br>50<br>40  | 200<br>100<br>80    | ns      |
| t <sub>THL</sub> Q  | 5<br>10<br>15                          |             | 50<br>25<br>20   | 100<br>50<br>40     | ns      |
| t <sub>setup</sub> Data setup time  | 5<br>10<br>15                          |             | 30<br>15<br>10   | 60<br>30<br>20      | ns      |
| t <sub>hold</sub> Data hold time  | 5<br>10<br>15                          |             | 30<br>15<br>10   | 60<br>30<br>20      | ns      |
| t <sub>w</sub> Clock pulse width  | 5<br>10<br>15                          |             | 120<br>50<br>40  | 240<br>100<br>80    | ns      |
| t <sub>max</sub> Maximum clock input frequency**  | 5<br>10<br>15                          | 2<br>5<br>6 | 4<br>10<br>12    |                     | MHz     |
| t <sub>r</sub> , t <sub>f</sub> * Clock input rise or fall time                                   | 5<br>10<br>15                          |             |                  | 1000<br>1000<br>200 | $\mu$ s |

\* If more than one unit is cascaded in the parallel clocked application, t<sub>r</sub>CL should be made less than or equal to the sum of the propagation delay at 50 pF and the transition time of the output driving stage.

\*\* Maximum clock frequency for cascaded units;

a) Using delayed clock feature in recirculation mode:

$$f_{max} = \frac{1}{(n-1) CL_{Dprop. delay} + Q prop. delay + set-up time}$$

where n=number of packages.

b) Not using delayed clock:

$$f_{max} = \frac{1}{propagation delay + set-up time}$$

# 4-STAGE PARALLEL IN/PARALLEL OUT SHIFT REGISTER

## GENERAL DESCRIPTION

The MMC 4035 (G and H types) and MMC 4035 (E and F types) are monolithic integrated circuit, available in 16-lead dual in-line plastic or ceramic package. The MMC 4035 integrated circuit is a four-stage clocked signal serial register with provision for synchronous PARALLEL inputs to each stage and SERIAL inputs to the first stage via JK logic. Register stages 2, 3, and 4 are coupled in a serial D flip-flop configuration when the register is in the serial mode (PARALLEL/SERIAL control low). Parallel entry into each register stage is permitted when the PARALLEL/SERIAL control is high. In the parallel or serial mode information is transferred on positive clock transition. When the TRUE/COMPLEMENT control is high, the true contents of the register are available at the output terminals. When the TRUE/COMPLEMENT control is low, the outputs are the complements of the data in the register. The TRUE/COMPLEMENT control functions asynchronously with respect to the CLOCK signal. JK input logic is provided on the first stage SERIAL input to minimize logic requirements particularly in counting and sequence-generation applications. With JK inputs connected together, the first stage becomes a D flip-flop. An asynchronous common RESET is also provided.

ded on the first stage SERIAL input to minimize logic requirements particularly in counting and sequence-generation applications. With JK inputs connected together, the first stage becomes a D flip-flop. An asynchronous common RESET is also provided.

## FEATURES

- 4-stage clocked shift operation
- Synchronous parallel entry on all 4 stages
- JK inputs on first stage
- Asynchronous TRUE/COMPLEMENT control on all outputs
- Static flip-flop operation; master-slave configuration
- Buffered inputs and outputs
- High speed 12 MHz (typ.) at  $V_{DD} = 10$  V.

## ABSOLUTE MAXIMUM RATINGS

|            |  |  |                |
|------------|--|--|----------------|
| $V_{DD}^*$ | Supply voltage: G and H types<br>E and F types                               | -0.5 to 20<br>-0.5 to 18<br>-0.5 to $V_{DD}+0.5$ | V<br>V<br>V    |
| $V_i$      | Input voltage  | $V_{DD}+0.5$                                     | V              |
| $I_i$      | DC input current (any one input)   | $\pm 10$   | mA             |
| $P_{tot}$  | Total power dissipation (per package)  | 200  | mW             |
|            | Dissipation per output transistor for $T_A =$ full package-temperature range | 100  | mW             |
| $T_A$      | Operating temperature :  | -55 to 125<br>-40 to 85<br>-65 to 150            | °C<br>°C<br>°C |
| $T_{stg}$  | Storage temperature  |  |                |

\* All voltage values are referred to  $V_{SS}$  pin voltage

## RECOMMENDED OPERATING CONDITIONS

|            |  |                                     |             |
|------------|--|-------------------------------------|-------------|
| $V_{DD}^*$ | Supply voltage: G and H types<br>E and F types | 3 to 18<br>3 to 15<br>0 to $V_{DD}$ | V<br>V<br>V |
| $V_i$      | Input voltage                                  |                                     |             |
| $T_A$      | Operating temperature :                        | -55 to 125<br>-40 to 85             | °C<br>°C    |

## CONNECTION DIAGRAM

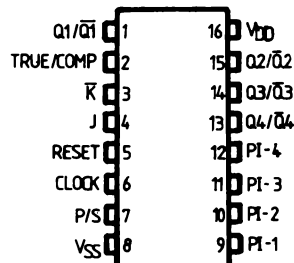

FUNCTIONAL DIAGRAM

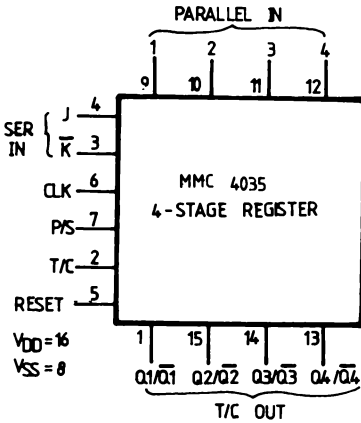

TRUTH TABLE

FIRST STAGE

| CLOCK (φ) | t <sub>n-1</sub> (INPUTS) |   |   |                  | t <sub>n</sub> (OUTPUTS)     |  |
|-----------|---------------------------|---|---|------------------|------------------------------|--|
|           | J                         | K | R | Q <sub>n-1</sub> | Q <sub>n</sub>               |  |
|           | 0                         | X | 0 | 0                | 0                            |  |
|           | 1                         | X | 0 | 0                | 1                            |  |
|           | X                         | 0 | 0 | 1                | 0                            |  |
|           | 1                         | 0 | 0 | Q <sub>n-1</sub> | Q <sub>n-1</sub> TOGGLE MODE |  |
|           | X                         | 1 | 0 | 1                | 1                            |  |
|           | X                         | X | 0 | Q <sub>n-1</sub> | Q <sub>n-1</sub>             |  |
| X         | X                         | X | 1 | X                | 0                            |  |

STATIC ELECTRICAL CHARACTERISTICS

(over recommended operating conditions)

| PARAMETER       |                      | TEST CONDITIONS    |                    |                       |                     | VALUES           |       |      |       |      |                   | UNIT  |      |    |
|-----------------|----------------------|--------------------|--------------------|-----------------------|---------------------|------------------|-------|------|-------|------|-------------------|-------|------|----|
|                 |                      | V <sub>I</sub> (V) | V <sub>O</sub> (V) | I <sub>O</sub>   (μA) | V <sub>DD</sub> (V) | T <sub>LOW</sub> |       | 25°C |       |      | T <sub>HIGH</sub> |       |      |    |
|                 |                      |                    |                    |                       |                     | min.             | max.  | min. | typ.  | max. | min.              |       | max. |    |
| I <sub>L</sub>  | Quiescent current    | G, H types         | 0/ 5               |                       |                     | 5                |       | 5    |       | 0.04 | 5                 |       | 150  | μA |
|                 |                      |                    | 0/10               |                       |                     | 10               |       | 10   |       | 0.04 | 10                |       | 300  |    |
|                 |                      |                    | 0/15               |                       |                     | 15               |       | 20   |       | 0.04 | 20                |       | 600  |    |
|                 |                      |                    | 0/20               |                       |                     | 20               |       | 100  |       | 0.08 | 100               |       | 3000 |    |
|                 | E, F types           | 0/ 5               |                    |                       | 5                   |                  | 20    |      | 0.04  | 20   |                   | 150   |      |    |
|                 |                      | 0/10               |                    |                       | 10                  |                  | 40    |      | 0.04  | 40   |                   | 300   |      |    |
| V <sub>OH</sub> | Output high voltage  | G, H types         | 0/ 5               |                       | < 1                 | 5                | 4.95  |      | 4.95  |      |                   | 4.95  |      | V  |
|                 |                      |                    | 0/10               |                       | < 1                 | 10               | 9.95  |      | 9.95  |      |                   | 9.95  |      |    |
|                 |                      |                    | 0/15               |                       | < 1                 | 15               | 14.95 |      | 14.95 |      |                   | 14.95 |      |    |
| V <sub>OL</sub> | Output low voltage   | G, H types         | 5 /0               |                       | < 1                 | 5                |       | 0.05 |       | 0.05 |                   | 0.05  | V    |    |
|                 |                      |                    | 10/0               |                       | < 1                 | 10               |       | 0.05 |       | 0.05 |                   | 0.05  |      |    |
|                 |                      |                    | 15/0               |                       | < 1                 | 15               |       | 0.05 |       | 0.05 |                   | 0.05  |      |    |
| V <sub>IH</sub> | Input high voltage   | G, H types         | 0.5/4.5            |                       | < 1                 | 5                | 3.5   |      | 3.5   |      |                   | 3.5   | V    |    |
|                 |                      |                    | 1/9                |                       | < 1                 | 10               | 7     |      | 7     |      |                   | 7     |      |    |
|                 |                      |                    | 1.5/13.5           |                       | < 1                 | 15               | 11    |      | 11    |      |                   | 11    |      |    |
| V <sub>IL</sub> | Input low voltage    | G, H types         | 4.5/0.5            |                       | < 1                 | 5                |       | 1.5  |       | 1.5  |                   | 1.5   | V    |    |
|                 |                      |                    | 9/1                |                       | < 1                 | 10               |       | 3    |       | 3    |                   | 3     |      |    |
|                 |                      |                    | 13.5/1.5           |                       | < 1                 | 15               |       | 4    |       | 4    |                   | 4     |      |    |
| I <sub>OH</sub> | Output drive current | G, H types         | 0/ 5               | 2.5                   |                     | 5                | -2    |      | -1.6  | -3.2 |                   | -1.15 | mA   |    |
|                 |                      |                    | 0/ 5               | 4.6                   |                     | 5                | -0.64 |      | -0.51 | -1   |                   | -0.36 |      |    |
|                 |                      |                    | 0/10               | 9.5                   |                     | 10               | -1.6  |      | -1.3  | -2.6 |                   | -0.9  |      |    |
|                 |                      |                    | 0/15               | 13.5                  |                     | 15               | -4.2  |      | -3.4  | -6.8 |                   | -2.4  |      |    |
|                 |                      | E, F types         | 0/ 5               | 2.5                   |                     | 5                | -1.53 |      | -1.36 | -3.2 |                   | -1.1  |      |    |
|                 |                      |                    | 0/ 5               | 4.6                   |                     | 5                | -0.52 |      | -0.44 | -1   |                   | -0.36 |      |    |
| E, F types      | 0/10                 | 9.5                |                    | 10                    | -1.3                |                  | -1.1  | -2.6 |       | -0.9 |                   |       |      |    |
|                 | 0/15                 | 13.5               |                    | 15                    | -3.6                |                  | -3.0  | -6.8 |       | -2.4 |                   |       |      |    |

**STATIC ELECTRICAL CHARACTERISTICS**

(over recommended operating conditions)

| PARAMETER                         |                       | TEST CONDITIONS       |                       |                           |                        | VALUES             |      |      |      |                   |                     | UNIT |      |
|-----------------------------------|-----------------------|-----------------------|-----------------------|---------------------------|------------------------|--------------------|------|------|------|-------------------|---------------------|------|------|
|                                   |                       | V <sub>I</sub><br>(V) | V <sub>O</sub><br>(V) | I <sub>O1</sub>  <br>(μA) | V <sub>DD</sub><br>(V) | T <sub>LOW</sub> * |      | 25°C |      |                   | T <sub>HIGH</sub> * |      |      |
|                                   |                       |                       |                       |                           |                        | min.               | max. | min. | typ. | max.              | min.                |      | max. |
| I <sub>OL</sub>                   | Output sink current   | G, H types            | 0/ 5                  | 0.4                       |                        | 5                  | 0.64 |      | 0.51 | 1                 |                     | 0.36 | mA   |
|                                   |                       |                       | 0/10                  | 0.5                       |                        | 10                 | 1.6  |      | 1.3  | 2.6               |                     | 0.9  |      |
|                                   |                       |                       | 0/15                  | 1.5                       | 15                     | 4.2                |      | 3.4  | 6.8  |                   | 2.4                 |      |      |
|                                   |                       | E, F types            | 0/ 5                  | 0.4                       |                        | 5                  | 0.52 |      | 0.44 | 1                 |                     | 0.36 |      |
|                                   |                       |                       | 0/10                  | 0.5                       |                        | 10                 | 1.3  |      | 1.1  | 2.6               |                     | 0.9  |      |
|                                   |                       |                       | 0/15                  | 1.5                       | 15                     | 3.6                |      | 3.0  | 6.8  |                   | 2.4                 |      |      |
| I <sub>IH</sub> , I <sub>IL</sub> | Input leakage current | G, H types            | 0/18                  | Any input                 |                        | 18                 |      | ±0.1 |      | ±10 <sup>-5</sup> | ±0.1                |      | ±1   |
|                                   |                       | E, F types            | 0/15                  |                           |                        | 15                 |      | ±0.3 |      | ±10 <sup>-5</sup> | ±0.3                |      | ±1   |
| C <sub>I</sub>                    | Input capacitance     |                       |                       | Any input                 |                        |                    |      |      | 5    | 7.5               |                     |      | pF   |

\* T<sub>LOW</sub> = -55°C for G, H devices; -40°C for E, F devices.

\* T<sub>HIGH</sub> = +125°C for G, H devices; +85°C for E, F devices.

The Noise Margin for both "1" and "0" level is:

1 V min. with V<sub>DD</sub> = 5 V

2 V min. with V<sub>DD</sub> = 10 V

2.5 V min. with V<sub>DD</sub> = 15 V

**DYNAMIC ELECTRICAL CHARACTERISTICS**

(T<sub>A</sub> = 25°C, C<sub>L</sub> = 50 pF, R<sub>L</sub> = 200 kohm, typical temperature coefficient for all V<sub>DD</sub> = 0.3%/°C values, all input rise and fall time = 20 ns)

| PARAMETER                              |                               | TEST CONDITIONS<br>V <sub>DD</sub> (V) | VALUES |      |      | Unit |
|--|-------------------------------|--|--------|------|------|------|
|  |                               |  | min.   | typ. | max. |      |
| t <sub>PLH</sub> ,<br>t <sub>PHL</sub> | Propagation delay time        | 5                                      |        | 250  | 500  | ns   |
|  |                               | 10                                     |        | 100  | 200  |      |
|  |                               | 15                                     |        | 75   | 150  |      |
| t <sub>THL</sub> ,<br>t <sub>TLH</sub> | Transition time               | 5                                      |        | 100  | 200  | ns   |
|  |                               | 10                                     |        | 50   | 100  |      |
|  |                               | 15                                     |        | 40   | 80   |      |
| f <sub>CL</sub>                        | Maximum clock input frequency | 5                                      | 2      | 4    |      | MHz  |
|  |                               | 10                                     | 6      | 12   |      |      |
|  |                               | 15                                     | 8      | 16   |      |      |
| t <sub>w</sub>                         | Clock pulse width             | 5                                      |        | 100  | 200  | ns   |
|  |                               | 10                                     |        | 45   | 90   |      |
|  |                               | 15                                     |        | 30   | 60   |      |
| t <sub>r</sub> , t <sub>f</sub>        | Clock input rise or fall time | 5                                      |        | 15   |      | μs   |
|  |                               | 10                                     |        | 15   |      |      |
|  |                               | 15                                     |        | 15   |      |      |



| PARAMETER                                      | TEST CONDITIONS<br>$V_{DD}$ (V) | VALUES |      |      | Unit |
|--|---------------------------------|--------|------|------|------|
|  |                                 | min.   | typ. | max. |      |
| $t_{setup}$ Data setup time J/ $\bar{K}$ lines | 5                               |        | 110  | 220  | ns   |
|  | 10                              |        | 40   | 80   |      |
|  | 15                              |        | 30   | 60   |      |
| $t_{setup}$ Data setup time Parallel-In-Lines  | 5                               |        | 70   | 140  | ns   |
|  | 10                              |        | 25   | 50   |      |
|  | 15                              |        | 20   | 40   |      |

**Reset operation**

|                        |                        |    |     |     |    |
|------------------------|------------------------|----|-----|-----|----|
| $t_{PLH}$<br>$t_{PHL}$ | Propagation delay time | 5  | 230 | 460 | ns |
|                        |                        | 10 | 100 | 200 |    |
|                        |                        | 15 | 80  | 160 |    |
| $t_W$                  | Reset pulse width      | 5  | 125 | 250 | ns |
|                        |                        | 10 | 55  | 110 |    |
|                        |                        | 15 | 40  | 40  |    |

**LOGIC DIAGRAM**

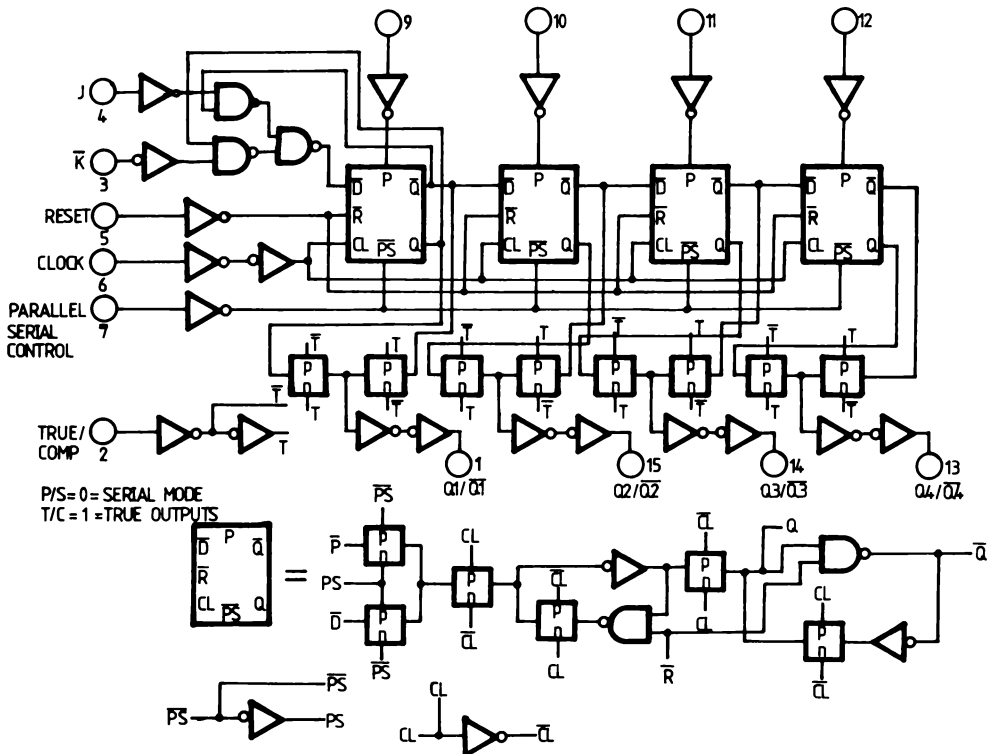

TYPICAL APPLICATIONS

Binary — to — BCD converter

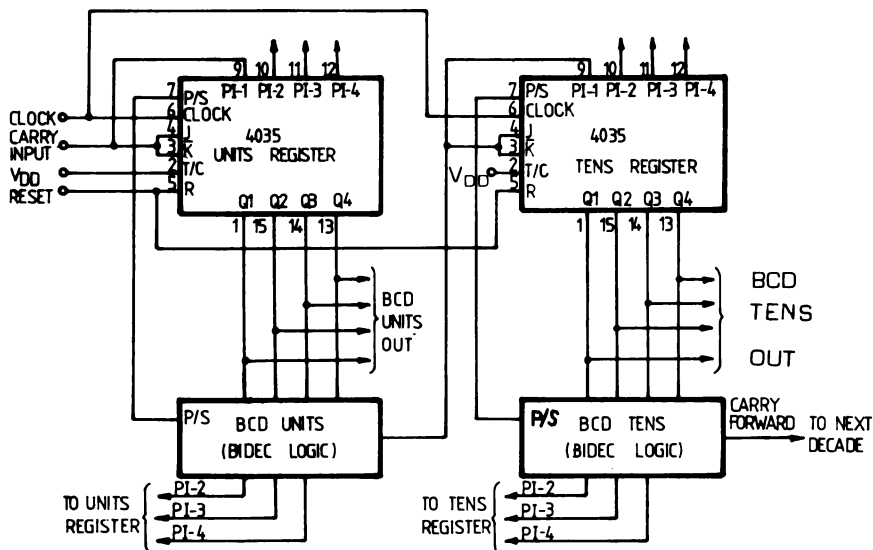

BIDEC logic

Double sequence generator

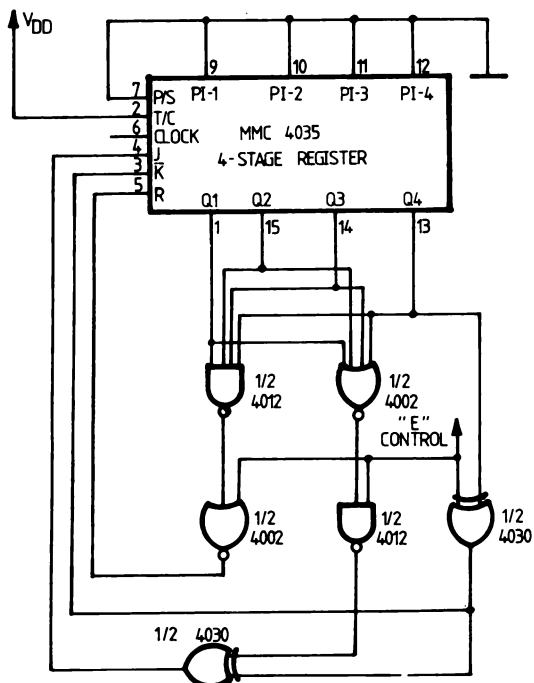
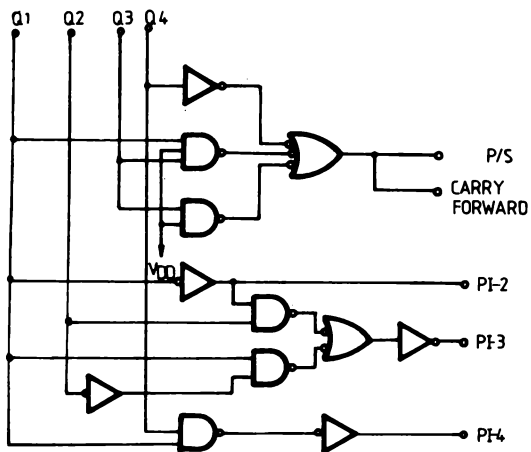

# QUAD TRUE/COMPLEMENT BUFFER

## GENERAL DESCRIPTION

The MMC 4041 is a monolithic integrated circuit processed in standard Al-gate CMOS technology. The MMC 4041 contains four true/complement buffers consisting of n- and p-channel units having low channel resistance and high current (sourcing and sinking) capability. The MMC 4041 is intended for use as a buffer, line driver, or CMOS-to-TTL driver. It can be used as an ultra-low power resistor-network driver for A/D and D/A conversion, as a transmission-line driver, and in other applications where high noise immunity and low-power dissipation are primary design requirements.

## FEATURES

- Balanced sink and source current; approximately 4 times standard „B“ drive
- Equalized delay to true and complement outputs

## ABSOLUTE MAXIMUM RATINGS

|            |  |  |                      |                |
|------------|--|--|----------------------|----------------|
| $V_{DD}^*$ | Supply voltage: G and H types<br>E and F types   | -0.5 to 20<br>-0.5 to 18<br>-0.5 to $V_{DD} + 0.5$ | 20<br>18<br>$\pm 10$ | V<br>V<br>mA   |
| $V_i$      | Input voltage  |  |                      | V              |
| $I_i$      | DC input current (any one input)   |  |                      | mA             |
| $P_{tot}$  | Total power dissipation (per package)<br>Dissipation per output transistor<br>for $T_A$ = full package-temperature range |  | 200                  | mW             |
| $T_A$      | Operating temperature : G and H types<br>E and F types   | -55 to -40 to -65 to                               | 125<br>85<br>150     | °C<br>°C<br>°C |
| $T_{stg}$  | Storage temperature  |  |                      | °C             |

\* All voltage values are referred to  $V_{SS}$  pin voltage

## RECOMMENDED OPERATING CONDITIONS

|            |  |                |                      |             |
|------------|--|----------------|----------------------|-------------|
| $V_{DD}^*$ | Supply voltage: G and H types<br>E and F types         | 3 to 3 to 0 to | 18<br>15<br>$V_{DD}$ | V<br>V<br>V |
| $V_i$      | Input voltage  |                |                      | V           |
| $T_A$      | Operating temperature : G and H types<br>E and F types | -55 to -40 to  | 125<br>85            | °C<br>°C    |

## CONNECTION DIAGRAM

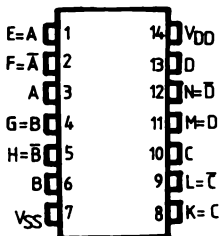

## FUNCTIONAL DIAGRAM

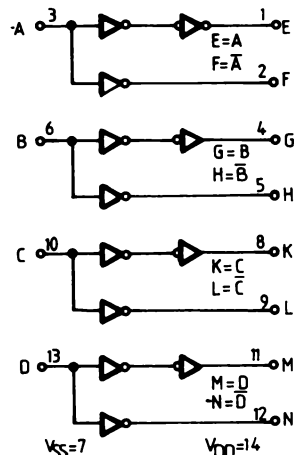

**STATIC ELECTRICAL CHARACTERISTICS**

(over recommended operating conditions)

| PARAMETER                         |                       | TEST CONDITIONS       |                       |                                |                        | VALUES           |       |           |       |            |                   | UNIT  |         |
|-----------------------------------|-----------------------|-----------------------|-----------------------|--------------------------------|------------------------|------------------|-------|-----------|-------|------------|-------------------|-------|---------|
|                                   |                       | V <sub>I</sub><br>(V) | V <sub>O</sub><br>(V) | I <sub>o</sub>  <br>( $\mu$ A) | V <sub>DD</sub><br>(V) | T <sub>LOW</sub> |       | 25°C      |       |            | T <sub>HIGH</sub> |       |         |
|                                   |                       |                       |                       |                                |                        | min.             | max.  | min.      | typ   | max.       | min.              |       | max.    |
| I <sub>L</sub>                    | Quiescent current     | G, H types            | 0/ 5                  |                                |                        | 5                |       | 1         |       | 0.02       | 1                 |       | 30      |
|                                   |                       |                       | 0/10                  |                                |                        | 10               |       | 2         |       | 0.02       | 2                 |       | 60      |
|                                   |                       |                       | 0/15                  |                                |                        | 15               |       | 4         |       | 0.02       | 4                 |       | 120     |
|                                   |                       |                       | 0/20                  |                                |                        | 20               |       | 20        |       | 0.04       | 20                |       | 600     |
|                                   | E, F types            | 0/ 5                  |                       |                                | 5                      |                  | 4     |           | 0.02  | 4          |                   | 30    |         |
|                                   |                       | 0/10                  |                       |                                | 10                     |                  | 8     |           | 0.02  | 8          |                   | 60    |         |
|                                   |                       | 0/15                  |                       |                                | 15                     |                  | 16    |           | 0.02  | 16         |                   | 120   |         |
| V <sub>OH</sub>                   | Output high voltage   | 0/ 5                  |                       | < 1                            | 5                      | 4.95             |       | 4.95      |       |            | 4.95              |       |         |
|                                   |                       | 0/10                  |                       | < 1                            | 10                     | 9.95             |       | 9.95      |       |            | 9.95              |       |         |
|                                   |                       | 0/15                  |                       | < 1                            | 15                     | 14.95            |       | 14.95     |       |            | 14.95             |       |         |
| V <sub>OL</sub>                   | Output low voltage    | 5 /0                  |                       | < 1                            | 5                      |                  |       |           |       | 0.05       |                   | 0.05  |         |
|                                   |                       | 10/0                  |                       | < 1                            | 10                     |                  |       |           |       | 0.05       |                   | 0.05  |         |
|                                   |                       | 15/0                  |                       | < 1                            | 15                     |                  |       |           |       | 0.05       |                   | 0.05  |         |
| V <sub>IH</sub>                   | Input high voltage    |                       | 0.5/4.5               | < 1                            | 5                      | 4                |       | 4         |       |            | 4                 |       |         |
|                                   |                       |                       | 1/9                   | < 1                            | 10                     | 8                |       | 8         |       |            | 8                 |       |         |
|                                   |                       |                       | 1.5/13.5              | < 1                            | 15                     | 12               |       | 12        |       |            | 13                |       |         |
| V <sub>IL</sub>                   | Input low voltage     |                       | 4.5/0.5               | < 1                            | 5                      |                  |       |           |       | 1.5        |                   | 1.5   |         |
|                                   |                       |                       | 9/1                   | < 1                            | 10                     |                  |       |           |       | 3          |                   | 3     |         |
|                                   |                       |                       | 13.5/1.5              | < 1                            | 15                     |                  |       |           |       | 4          |                   | 4     |         |
| I <sub>OH</sub>                   | Output drive current  | G, H types            | 0/ 5                  | 2.5                            |                        | 5                | -8.4  |           | -6.4  | -12.8      |                   | -4.6  |         |
|                                   |                       |                       | 0/ 5                  | 4.6                            |                        | 5                | -2.1  |           | -1.6  | -3.2       |                   | -1.2  |         |
|                                   |                       |                       | 0/10                  | 9.5                            |                        | 10               | -6.25 |           | -5    | -10        |                   | -3.5  |         |
|                                   |                       |                       | 0/15                  | 13.5                           |                        | 15               | -24   |           | -19   | -38        |                   | -13   |         |
|                                   |                       | E, F types            | 0/ 5                  | 2.5                            |                        | 5                | -6.8  |           | -5.44 | -12.8      |                   | -4.08 |         |
|                                   |                       |                       | 0/ 5                  | 4.6                            |                        | 5                | -1.7  |           | -1.36 | -3.2       |                   | -1.02 |         |
|                                   |                       | 0/10                  | 9.5                   |                                | 10                     | -5.31            |       | -4.25     | -10   |            | -3.18             |       |         |
|                                   |                       | 0/15                  | 13.5                  |                                | 15                     | -20.18           |       | -16.15    | -38   |            | -12.1             |       |         |
| I <sub>OL</sub>                   | Output sink current   | G, H types            | 0/ 5                  | 0.4                            |                        | 5                | 2.1   |           | 1.6   | 3.2        |                   | 1.2   |         |
|                                   |                       |                       | 0/10                  | 0.5                            |                        | 10               | 6.25  |           | 5     | 10         |                   | 3.5   |         |
|                                   |                       |                       | 0/15                  | 1.5                            |                        | 15               | 24    |           | 19    | 38         |                   | 13    |         |
|                                   |                       | E, F types            | 0/ 5                  | 0.4                            |                        | 5                | 1.7   |           | 1.36  | 3.2        |                   | 1.02  |         |
|                                   |                       |                       | 0/10                  | 0.5                            |                        | 10               | 5.31  |           | 4.25  | 10         |                   | 3.18  |         |
|                                   |                       |                       | 0/15                  | 1.5                            |                        | 15               | 20.18 |           | 16.15 | 38         |                   | 12.11 |         |
| I <sub>IH</sub> , I <sub>IL</sub> | Input leakage current | G, H types            | 0/18                  | Any input                      |                        | 18               |       | $\pm 0.1$ |       | $\pm 10^5$ | $\pm 0.1$         |       | $\pm 1$ |
|                                   |                       | E, F types            | 0/15                  |                                |                        | 15               |       | $\pm 0.3$ |       | $\pm 10^5$ | $\pm 0.3$         |       | $\pm 1$ |
| C <sub>I</sub>                    | Input capacitance     |                       | Any input             |                                |                        |                  |       |           | 5     | 7.5        |                   | pF    |         |

\* T<sub>LOW</sub> = -55°C for G, H devices; -40°C for E, F devices.

\* T<sub>HIGH</sub> = +125°C for G, H devices; +85°C for E, F devices.

The Noise Margin for both "1" and "0" level is:

1 V min. with V<sub>DD</sub> = 5 V

2 V min. with V<sub>DD</sub> = 10 V

2.5 V min. with V<sub>DD</sub> = 15 V

**DYNAMIC ELECTRICAL CHARACTERISTICS**

( $T_A = 25^\circ\text{C}$ ,  $C_L = 50\text{ pF}$ ,  $R_L = 200\text{ kohm}$ , typical temperature coefficient for all  $V_{DD}$  values is  $0.3\%/^\circ\text{C}$ , all input rise and fall times =  $20\text{ ns}$ )

| PARAMETER                                     | TEST CONDITIONS | VALUES |      |      | UNIT |
|---|-----------------|--------|------|------|------|
|   | VDD(V)          | min.   | typ. | max. |      |
| $t_{PLH}$ Propagation delay time<br>$t_{PHL}$ | 5               |        | 60   | 120  | ns   |
|   | 10              |        | 35   | 70   |      |
|   | 15              |        | 25   | 50   |      |
| $t_{THL}$ Transition time<br>$t_{THL}$        | 5               |        | 40   | 80   | ns   |
|   | 10              |        | 20   | 40   |      |
|   | 15              |        | 15   | 30   |      |

**SCHEMATIC DIAGRAM**

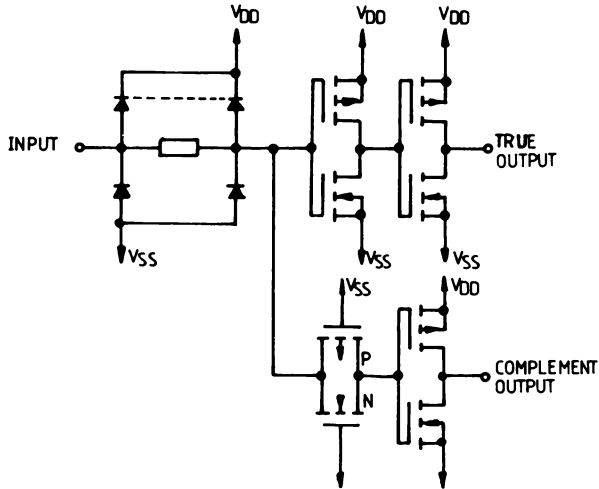

# QUAD CLOCKED „D“ LATCH

## GENERAL DESCRIPTION

The MMC 4042 is a monolithic integrated circuit, available in 16-lead dual in-line plastic package. The MMC 4042 contains four latch circuits, each strobed by a common clock. Complementary buffered outputs are available from each circuit.

Information present at the data input is transferred to outputs Q and  $\bar{Q}$  during the CLOCK level which is programmed by the POLARITY input. For POLARITY = 0 the transfer occurs during the 1 CLOCK level. The outputs follow the data input providing the CLOCK and POLARITY levels defined above are present. When a CLOCK transition occurs (positive for POLARITY = 0 and negative for POLARITY = 1) the information present at the input during the CLOCK transition is retained at the outputs until an opposite CLOCK transition occurs.

## FEATURES

- Medium-speed operation
- Fully static operation
- Low power TTL compatible
- Common CLOCK
- Buffered inputs and outputs

## ABSOLUTE MAXIMUM RATINGS

|            |  |  |                  |                |
|------------|--|--|------------------|----------------|
| $V_{DD}^*$ | Supply voltage: G and H types<br>E and F types   | -0.5 to 20<br>-0.5 to 18<br>-0.5 to $V_{DD}+0.5$ | 20<br>18<br>V    | V              |
| $V_i$      | Input voltage  |  | $V_{DD}+0.5$     | V              |
| $I_i$      | DC input current (any one input)   |  | $\pm 10$         | mA             |
| $P_{tot}$  | Total power dissipation (per package)<br>Dissipation per output transistor<br>for $T_A$ = full package-temperature range |  | 200<br>100       | mW<br>mW       |
| $T_A$      | Operating temperature : G and H types<br>E and F types   | -55 to -40 to -65 to                             | 125<br>85<br>150 | °C<br>°C<br>°C |
| $T_{stg}$  | Storage temperature  |  |                  |                |

\* All voltage values are referred to  $V_{SS}$  pin voltage

## RECOMMENDED OPERATING CONDITIONS

|            |  |                |                      |             |
|------------|--|----------------|----------------------|-------------|
| $V_{DD}^*$ | Supply voltage: G and H types<br>E and F types         | 3 to 3 to 0 to | 18<br>15<br>$V_{DD}$ | V<br>V<br>V |
| $V_i$      | Input voltage  |                |                      |             |
| $T_A$      | Operating temperature : G and H types<br>E and F types | -55 to -40 to  | 125<br>85            | °C<br>°C    |

## CONNECTION DIAGRAM

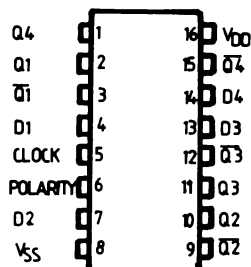

**STATIC ELECTRICAL CHARACTERISTICS**

(over recommended operating conditions)

| PARAMETER                         |                       | TEST CONDITIONS       |                       |                                |                        | VALUES             |       |           |       |                        |                     | UNIT  |         |         |
|-----------------------------------|-----------------------|-----------------------|-----------------------|--------------------------------|------------------------|--------------------|-------|-----------|-------|------------------------|---------------------|-------|---------|---------|
|                                   |                       | V <sub>I</sub><br>(V) | V <sub>O</sub><br>(V) | I <sub>O</sub>  <br>( $\mu$ A) | V <sub>DD</sub><br>(V) | T <sub>LOW</sub> * |       | 25°C      |       |                        | T <sub>HIGH</sub> * |       |         |         |
|                                   |                       |                       |                       |                                |                        | min.               | max.  | min.      | typ   | max.                   | min.                |       | max.    |         |
| I <sub>L</sub>                    | Quiescent current     | G, H types            | 0/ 5                  |                                |                        | 5                  |       | 1         |       | 0.02                   | 1                   |       | 30      |         |
|                                   |                       |                       | 0/10                  |                                |                        | 10                 |       | 2         |       | 0.02                   | 2                   |       | 60      |         |
|                                   |                       |                       | 0/15                  |                                |                        | 15                 |       | 4         |       | 0.02                   | 4                   |       | 120     |         |
|                                   |                       |                       | 0/20                  |                                |                        | 20                 |       | 20        |       | 0.04                   | 20                  |       | 600     |         |
|                                   |                       | E, F types            | 0/ 5                  |                                |                        | 5                  |       | 4         |       | 0.02                   | 4                   |       | 30      |         |
|                                   |                       |                       | 0/10                  |                                |                        | 10                 |       | 8         |       | 0.02                   | 8                   |       | 60      |         |
|                                   |                       |                       | 0/15                  |                                |                        | 15                 |       | 16        |       | 0.02                   | 16                  |       | 120     |         |
| V <sub>OH</sub>                   | Output high voltage   |                       | 0/ 5                  |                                | < 1                    | 5                  | 4.95  |           | 4.95  |                        |                     | 4.95  |         | V       |
|                                   |                       |                       | 0/10                  |                                | < 1                    | 10                 | 9.95  |           | 9.95  |                        |                     | 9.95  |         |         |
|                                   |                       |                       | 0/15                  |                                | < 1                    | 15                 | 14.95 |           | 14.95 |                        |                     | 14.95 |         |         |
| V <sub>OL</sub>                   | Output low voltage    |                       | 5 / 0                 |                                | < 1                    | 5                  |       |           |       |                        |                     | 0.05  |         | V       |
|                                   |                       |                       | 10/ 0                 |                                | < 1                    | 10                 |       |           |       |                        |                     | 0.05  |         |         |
|                                   |                       |                       | 15/ 0                 |                                | < 1                    | 15                 |       |           |       |                        |                     | 0.05  |         |         |
| V <sub>IH</sub>                   | Input high* voltage   |                       |                       | 0.5/4.5                        | < 1                    | 5                  | 3.5   |           | 3.5   |                        |                     | 3.5   |         | V       |
|                                   |                       |                       |                       | 1/9                            | < 1                    | 10                 | 7     |           | 7     |                        |                     | 7     |         |         |
|                                   |                       |                       |                       | 1.5/13.5                       | < 1                    | 15                 | 11    |           | 11    |                        |                     | 11    |         |         |
| V <sub>IL</sub>                   | Input low voltage     |                       |                       | 4.5/0.5                        | < 1                    | 5                  |       |           |       |                        |                     | 1.5   |         | V       |
|                                   |                       |                       |                       | 9/1                            | < 1                    | 10                 |       |           |       |                        |                     | 3     |         |         |
|                                   |                       |                       |                       | 13.5/1.5                       | < 1                    | 15                 |       |           |       |                        |                     | 4     |         |         |
| I <sub>OH</sub>                   | Output drive current  | G, H types            | 0/ 5                  | 2.5                            |                        | 5                  | -2    |           | -1.6  | -3.2                   |                     | -1.15 |         | mA      |
|                                   |                       |                       | 0/ 5                  | 4.6                            |                        | 5                  | -0.64 |           | -0.51 | -1                     |                     | -0.36 |         |         |
|                                   |                       |                       | 0/10                  | 9.5                            |                        | 10                 | -1.6  |           | -1.3  | -2.6                   |                     | -0.9  |         |         |
|                                   |                       |                       | 0/15                  | 13.5                           |                        | 15                 | -4.2  |           | -3.4  | -6.8                   |                     | -2.4  |         |         |
|                                   |                       | E, F types            | 0/ 5                  | 2.5                            |                        | 5                  | -1.53 |           | -1.36 | -3.2                   |                     | -1.1  |         | mA      |
|                                   |                       |                       | 0/ 5                  | 4.6                            |                        | 5                  | -0.52 |           | -0.44 | -1                     |                     | -0.36 |         |         |
|                                   |                       |                       | 0/10                  | 9.5                            |                        | 10                 | -1.3  |           | -1.1  | -2.6                   |                     | -0.9  |         |         |
|                                   |                       |                       | 0/15                  | 13.5                           |                        | 15                 | -3.6  |           | -3.0  | -6.8                   |                     | -2.4  |         |         |
| I <sub>OL</sub>                   | Output sink current   | G, H types            | 0/ 5                  | 0.4                            |                        | 5                  | 0.64  |           | 0.51  | 1                      |                     | 0.36  |         | mA      |
|                                   |                       |                       | 0/10                  | 0.5                            |                        | 10                 | 1.6   |           | 1.3   | 2.6                    |                     | 0.9   |         |         |
|                                   |                       |                       | 0/15                  | 1.5                            |                        | 15                 | 4.2   |           | 3.4   | 6.8                    |                     | 2.4   |         |         |
|                                   |                       | E, F types            | 0/ 5                  | 0.4                            |                        | 5                  | 0.52  |           | 0.44  | 1                      |                     | 0.36  |         | mA      |
|                                   |                       |                       | 0/10                  | 0.5                            |                        | 10                 | 1.3   |           | 1.1   | 2.6                    |                     | 0.9   |         |         |
|                                   |                       |                       | 0/15                  | 1.5                            |                        | 15                 | 3.6   |           | 3.0   | 6.8                    |                     | 2.4   |         |         |
| I <sub>IH</sub> , I <sub>IL</sub> | Input leakage current | G, H types            | 0/18                  | Any input                      |                        | 18                 |       | $\pm$ 0.1 |       | $\pm$ 10 <sup>-5</sup> | $\pm$ 0.1           |       | $\pm$ 1 | $\mu$ A |
|                                   |                       | E, F types            | 0/15                  |                                |                        | 15                 |       | $\pm$ 0.3 |       | $\pm$ 10 <sup>-5</sup> | $\pm$ 0.3           |       | $\pm$ 1 |         |
| C <sub>I</sub>                    | Input capacitance     |                       |                       | Any input                      |                        |                    |       |           |       | 5                      | 7.5                 |       |         | pF      |

\* T<sub>LOW</sub> = -55°C for G, H devices; -40°C for E, F devices.

\* T<sub>HIGH</sub> = +125°C for G, H devices; +85°C for E, F devices.

The Noise Margin for both "1" and "0" level is:

- 1 V min. with V<sub>DD</sub> = 5 V
- 2 V min. with V<sub>DD</sub> = 10 V
- 2.5 V min. with V<sub>DD</sub> = 15 V

**DYNAMIC ELECTRICAL CHARACTERISTICS**

( $T_A = 25^\circ\text{C}$ ,  $C_L = 50\text{ pF}$ ,  $R_L = 200\text{ k}$ , typical temperature coefficient for all  $V_{DD}$  values is  $0.3\%/^\circ\text{C}$ , all input rise and fall times =  $20\text{ ns}$ )

| PARAMETER                                       | TEST CONDITIONS<br>$V_{DD}(V)$ | VALUES                          |      |      | UNIT |
|---|--------------------------------|---------------------------------|------|------|------|
|   |                                | Min.                            | Typ. | Max. |      |
| $t_{PLH}$ , Propagation delay time<br>$t_{PHL}$ | Data In to Q                   | 5                               | 110  | 220  | ns   |
|   |                                | 10                              | 55   | 110  |      |
|   |                                | 15                              | 40   | 80   |      |
|   | Data In to $\bar{Q}$           | 5                               | 150  | 300  | ns   |
|   |                                | 10                              | 75   | 150  |      |
|   |                                | 15                              | 50   | 100  |      |
|   | Clock to Q                     | 5                               | 225  | 450  | ns   |
|   |                                | 10                              | 100  | 200  |      |
|   |                                | 15                              | 80   | 160  |      |
|   | Clock to $\bar{Q}$             | 5                               | 225  | 450  | ns   |
|   |                                | 10                              | 115  | 230  |      |
|   |                                | 15                              | 90   | 180  |      |
| $t_{THL}$ , Transition time<br>$t_{TLH}$        | 5                              | 100                             | 200  | ns   |      |
|   | 10                             | 50                              | 100  |      |      |
|   | 15                             | 40                              | 80   |      |      |
| $t_W$ , Clock pulse width                       | 5                              | 200                             | 100  | ns   |      |
|   | 10                             | 100                             | 50   |      |      |
|   | 15                             | 60                              | 30   |      |      |
| $t_{setup}$ , Setup time                        | 5                              | 50                              | 0    | ns   |      |
|   | 10                             | 30                              | 0    |      |      |
|   | 15                             | 25                              | 0    |      |      |
| $t_{hold}$ , Hold time                          | 5                              | 120                             | 60   | ns   |      |
|   | 10                             | 60                              | 30   |      |      |
|   | 15                             | 50                              | 25   |      |      |
| $t_r, t_f$ , Clock input rise and fall time     | 5                              | Not rise or fall time sensitive |      | ns   |      |
|   | 10                             |                                 |      |      |      |
|   | 15                             |                                 |      |      |      |

**LOGIC DIAGRAM**

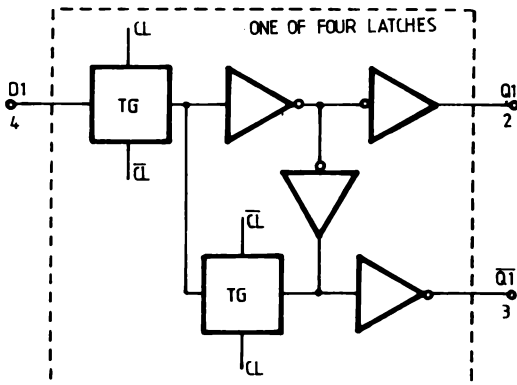

**TRUTH TABLE**

| CLOCK | POLARITY | Q     |
|-------|----------|-------|
| 0     | 0        | D     |
|       | 0        | LATCH |
| 1     | 1        | D     |
|       | 1        | LATCH |



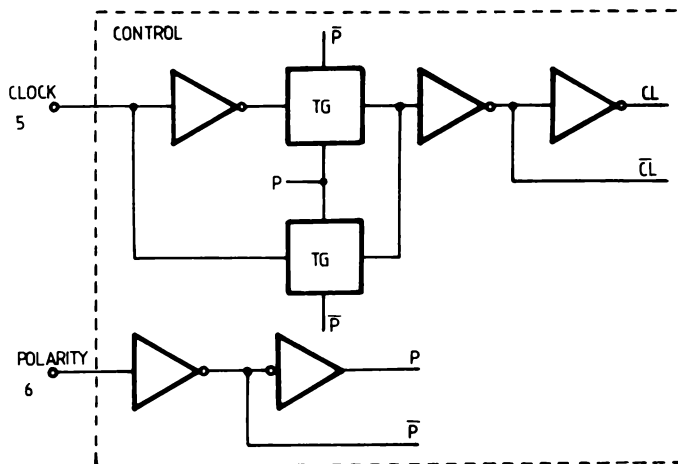

# QUAD 3-STATE R/S LATCHES: QUAD NOR R/S LATCH-MMC 4043 QUAD NAND R/S LATCH-MMC 4044

## GENERAL DESCRIPTION

The MMC 4043 types are quad cross-coupled 3-state COS/MOS NOR latches and MMC 4044 types are quad cross-coupled 3-state COS/MOS NAND latches. Each latch has a separate Q output and individual SET and RESET inputs. The Q outputs are controlled by a common ENABLE input. A logic „1“ or high on the ENABLE input connects the latch states to the Q outputs. A logic „0“ or low on the ENABLE input disconnects the latch states from the Q outputs, resulting in an open circuit condition on the Q outputs. The open circuit feature allows common busing of the outputs.

The MMC 4043 and MMC 4044 types are supplied in 16 — lead hermetic dual — in — line ceramic or plastic packages.

## FEATURES

- 3-state outputs with common output ENABLE
- Separate SET and RESET inputs for each latch
- NOR and NAND configurations

## APPLICATIONS

- Holding register in multi-register system
- Four-bits of independent storage with output enable
- Strobed register
- General digital logic

## ABSOLUTE MAXIMUM RATINGS

|            |  |  |  |
|------------|--|--|--|
| $V_{DD}^*$ | Supply voltage: G and H types<br>E and F types   | -0.5 to 20<br>-0.5 to 18<br>-0.5 to $V_{DD}+0.5$ | V<br>V<br>V                                    |
| $V_i$      | Input voltage  |  | V  |
| $I_i$      | DC input current (any one input)   |  | $\pm 10$ mA                                    |
| $P_{tot}$  | Total power dissipation (per package)<br>Dissipation per output transistor<br>for $T_A$ = full package-temperature range |  | 200 mW<br>100 mW                               |
| $T_A$      | Operating temperature :  | G and H types<br>E and F types                   | -55 to 125 °C<br>-40 to 85 °C<br>-65 to 150 °C |
| $T_{stg}$  | Storage temperature  |  |  |

\* All voltage values are referred to  $V_{SS}$  pin voltage

## RECOMMENDED OPERATING CONDITIONS

|            |  |                                     |                               |
|------------|--|-------------------------------------|-------------------------------|
| $V_{DD}^*$ | Supply voltage: G and H types<br>E and F types | 3 to 18<br>3 to 15<br>0 to $V_{DD}$ | V<br>V<br>V                   |
| $V_i$      | Input voltage                                  |                                     | V                             |
| $T_A$      | Operating temperature :                        | G and H types<br>E and F types      | -55 to 125 °C<br>-40 to 85 °C |

## CONNECTION DIAGRAM

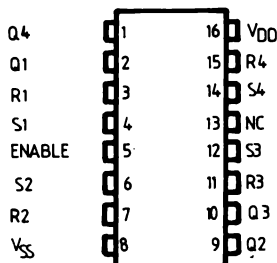
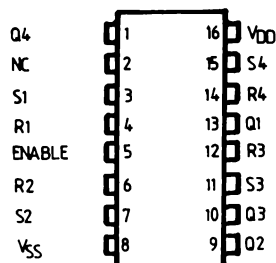
**MMC 4043**

**MMC 4044**

**STATIC ELECTRICAL CHARACTERISTICS**

(over recommended operating conditions)

| PARAMETER                         |                       | TEST CONDITIONS       |                       |                        |                        | VALUES           |       |      |       |                   |                   | UNIT  |      |    |
|-----------------------------------|-----------------------|-----------------------|-----------------------|------------------------|------------------------|------------------|-------|------|-------|-------------------|-------------------|-------|------|----|
|                                   |                       | V <sub>I</sub><br>(V) | V <sub>O</sub><br>(V) | I <sub>O</sub><br>(μA) | V <sub>DD</sub><br>(V) | T <sub>Low</sub> |       | 25°C |       |                   | T <sub>High</sub> |       |      |    |
|                                   |                       |                       |                       |                        |                        | min.             | max.  | min. | typ   | max.              | min.              |       | max. |    |
| I <sub>L</sub>                    | Quiescent current     | G, H types            | 0/ 5                  |                        |                        | 5                |       | 1    |       | 0.02              | 1                 |       | 30   |    |
|                                   |                       |                       | 0/10                  |                        |                        | 10               |       | 2    |       | 0.02              | 2                 |       | 60   |    |
|                                   |                       |                       | 0/15                  |                        |                        | 15               |       | 4    |       | 0.02              | 4                 |       | 120  |    |
|                                   |                       |                       | 0/20                  |                        |                        | 20               |       | 20   |       | 0.04              | 20                |       | 600  |    |
|                                   |                       | E, F types            | 0/ 5                  |                        |                        | 5                |       | 4    |       | 0.02              | 4                 |       | 30   |    |
|                                   |                       |                       | 0/10                  |                        |                        | 10               |       | 8    |       | 0.02              | 8                 |       | 60   |    |
|                                   |                       |                       | 0/15                  |                        |                        | 15               |       | 16   |       | 0.02              | 16                |       | 120  |    |
| V <sub>OH</sub>                   | Output high voltage   |                       | 0/ 5                  |                        | < 1                    | 5                | 4.95  |      | 4.95  |                   |                   | 4.95  |      | V  |
|                                   |                       |                       | 0/10                  |                        | < 1                    | 10               | 9.95  |      | 9.95  |                   |                   | 9.95  |      |    |
|                                   |                       |                       | 0/15                  |                        | < 1                    | 15               | 14.95 |      | 14.95 |                   |                   | 14.95 |      |    |
| V <sub>OL</sub>                   | Output low voltage    |                       | 5 / 0                 |                        | < 1                    | 5                |       | 0.05 |       |                   |                   | 0.05  |      | V  |
|                                   |                       |                       | 10 / 0                |                        | < 1                    | 10               |       | 0.05 |       |                   |                   | 0.05  |      |    |
|                                   |                       |                       | 15 / 0                |                        | < 1                    | 15               |       | 0.05 |       |                   |                   | 0.05  |      |    |
| V <sub>IH</sub>                   | Input high voltage    |                       |                       | 0.5/4.5                | < 1                    | 5                | 3.5   |      | 3.5   |                   |                   | 3.5   |      | V  |
|                                   |                       |                       |                       | 1/9                    | < 1                    | 10               | 7     |      | 7     |                   |                   | 7     |      |    |
|                                   |                       |                       |                       | 1.5/13.5               | < 1                    | 15               | 11    |      | 11    |                   |                   | 11    |      |    |
| V <sub>IL</sub>                   | Input low voltage     |                       |                       | 4.5/0.5                | < 1                    | 5                |       | 1.5  |       |                   | 1.5               |       | 1.5  | V  |
|                                   |                       |                       |                       | 9/1                    | < 1                    | 10               |       | 3    |       |                   | 3                 |       | 3    |    |
|                                   |                       |                       |                       | 13.5/1.5               | < 1                    | 15               |       | 4    |       |                   | 4                 |       | 4    |    |
| I <sub>OH</sub>                   | Output drive current  | G, H types            | 0/ 5                  | 2.5                    |                        | 5                | -2    |      | -1.6  | -3.2              |                   | -1.15 |      | mA |
|                                   |                       |                       | 0/ 5                  | 4.6                    |                        | 5                | -0.64 |      | -0.51 | -1                |                   | -0.36 |      |    |
|                                   |                       |                       | 0/10                  | 9.5                    |                        | 10               | -1.6  |      | -1.3  | -2.6              |                   | -0.9  |      |    |
|                                   |                       |                       | 0/15                  | 13.5                   |                        | 15               | -4.2  |      | -3.4  | -6.8              |                   | -2.4  |      |    |
|                                   |                       | E, F types            | 0/ 5                  | 2.5                    |                        | 5                | -1.53 |      | -1.36 | -3.2              |                   | -1.1  |      | mA |
|                                   |                       |                       | 0/ 5                  | 4.6                    |                        | 5                | -0.52 |      | -0.44 | -1                |                   | -0.36 |      |    |
|                                   |                       |                       | 0/10                  | 9.5                    |                        | 10               | -1.3  |      | -1.1  | -2.6              |                   | -0.9  |      |    |
|                                   |                       |                       | 0/15                  | 13.5                   |                        | 15               | -3.6  |      | -3.0  | -6.8              |                   | -2.4  |      |    |
| I <sub>OL</sub>                   | Output sink current   | G, H types            | 0/ 5                  | 0.4                    |                        | 5                | 0.64  |      | 0.51  | 1                 |                   | 0.36  |      | mA |
|                                   |                       |                       | 0/10                  | 0.5                    |                        | 10               | 1.6   |      | 1.3   | 2.6               |                   | 0.9   |      |    |
|                                   |                       |                       | 0/15                  | 1.5                    |                        | 15               | 4.2   |      | 3.4   | 6.8               |                   | 2.4   |      |    |
|                                   |                       | E, F types            | 0/ 5                  | 0.4                    |                        | 5                | 0.52  |      | 0.44  | 1                 |                   | 0.36  |      | mA |
|                                   |                       |                       | 0/10                  | 0.5                    |                        | 10               | 1.3   |      | 1.1   | 2.6               |                   | 0.9   |      |    |
|                                   |                       |                       | 0/15                  | 1.5                    |                        | 15               | 3.6   |      | 3.0   | 6.8               |                   | 2.4   |      |    |
| I <sub>IH</sub> , I <sub>IL</sub> | Input leakage current | G, H types            | 0/18                  | Any input              |                        | 18               |       | ±0.1 |       | ±10 <sup>-5</sup> | ±0.1              |       | ±1   | μA |
|                                   |                       |                       |                       |                        |                        |                  | 15    |      | ±0.3  |                   | ±10 <sup>-5</sup> | ±0.3  |      |    |
|                                   |                       | E, F types            | 0/15                  |                        |                        | 15               |       | ±0.3 |       | ±10 <sup>-5</sup> | ±0.3              |       | ±1   |    |
| I <sub>OH</sub>                   | 3—state output        | G, H types            | 0/18                  | 0/18                   |                        | 18               |       | ±0.4 |       | ±10 <sup>-4</sup> | ±0.4              |       | ±12  | μA |
|                                   |                       |                       |                       |                        |                        | 15               |       | ±1.0 |       | ±10 <sup>-4</sup> | ±1.0              |       | ±7.5 |    |
|                                   |                       | E, F types            | 0/15                  | 0/15                   |                        | 15               |       | ±1.0 |       | ±10 <sup>-4</sup> | ±1.0              |       | ±7.5 |    |

| PARAMETER                        | TEST CONDITIONS       |                       |                          |                        | VALUES            |      |      |      |      |                    | UNIT |      |
|----------------------------------|-----------------------|-----------------------|--------------------------|------------------------|-------------------|------|------|------|------|--------------------|------|------|
|                                  | V <sub>I</sub><br>(V) | V <sub>O</sub><br>(V) | I <sub>O</sub>  <br>(μA) | V <sub>DD</sub><br>(V) | T* <sub>LOW</sub> |      | 25°C |      |      | T* <sub>HIGH</sub> |      |      |
|                                  |                       |                       |                          |                        | min.              | max. | min. | typ. | max. | min.               |      | max. |
| C <sub>i</sub> Input capacitance | Any input             |                       |                          |                        |                   |      |      | 5    | 7.5  |                    |      | pF   |

- T<sub>LOW</sub> = -55°C for G, H devices; -40°C for E, F devices.
  - T<sub>HIGH</sub> = +125°C for G, H devices; +85°C for E, F devices.
- The Noise Margin for both "1" and "0" level is:
- 1 V min. with V<sub>DD</sub> = 5 V
  - 2 V min. with V<sub>DD</sub> = 10 V
  - 2.5 V min. with V<sub>DD</sub> = 15 V

**DYNAMIC ELECTRICAL CHARACTERISTICS**

(T<sub>A</sub> = 25°C, input t<sub>r</sub>, t<sub>r</sub> = 20ns, C<sub>L</sub> = 50 pF, R<sub>L</sub> = 200 kΩ)

| PARAMETER   | V <sub>DD</sub><br>(V) | VALUES          |                   | UNITS |
|---|------------------------|-----------------|-------------------|-------|
|   |                        | typ.            | max.              |       |
| t <sub>PLH</sub><br>t <sub>PHL</sub> Propagation delay time (SET or RESET to Q)   | 5<br>10<br>15          | 150<br>70<br>50 | 300<br>140<br>100 | ns    |
| t <sub>PZH</sub><br>t <sub>PZH</sub> 3-state propagation delay time (ENABLE to Q) | 5<br>10<br>15          | 115<br>55<br>40 | 230<br>110<br>80  | ns    |
| t <sub>PLZ</sub><br>t <sub>PZL</sub> 3-state propagation delay time               | 5<br>10<br>15          | 90<br>50<br>35  | 180<br>100<br>70  | ns    |
| t <sub>THL</sub><br>t <sub>TLH</sub> Transition time                              | 5<br>10<br>15          | 100<br>50<br>40 | 200<br>100<br>80  | ns    |
| t <sub>w</sub> SET or RESET pulse width   | 5<br>10<br>15          | 80<br>40<br>20  | 160<br>80<br>40   | ns    |

**LOGIC DIAGRAMS**

**MMC 4043**

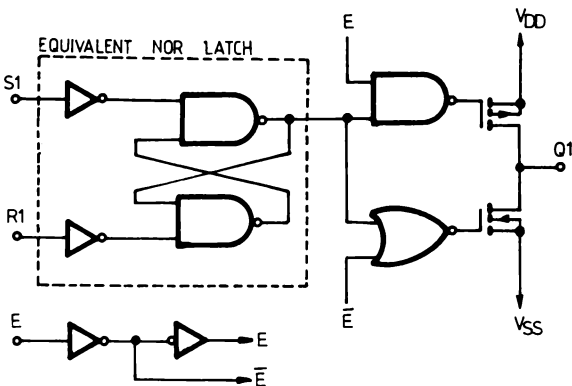

**MMC 4044**

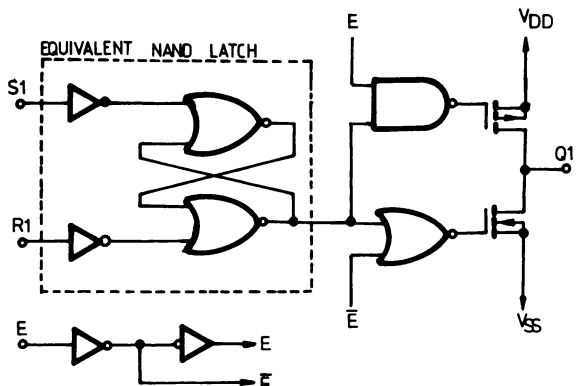

TEST CIRCUITS

ENABLE propagation delay time and waveforms

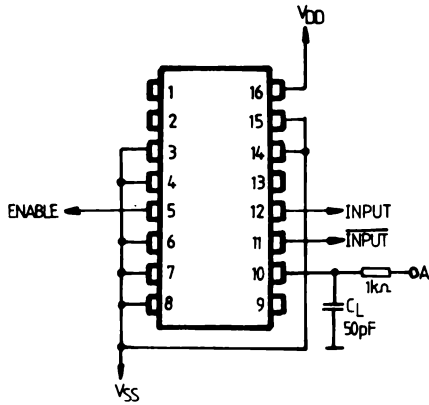

| TEST      | IN       | IN       | A        |
|-----------|----------|----------|----------|
| $t_{PHZ}$ | $V_{DD}$ | $V_{SS}$ | $V_{SS}$ |
| $t_{PLZ}$ | $V_{SS}$ | $V_{DD}$ | $V_{DD}$ |
| $t_{PZH}$ | $V_{DD}$ | $V_{SS}$ | $V_{SS}$ |
| $t_{PZL}$ | $V_{SS}$ | $V_{DD}$ | $V_{DD}$ |

Z = HIGH IMPEDANCE

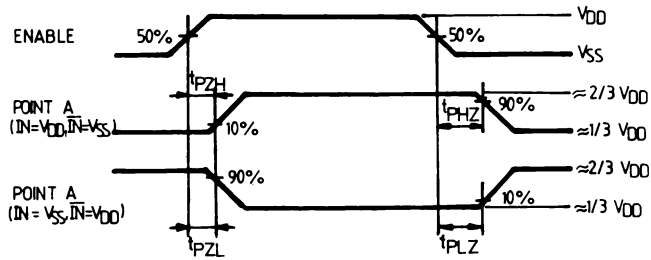

# LOW-POWER MONOSTABLE/ ASTABLE MULTIVIBRATOR

## GENERAL DESCRIPTION

The MMC 4047 is a monolithic integrated circuit processed in standard Al-gate CMOS technology available in 14 lead dual in-line package. The MMC 4047 consists of a gatable astable multivibrator with logic techniques incorporated to permit positive or negative edge-triggered monostable multivibrator action with retriggering and external counting options. Inputs include +TRIGGER, -TRIGGER,

ASTABLE, ASTABLE, RETRIGGER and EXTERNAL RESET. Buffered outputs are Q,  $\bar{Q}$  and OSCILLATOR. In all modes of operation, an external capacitor must be connected between C-Timing and C-Common terminals, and an external resistor must be connected between the R-Timing and RC-Common terminals.

## FEATURES

- Low-power consumption: special CMOS oscillator configuration
- Monostable (one-shot) or astable (free-running) operation
- True and complemented buffered outputs
- Only one external R and C required
- Buffered inputs

## ABSOLUTE MAXIMUM RATINGS

|            |  |                               |                            |                |
|------------|--|-------------------------------|----------------------------|----------------|
| $V_{DD}^*$ | Supply voltage: G and H types<br>E and F types   | -0.5 to<br>-0.5 to<br>-0.5 to | 20<br>18<br>$V_{DD} + 0.5$ | V<br>V<br>V    |
| $V_i$      | Input voltage  |                               |                            | V              |
| $I_i$      | DC input current (any one input)   |                               | $\pm 10$                   | mA             |
| $P_{tot}$  | Total power dissipation (per package)<br>Dissipation per output transistor<br>for $T_A$ = full package-temperature range |                               | 200                        | mW             |
| $T_A$      | Operating temperature : G and H types<br>E and F types   | -55 to<br>40 to<br>-65 to     | 125<br>85<br>150           | °C<br>°C<br>°C |
| $T_{stg}$  | Storage temperature  |                               |                            | °C             |

\* All voltage values are referred to  $V_{SS}$  pin voltage

## RECOMMENDED OPERATING CONDITIONS

|            |  |                      |                      |             |
|------------|--|----------------------|----------------------|-------------|
| $V_{DD}^*$ | Supply voltage: G and H types<br>E and F types         | 3 to<br>3 to<br>0 to | 18<br>15<br>$V_{DD}$ | V<br>V<br>V |
| $V_i$      | Input voltage  |                      |                      | V           |
| $T_A$      | Operating temperature : G and H types<br>E and F types | -55 to<br>-40 to     | 125<br>85            | °C<br>°C    |

## CONNECTION DIAGRAM

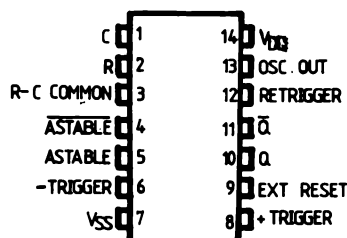

LOGIC DIAGRAM

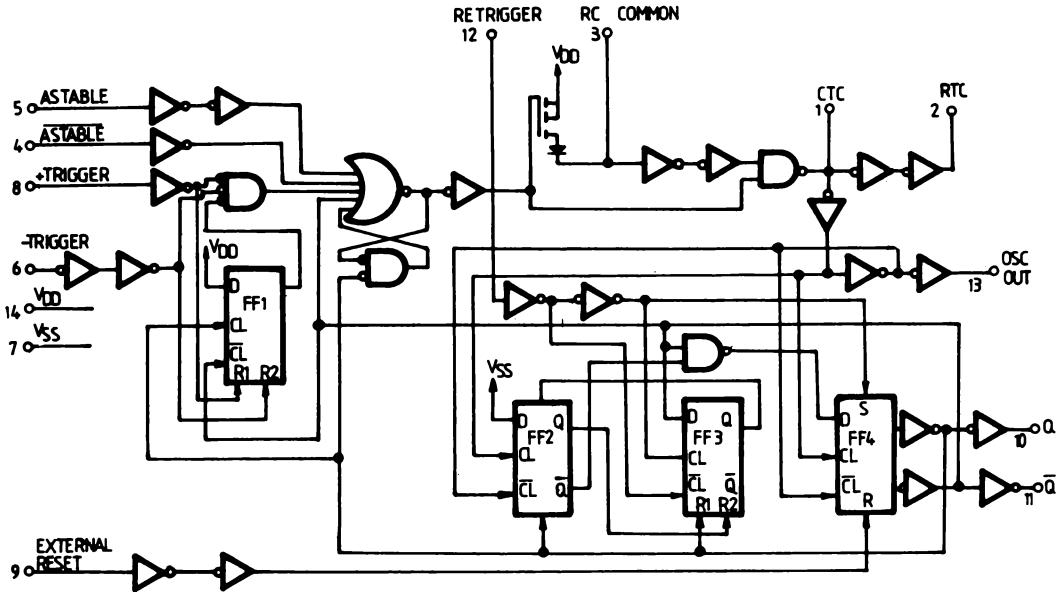

FUNCTIONAL TERMINAL CONNECTIONS

| FUNCTION*                 | TERMINAL CONNECTIONS |                    |                | OUTPUT PULSE FROM | OUTPUT PERIOD OR PULSE WIDTH |
|---------------------------|----------------------|--------------------|----------------|-------------------|------------------------------|
|                           | TO V <sub>DD</sub>   | TO V <sub>SS</sub> | INPUT PULSE TO |                   |                              |
| Astable multivibrator:    |                      |                    |                |                   |                              |
| Free running              | 4, 5, 6, 14          | 7, 8, 9, 12        | —              | 10, 11, 13        | $t_A(10, 11)=4.40 RC$        |
| True gating               | 4, 6, 14             | 7, 8, 9, 12        | 5              | 10, 11, 13        | $t_A(13)=2.20 RC$            |
| Complement gating         | 6, 14                | 5, 7, 8, 9, 12     | 4              | 10, 11, 13        |                              |
| Monostable multivibrator: |                      |                    |                |                   |                              |
| Positive-edge trigger     | 4, 14                | 5, 6, 7, 9, 12     | 8              | 10, 11            |                              |
| Negative-edge trigger     | 4, 8, 14             | 5, 7, 9, 12        | 6              | 10, 11            |                              |
| Retriggerable             | 4, 14                | 5, 6, 7, 9         | 8, 12          | 10, 11            |                              |
| External countdown**      | 14                   | 5, 6, 7, 8, 9, 12  | —              | 10, 11            | $t_M(10, 11)=2.48 RC$        |

\* In all cases external capacitor and resistor between pins 1, 2 and 3 (see logic diagrams)

\*\* Input pulse to reset of external counting chip.

External counting chip output to pin 4

**STATIC ELECTRICAL CHARACTERISTICS**

(over recommended operating conditions)

| PARAMETER                         |                       | TEST CONDITIONS       |                       |                                |                        | VALUES             |       |           |       |                        |                     | UNIT  |         |         |
|-----------------------------------|-----------------------|-----------------------|-----------------------|--------------------------------|------------------------|--------------------|-------|-----------|-------|------------------------|---------------------|-------|---------|---------|
|                                   |                       | V <sub>I</sub><br>(V) | V <sub>O</sub><br>(V) | I <sub>O</sub>  <br>( $\mu$ A) | V <sub>DD</sub><br>(V) | T <sub>LOW</sub> * |       | 25°C      |       |                        | T <sub>HIGH</sub> * |       |         |         |
|                                   |                       |                       |                       |                                |                        | min.               | max.  | min.      | typ   | max.                   | min.                |       | max.    |         |
| I <sub>L</sub>                    | Quiescent current     | G, H types            | 0/ 5                  |                                |                        | 5                  |       | 1         |       | 0.02                   | 1                   |       | 30      |         |
|                                   |                       |                       | 0/10                  |                                |                        | 10                 |       | 2         |       | 0.02                   | 2                   |       | 60      |         |
|                                   |                       |                       | 0/15                  |                                |                        | 15                 |       | 4         |       | 0.02                   | 4                   |       | 120     |         |
|                                   |                       |                       | 0/20                  |                                |                        | 20                 |       | 20        |       | 0.04                   | 20                  |       | 600     |         |
|                                   |                       | E, F types            | 0/ 5                  |                                |                        | 5                  |       | 4         |       | 0.02                   | 4                   |       | 30      |         |
|                                   |                       |                       | 0/10                  |                                |                        | 10                 |       | 8         |       | 0.02                   | 8                   |       | 60      |         |
|                                   |                       |                       | 0/15                  |                                |                        | 15                 |       | 16        |       | 0.02                   | 16                  |       | 120     |         |
| V <sub>OH</sub>                   | Output high voltage   |                       | 0/ 5                  |                                | < 1                    | 5                  | 4.95  |           | 4.95  |                        |                     | 4.95  |         | V       |
|                                   |                       |                       | 0/10                  |                                | < 1                    | 10                 | 9.95  |           | 9.95  |                        |                     | 9.95  |         |         |
|                                   |                       |                       | 0/15                  |                                | < 1                    | 15                 | 14.95 |           | 14.95 |                        |                     | 14.95 |         |         |
| V <sub>OL</sub>                   | Output low voltage    |                       | 5 /0                  |                                | < 1                    | 5                  |       | 0.05      |       |                        | 0.05                |       | 0.05    | V       |
|                                   |                       |                       | 10/0                  |                                | < 1                    | 10                 |       | 0.05      |       |                        | 0.05                |       | 0.05    |         |
|                                   |                       |                       | 15/0                  |                                | < 1                    | 15                 |       | 0.05      |       |                        | 0.05                |       | 0.05    |         |
| V <sub>IH</sub>                   | Input high voltage    |                       | 0.5/4.5               |                                | < 1                    | 5                  | 3.5   |           | 3.5   |                        |                     | 3.5   |         | V       |
|                                   |                       |                       | 1/9                   |                                | < 1                    | 10                 | 7     |           | 7     |                        |                     | 7     |         |         |
|                                   |                       |                       | 1.5/13.5              |                                | < 1                    | 15                 | 11    |           | 11    |                        |                     | 11    |         |         |
| V <sub>IL</sub>                   | Input low voltage     |                       | 4.5/0.5               |                                | < 1                    | 5                  |       | 1.5       |       |                        | 1.5                 |       | 1.5     | V       |
|                                   |                       |                       | 9/1                   |                                | < 1                    | 10                 |       | 3         |       |                        | 3                   |       | 3       |         |
|                                   |                       |                       | 13.5/1.5              |                                | < 1                    | 15                 |       | 4         |       |                        | 4                   |       | 4       |         |
| I <sub>OH</sub>                   | Output drive current  | G, H types            | 0/ 5                  | 2.5                            |                        | 5                  | -2    |           | -1.6  | -3.2                   |                     | -1.15 |         | mA      |
|                                   |                       |                       | 0/ 5                  | 4.6                            |                        | 5                  | -0.64 |           | -0.51 | -1                     |                     | -0.36 |         |         |
|                                   |                       |                       | 0/10                  | 9.5                            |                        | 10                 | -1.6  |           | -1.3  | -2.6                   |                     | -0.9  |         |         |
|                                   |                       |                       | 0/15                  | 13.5                           |                        | 15                 | -4.2  |           | -3.4  | -6.8                   |                     | -2.4  |         |         |
|                                   |                       | E, F types            | 0/ 5                  | 2.5                            |                        | 5                  | -1.53 |           | -1.36 | -3.2                   |                     | -1.1  |         | mA      |
|                                   |                       |                       | 0/ 5                  | 4.6                            |                        | 5                  | -0.52 |           | -0.44 | -1                     |                     | -0.36 |         |         |
|                                   |                       |                       | 0/10                  | 9.5                            |                        | 10                 | -1.3  |           | -1.1  | -2.6                   |                     | -0.9  |         |         |
|                                   |                       |                       | 0/15                  | 13.5                           |                        | 15                 | -3.6  |           | -3.0  | -6.8                   |                     | -2.4  |         |         |
| I <sub>OL</sub>                   | Output sink current   | G, H types            | 0/ 5                  | 0.4                            |                        | 5                  | 0.64  |           | 0.51  | 1                      |                     | 0.36  |         | mA      |
|                                   |                       |                       | 0/10                  | 0.5                            |                        | 10                 | 1.6   |           | 1.3   | 2.6                    |                     | 0.9   |         |         |
|                                   |                       |                       | 0/15                  | 1.5                            |                        | 15                 | 4.2   |           | 3.4   | 6.8                    |                     | 2.4   |         |         |
|                                   |                       | E, F types            | 0/ 5                  | 0.4                            |                        | 5                  | 0.52  |           | 0.44  | 1                      |                     | 0.36  |         | mA      |
|                                   |                       |                       | 0/10                  | 0.5                            |                        | 10                 | 1.3   |           | 1.1   | 2.6                    |                     | 0.9   |         |         |
|                                   |                       |                       | 0/15                  | 1.5                            |                        | 15                 | 3.6   |           | 3.0   | 6.8                    |                     | 2.4   |         |         |
| I <sub>IH</sub> , I <sub>IL</sub> | Input leakage current | G, H types            | 0/18                  | Any input                      |                        | 18                 |       | $\pm$ 0.1 |       | $\pm$ 10 <sup>-5</sup> | $\pm$ 0.1           |       | $\pm$ 1 | $\mu$ A |
|                                   |                       |                       |                       |                                |                        |                    |       |           |       |                        |                     |       |         |         |
|                                   |                       | E, F types            | 0/15                  |                                |                        | 15                 |       | $\pm$ 0.3 |       | $\pm$ 10 <sup>-5</sup> | $\pm$ 0.3           |       | $\pm$ 1 |         |
| C <sub>I</sub>                    | Input capacitance     |                       |                       | Any input                      |                        |                    |       |           |       | 5                      | 7.5                 |       |         | pF      |

\* T<sub>LOW</sub> = -55°C for G, H devices; -40°C for E, F devices.

\* T<sub>HIGH</sub> = +125°C for G, H devices; +85°C for E, F devices.

The Noise Margin for both "1" and "0" level is:

- 1 V min. with V<sub>DD</sub> = 5 V
- 2 V min. with V<sub>DD</sub> = 10 V
- 2.5 V min. with V<sub>DD</sub> = 15 V



**DYNAMIC ELECTRICAL CHARACTERISTICS**

( $T_A = 25^\circ\text{C}$ ,  $C_L = 15\text{ pF}$ ,  $R_L = 200\text{ kohm}$ , typical temperature coefficient for all  $V_{DD}$  values is  $0.3\%/^\circ\text{C}$ , all input rise and fall times =  $20\text{ ns}$ )

| PARAMETER                          |  |  | TEST CONDITIONS<br>$V_{DD}$ (V) | VALUES    |           |               | UNIT |
|------------------------------------|--|--|---------------------------------|-----------|-----------|---------------|------|
|                                    |  |  |                                 | min.      | typ.      | max.          |      |
| $t_{PLH}$<br>$t_{PHL}$             | Propagation delay time                     | Astable, $\overline{\text{Astable}}$<br>to osc. out          | 5                               | 200       | 400       | ns            |      |
|                                    |  |  | 10                              | 100       | 200       |               |      |
|                                    |  |  | 15                              | 80        | 160       |               |      |
|                                    |  | Astable, $\overline{\text{Astable}}$<br>to Q, $\overline{Q}$ | 5                               | 350       | 700       | ns            |      |
|                                    |  |  | 10                              | 175       | 350       |               |      |
|                                    |  |  | 15                              | 125       | 250       |               |      |
|                                    |  | + or - Trigger to<br>Q, $\overline{Q}$                       | 5                               | 500       | 1000      | ns            |      |
|                                    |  |  | 10                              | 225       | 450       |               |      |
|                                    |  |  | 15                              | 150       | 300       |               |      |
|                                    |  | Retrigger to<br>Q, $\overline{Q}$                            | 5                               | 300       | 600       | ns            |      |
|                                    |  |  | 10                              | 150       | 300       |               |      |
|                                    |  |  | 15                              | 100       | 200       |               |      |
|                                    |  | External Reset<br>to Q, $\overline{Q}$                       | 5                               | 250       | 500       | ns            |      |
|                                    |  |  | 10                              | 100       | 200       |               |      |
|                                    |  |  | 15                              | 70        | 140       |               |      |
| $t_{THL}$<br>$t_{TLH}$             | Transition time osc. out Q, $\overline{Q}$ |  | 5                               | 100       | 200       | ns            |      |
|                                    |  |  | 10                              | 50        | 100       |               |      |
|                                    |  |  | 15                              | 40        | 80        |               |      |
| $t_W$                              | Input pulse width:                         | +Trigger,  | 5                               | 200       | 400       | ns            |      |
|                                    |  | -Trigger   | 10                              | 80        | 160       |               |      |
|                                    |  |  | 15                              | 50        | 100       |               |      |
|                                    | Reset                                      |  | 5                               | 100       | 200       | ns            |      |
|                                    |  |  | 10                              | 50        | 100       |               |      |
|                                    |  |  | 15                              | 30        | 60        |               |      |
| Retrigger                          |  | 5  | 300                             | 600       | ns        |               |      |
|                                    |  | 10   | 115                             | 230       |           |               |      |
|                                    |  | 15   | 75                              | 150       |           |               |      |
| $t_r$ , $t_f$                      | Input rise and fall time<br>All inputs     |  | 5                               | Unlimited |           | $\mu\text{s}$ |      |
|                                    |  |  | 10                              |           |           |               |      |
|                                    |  |  | 15                              |           |           |               |      |
| Q or $\overline{Q}$<br>Duty factor | deviation from 50%<br>Duty factor          |  | 5                               | $\pm 0.5$ | $\pm 1$   | $\%$          |      |
|                                    |  |  | 10                              | $\pm 0.5$ | $\pm 1$   |               |      |
|                                    |  |  | 15                              | $\pm 0.1$ | $\pm 0.5$ |               |      |

**APPLICATION INFORMATION**

**1 - Circuit description**

Astable operation is enabled by a high level on the ASTABLE input. The period of the square wave at the Q and  $\overline{Q}$  Outputs in this mode of operation is a function of the external components employed. „True“ input pulses on the ASTABLE input or „Complement“ pulses on the  $\overline{\text{ASTABLE}}$  input allow the circuit to be used as a gatable multivibrator. The OSCILLATOR output period will be half of the Q terminal output in the astable mode. However, a 50% duty cycle is not guaranteed at this output. In the monostable mode, positive-edge triggering is accomplished by application of a leading-edge pulse to the +TRIGGER input and a low level to the -TRIGGER input. For negative-edge triggering, a trailing-edge pulse is applied to the -TRIGGER and a high level is applied to the +TRIGGER. Input pulses may be of any duration relative to the output pulse.

The multivibrator can be retriggered (on the leading edge only) by applying a common pulse to both the RE-TRIGGER and +TRIGGER inputs. In this mode the output pulse remains high as long as the input pulse period is shorter than the period determined by the RC components. An external countdown option can be implemented by coupling „G” to an external „N” counter and resetting the counter with the trigger pulse. The

counter output pulse is fed back to the ASTABLE input and has a duration equal to N times the period of the multivibrator. A high level on the EXTERNAL RESET input assures no output pulse during an „ON” power condition. This input can also be activated to terminate the output pulse at any time. In the monostable mode, high-level or power-on reset pulse, must be applied to the EXTERNAL RESET whenever V<sub>DD</sub> is applied.

**2 - Astable Mode**

The following analysis presents worst-case variations from unit-to-unit as a function of transfer-voltage (V<sub>TR</sub>) shift (33%–67% V<sub>DD</sub>) for free-running (astable) operation.

Astable mode waveforms

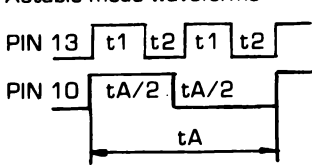

$$t1 = - RC \ln \frac{V_{TR}}{V_{DD} + V_{TR}}$$

$$t2 = - RC \ln \frac{V_{DD} - V_{TR}}{2V_{DD} - V_{TR}}$$

$$t_A = 2(t1 + t2) = -2RC \ln \frac{(V_{TR})(V_{DD} - V_{TR})}{(V_{DD} - V_{TR})(2V_{DD} - V_{TR})}$$

- Typ: V<sub>TR</sub> = 0.5 V<sub>DD</sub>      t<sub>A</sub> = 4.40 RC
- Min: V<sub>TR</sub> = 0.33 V<sub>DD</sub>    t<sub>A</sub> = 4.62 RC
- Max: V<sub>TR</sub> = 0.67 V<sub>DD</sub>    t<sub>A</sub> = 4.62 RC

thus if t<sub>A</sub> = 4.40 RC is used, the maximum variation will be (+5.0%, - 0.0%) In addition to variations from unit-to-unit, the astable period may vary as a function of frequency with respect to V<sub>DD</sub> and temperature.

**3 - Monostable Mode**

The following analysis presents worst-case variations from unit-to-unit as a function of transfer-voltage (V<sub>TR</sub>) shift (33%–67% V<sub>DD</sub>) for one-shot (monostable) operation.

Monostable waveforms

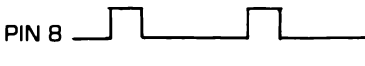

$$t1 = - RC \ln \frac{V_{TR}}{V_{DD} + V_{DD}}$$

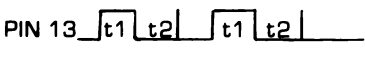

$$t2 = - RC \ln \frac{V_{DD} - V_{TR}}{2V_{DD} - V_{TR}}$$



$$tM = (t1 + t2) = - RC \ln \frac{(V_{TR})(V_{DD} - V_{TR})}{(2V_{DD} - V_{TR})(2V_{DD})}$$

where t<sub>M</sub> = monostable mode pulse width. Values for t<sub>M</sub> are as follows:

- Typ: V<sub>TR</sub> = 0.5 V<sub>DD</sub>      t<sub>M</sub> = 2.48 RC
- Min: V<sub>TR</sub> = 0.33 V<sub>DD</sub>    t<sub>M</sub> = 2.71 RC
- Max: V<sub>TR</sub> = 0.67 V<sub>DD</sub>    t<sub>M</sub> = 2.48 RC

Thus if t<sub>M</sub> = 2.48 RC is used, the maximum variation will be (+9.3% - 0.0%)

Note: In the astable mode the first positive half cycle has a duration of T<sub>M</sub>; succeeding durations are t<sub>A</sub>/2. In addition to variations from unit-to-unit, the monostable pulse width may vary as a function of frequency with respect to V<sub>DD</sub> and temperature.

**4 - Retrigger mode**

The MMC 4047 can be used in the retrigger mode to extend the output-pulse duration, or to compare the frequency of an input signal with that of the internal oscillator. In the retrigger mode the input pulse is applied to terminals 8 and 12, and the output is taken from terminal 10 or 11. As shown in Fig. A normal monostable action is obtained when one retrigger pulse is applied. For two input pulses, t<sub>RE</sub> = t<sub>1</sub> + t<sub>1</sub> + 2t<sub>2</sub>.

For more than two pulses,  $t_{RE}(Q \text{ OUTPUT})$  terminates at some variable time  $t_D$  after the termination of the last retrigger pulse.  $t_D$  is variable because  $t_{RE}(Q \text{ OUTPUT})$  terminates after the second positive edge of the oscillator output appears at flip-flop 4 (see logic diagram).

Fig. A' Retrigger-mode waveforms

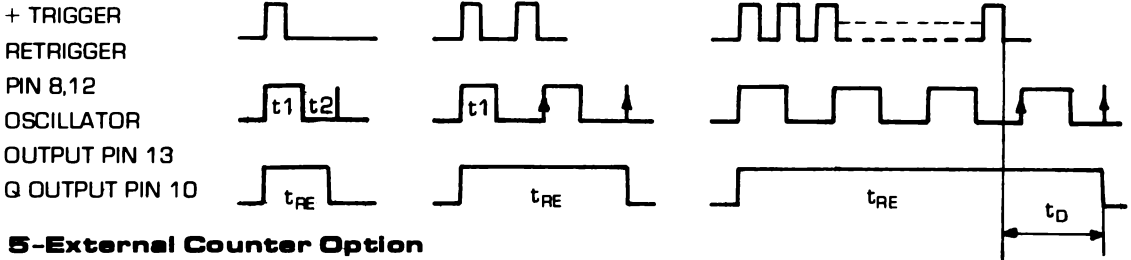

**5-External Counter Option**

Time  $t_M$  can be extended by any amount with the use of external counting circuitry. Advantages include digitally controlled pulse duration small timing capacitors for long time periods and extremely fast recovery time.

A typical implementation is shown in Fig. B. The pulse duration at the output is

$$t_{ext} = (N-1)t_A + (t_M + t_A/2)$$

where  $t_{ext}$  = pulse duration of the circuitry, and N is the number of counts used.

**6-Power Consumption**

In the standby mode (Monostable or Astable), power dissipation will be a function of leakage current in the circuit, as shown in the static electrical characteristics. For dynamic operation, the power needed to charge the external timing capacitor C is given by the following formula:

Astable Mode:  $P = 2CV^2f$ . (Output at Pin 13)  
 $P = 4CV^2f$ . (Output at Pin 10 and 11)

Monostable Mode:  $P = (1/T)(2.9 CV^2)$  (Duty Cycle). (Output at Pin 10 and 11) The circuit is designed so that most of the total power is consumed in the external components. In practice, the lower the values of frequency and voltage used, the closer the actual power dissipation will be to the calculated value. Because the power dissipation does not depend on R, a design for minimum power dissipation would be a small value of C. The value of R would depend on the desired period (within the limitations discussed above).

**7 - Timing-component limitations**

The capacitor used in the circuit should be non-polarized and have low leakage (i.e. the parallel resistance of the capacitor should be an order of magnitude greater than the external resistor used). There is no upper or lower limit for either R or C value to maintain oscillation. However, in consideration of accuracy, C must be much larger than the inherent stray capacitance in the system (unless this capacitance can be measured and taken into account). R must be much larger than the CMOS "ON" resistance in series with it, which typically is hundreds of ohms. In addition, with very large values of R, some short-term instability with respect to time may be noted.

The recommended values for these components to maintain agreement with previously calculated formulas without trimming should be:

- $C \geq 100 \text{ pF}$ , up to any practical value, for astable modes;
- $C \geq 1000 \text{ pF}$ , up to any practical value, for monostable modes.  $10k \leq R \leq 1M$ .

Fig. B' Implementation of external counter option

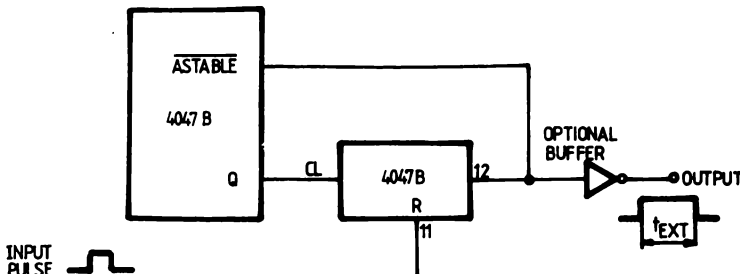

# MULTIFUNCTION EXPANDABLE 8-INPUT GATE

## GENERAL DESCRIPTION

The MMC 4048 (intermediate or extended temperature range) are monolithic integrated circuit, available in 16-lead dual in-line plastic or ceramic package. The MMC 4018 is an 8-input gate having four control inputs. Three binary control inputs  $K_a$ ,  $K_b$ , and  $K_c$  provide the implementation of eight different logic functions. These functions are OR, NOR, AND, NAND, OR/AND, OR/NAND, AND/OR and AND/NOR. A fourth control input  $K_d$  provides the user with a 3-state output. When control input  $K_d$  is high the output is either a logic 1 or logic 0 depending on the inner states. When control input  $K_d$  is low, the output is an open circuit. This feature enables the user to connect this device to a common bus line. In addition to the eight input lines, an EXPAND input is provided that permits the user to increase the number of inputs to one MMC 4048. For example, two MMC 4048 can be cascaded to provide a 16-input multifunction gate. When the EXPAND input is not used, it should be connected to  $V_{SS}$ .

## FEATURES

- Three-state output
- Many logic functions available in one package.

## ABSOLUTE MAXIMUM RATINGS

|            |  |                    |              |          |
|------------|--|--------------------|--------------|----------|
| $V_{DD}^*$ | Supply voltage: G and H types<br>E and F types   | -0.5 to<br>-0.5 to | 20<br>18     | V<br>V   |
| $V_i$      | Input voltage  | -0.5 to            | $V_{DD}+0.5$ | V        |
| $I_i$      | DC input current (any one input)   |                    | $\pm 10$     | mA       |
| $P_{tot}$  | Total power dissipation (per package)<br>Dissipation per output transistor<br>for $T_A$ = full package-temperature range |                    | 200          | mW<br>mW |
| $T_A$      | Operating<br>temperature : G and H types<br>E and F types  | -55 to<br>-40 to   | 125<br>85    | °C<br>°C |
| $T_{stg}$  | Storage temperature  | -65 to             | 150          | °C       |

\* All voltage values are referred to  $V_{SS}$  pin voltage

## RECOMMENDED OPERATING CONDITIONS

|            |   |                  |           |          |
|------------|---|------------------|-----------|----------|
| $V_{DD}^*$ | Supply voltage: G and H types<br>E and F types            | 3 to<br>3 to     | 18<br>15  | V<br>V   |
| $V_i$      | Input voltage   | 0 to             | $V_{DD}$  | V        |
| $T_A$      | Operating<br>temperature : G and H types<br>E and F types | -55 to<br>-40 to | 125<br>85 | °C<br>°C |

## CONNECTION DIAGRAM

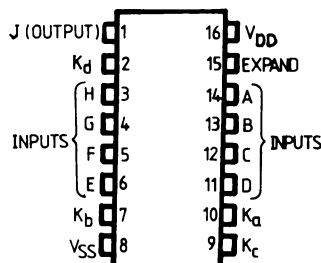

**STATIC ELECTRICAL CHARACTERISTICS**

(over recommended operating conditions)

| PARAMETER                         |                       | TEST CONDITIONS       |                       |                                |                        | VALUES                |                      |                       |                |                        |                       | UNIT                 |               |   |
|-----------------------------------|-----------------------|-----------------------|-----------------------|--------------------------------|------------------------|-----------------------|----------------------|-----------------------|----------------|------------------------|-----------------------|----------------------|---------------|---|
|                                   |                       | V <sub>I</sub><br>(V) | V <sub>O</sub><br>(V) | I <sub>O</sub>  <br>( $\mu$ A) | V <sub>DD</sub><br>(V) | T* <sub>LOW</sub>     |                      | 25°C                  |                |                        | T* <sub>HIGH</sub>    |                      |               |   |
|                                   |                       |                       |                       |                                |                        | min.                  | max.                 | min.                  | typ            | max.                   | min.                  |                      | max.          |   |
| I <sub>L</sub>                    | Quiescent current     | G, H types            | 0/ 5                  |                                |                        | 5                     |                      | 0.25                  |                | 0.01                   | 0.25                  |                      | 7.5           |   |
|                                   |                       |                       | 0/10                  |                                |                        | 10                    |                      | 0.5                   |                | 0.01                   | 0.5                   |                      | 15            |   |
|                                   |                       |                       | 0/15                  |                                |                        | 15                    |                      | 1                     |                | 0.01                   | 1                     |                      | 30            |   |
|                                   |                       |                       | 0/20                  |                                |                        | 20                    |                      | 5                     |                | 0.02                   | 5                     |                      | 150           |   |
|                                   | E, F types            | 0/ 5                  |                       |                                | 5                      |                       | 1                    |                       | 0.01           | 1                      |                       | 7.5                  |               |   |
|                                   |                       | 0/10                  |                       |                                | 10                     |                       | 2                    |                       | 0.01           | 2                      |                       | 15                   |               |   |
|                                   |                       |                       | 0/15                  |                                | 15                     |                       | 4                    |                       | 0.01           | 4                      |                       | 30                   |               |   |
| V <sub>OH</sub>                   | Output high voltage   |                       | 0/ 5<br>0/10<br>0/15  | < 1<br>< 1<br>< 1              | 5<br>10<br>15          | 4.95<br>9.95<br>14.95 |                      | 4.95<br>9.95<br>14.95 |                |                        | 4.95<br>9.95<br>14.95 |                      | V             |   |
| V <sub>OL</sub>                   | Output low voltage    |                       | 5 /0<br>10/0<br>15/0  | < 1<br>< 1<br>< 1              | 5<br>10<br>15          |                       | 0.05<br>0.05<br>0.05 |                       |                | 0.05<br>0.05<br>0.05   |                       | 0.05<br>0.05<br>0.05 | V             |   |
| V <sub>IH</sub>                   | Input high voltage    |                       |                       | 0.5/4.5<br>1/9<br>1.5/13.5     | < 1<br>< 1<br>< 1      | 5<br>10<br>15         | 3.5<br>7<br>11       |                       | 3.5<br>7<br>11 |                        |                       | 3.5<br>7<br>11       | V             |   |
| V <sub>IL</sub>                   | Input low voltage     |                       |                       | 4.5/0.5<br>9/1<br>13.5/1.5     | < 1<br>< 1<br>< 1      | 5<br>10<br>15         |                      | 1.5<br>3<br>4         |                |                        | 1.5<br>3<br>4         |                      | 1.5<br>3<br>4 | V |
| I <sub>OH</sub>                   | Output drive current  | G, H types            | 0/ 5                  | 2.5                            |                        | 5                     | -2                   |                       | -1.6           | -3.2                   |                       | -1.15                |               |   |
|                                   |                       |                       | 0/ 5                  | 4.6                            |                        | 5                     | -0.64                |                       | -0.51          | -1                     |                       | -0.36                |               |   |
|                                   |                       |                       | 0/10                  | 9.5                            |                        | 10                    | -1.6                 |                       | -1.3           | -2.6                   |                       | -0.9                 |               |   |
|                                   |                       |                       | 0/15                  | 13.5                           |                        | 15                    | -4.2                 |                       | -3.4           | -6.8                   |                       | -2.4                 |               |   |
|                                   |                       | E, F types            | 0/ 5                  | 2.5                            |                        | 5                     | -1.53                |                       | -1.36          | -3.2                   |                       | -1.1                 |               |   |
|                                   |                       |                       | 0/ 5                  | 4.6                            |                        | 5                     | -0.52                |                       | -0.44          | -1                     |                       | -0.36                |               |   |
|                                   |                       | 0/10                  | 9.5                   |                                | 10                     | -1.3                  |                      | -1.1                  | -2.6           |                        | -0.9                  |                      |               |   |
|                                   |                       | 0/15                  | 13.5                  |                                | 15                     | -3.6                  |                      | -3.0                  | -6.8           |                        | -2.4                  |                      |               |   |
| I <sub>OL</sub>                   | Output sink current   | G, H types            | 0/ 5                  | 0.4                            |                        | 5                     | 0.64                 |                       | 0.51           | 1                      |                       | 0.36                 |               |   |
|                                   |                       |                       | 0/10                  | 0.5                            |                        | 10                    | 1.6                  |                       | 1.3            | 2.6                    |                       | 0.9                  |               |   |
|                                   |                       |                       | 0/15                  | 1.5                            |                        | 15                    | 4.2                  |                       | 3.4            | 6.8                    |                       | 2.4                  |               |   |
|                                   |                       |                       | E, F types            | 0/ 5                           | 0.4                    |                       | 5                    | 0.52                  |                | 0.44                   | 1                     |                      | 0.36          |   |
|                                   |                       | 0/10                  |                       | 0.5                            |                        | 10                    | 1.3                  |                       | 1.1            | 2.6                    |                       | 0.9                  |               |   |
|                                   |                       |                       |                       | 0/15                           | 1.5                    |                       | 15                   | 3.6                   |                | 3.0                    | 6.8                   |                      | 2.4           |   |
| I <sub>IH</sub> , I <sub>IL</sub> | Input leakage current | G, H types            | 0/18                  | Any input                      |                        | 18                    |                      | $\pm$ 0.1             |                | $\pm$ 10 <sup>-5</sup> | $\pm$ 0.1             |                      | $\pm$ 1       |   |
|                                   |                       | E, F types            | 0/15                  |                                |                        | 15                    |                      | $\pm$ 0.3             |                | $\pm$ 10 <sup>-5</sup> | $\pm$ 0.3             |                      | $\pm$ 1       |   |
| I <sub>OH</sub>                   | 3-state output        | G, H types            | 0/18                  | 0/18                           |                        | 18                    |                      | $\pm$ 0.4             |                | $\pm$ 10 <sup>-4</sup> | $\pm$ 0.4             |                      | $\pm$ 12      |   |
|                                   |                       | E, F types            | 0/15                  | 0/15                           |                        | 15                    |                      | $\pm$ 1.0             |                | $\pm$ 10 <sup>-4</sup> | $\pm$ 1.0             |                      | $\pm$ 7.5     |   |

| PARAMETER                        | TEST CONDITIONS       |                       |                        |                        | VALUES             |      |      |      |      |                     | UNIT |      |
|----------------------------------|-----------------------|-----------------------|------------------------|------------------------|--------------------|------|------|------|------|---------------------|------|------|
|                                  | V <sub>I</sub><br>(V) | V <sub>O</sub><br>(V) | I <sub>O</sub><br>(μA) | V <sub>DD</sub><br>(V) | T <sub>LOW</sub> * |      | 25°C |      |      | T <sub>HIGH</sub> * |      |      |
|                                  |                       |                       |                        |                        | min.               | max. | min. | typ. | max. | min.                |      | max. |
| C <sub>I</sub> Input capacitance |                       | Any input             |                        |                        |                    |      |      | 5    | 7.5  |                     |      | pF   |

\* T<sub>LOW</sub> = -55°C for G, H devices; -40°C for E, F devices.

\* T<sub>HIGH</sub> = +125°C for G, H devices; +85°C for E, F devices.

The Noise Margin for both "1" and "0" level is:

1 V min. with V<sub>DD</sub> = 5 V

2 V min. with V<sub>DD</sub> = 10 V

2.5 V min. with V<sub>DD</sub> = 15 V

**DYNAMIC ELECTRICAL CHARACTERISTICS**

(T<sub>A</sub> = 25°C, C<sub>I</sub> = 50 pF, R<sub>I</sub> = 200 kohm, typical temperature coefficient for all V<sub>DD</sub> = 0.3%/°C values, all input rise and fall time = 20 ns)

| PARAMETER  | TEST CONDITIONS  | VALUES                     |               |                      | UNIT              |                   |
|--|--|----------------------------|---------------|----------------------|-------------------|-------------------|
|  |  | V <sub>DD</sub> (V)        | min.          | typ.                 |                   | max.              |
| t <sub>PHL</sub> , t <sub>PLH</sub> Propagation delay time<br>Inputs to output and<br>Ka to Output                       |  | 5<br>10<br>15              |               | 300<br>150<br>120    | 600<br>300<br>240 | ns                |
| Kb to Output   |  | 5<br>10<br>15              |               | 225<br>85<br>55      | 450<br>170<br>110 | ns                |
|  | Kc to Output   | 5<br>10<br>15              |               | 140<br>50<br>40      | 280<br>100<br>80  | ns                |
|  |  | Expand Input to Output     | 5<br>10<br>15 |                      | 190<br>90<br>65   | 380<br>180<br>130 |
| t <sub>PHZ</sub> , t <sub>PLZ</sub> , 3-state propagation delay time<br>t <sub>PZH</sub> , t <sub>PZL</sub> Kd to Output |  |                            | 5<br>10<br>15 | R <sub>L</sub> = 1 k | 80<br>35<br>25    | 160<br>75<br>50   |
|  | t <sub>THL</sub> , Transition time<br>t <sub>TLH</sub> |                            | 5<br>10<br>15 |                      | 100<br>50<br>40   | 200<br>100<br>80  |
|  |  | 3-state output capacitance |               |                      | 5                 | 10                |

**FUNCTION TRUTH TABLE**

| OUTPUT FUNCTION | BOOLEAN EXPRESSION                    | Ka | Kb | Kc | UNUSED INPUT    |
|-----------------|---------------------------------------|----|----|----|-----------------|
| NOR             | J = A + B + C + D + E + F + G + H     | 0  | 0  | 0  | V <sub>SS</sub> |
| OR              | J = A + B + C + D + E + F + G + H     | 0  | 0  | 1  | V <sub>SS</sub> |
| OR/AND          | J = (A + B + C + D) · (E + F + G + H) | 0  | 1  | 0  | V <sub>SS</sub> |
| OR/NAND         | J = (A + B + C + D) · (E + F + G + H) | 0  | 1  | 1  | V <sub>SS</sub> |
| AND             | J = ABCDEFGH                          | 1  | 0  | 0  | V <sub>DD</sub> |
| NAND            | J = ABCDEFGH                          | 1  | 0  | 1  | V <sub>DD</sub> |
| AND/NOR         | J = ABCD + EFGH                       | 1  | 1  | 0  | V <sub>DD</sub> |
| AND/OR          | J = ABCD + EFGH                       | 1  | 1  | 1  | V <sub>DD</sub> |

Kd = 1 Normal Inverter Action  
Kd = 0 High Impedance Output

EXPAND Input = 0

**BASIC LOGIC CONFIGURATIONS**

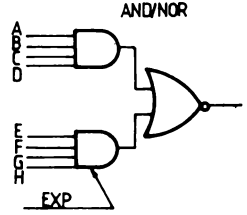
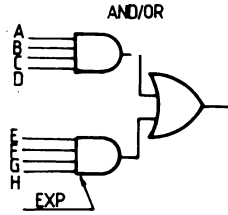
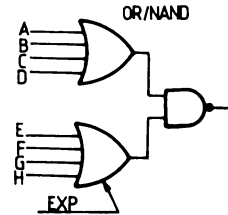
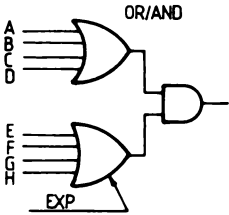
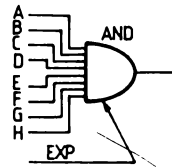
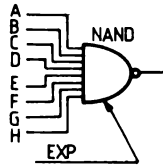
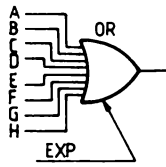
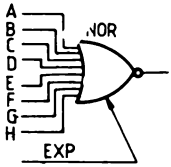

**LOGIC DIAGRAM**

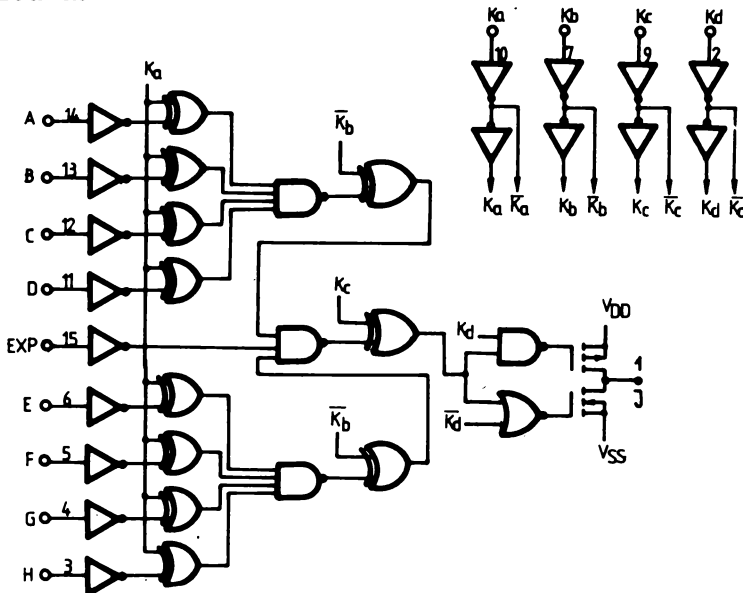

APPLICATIONS

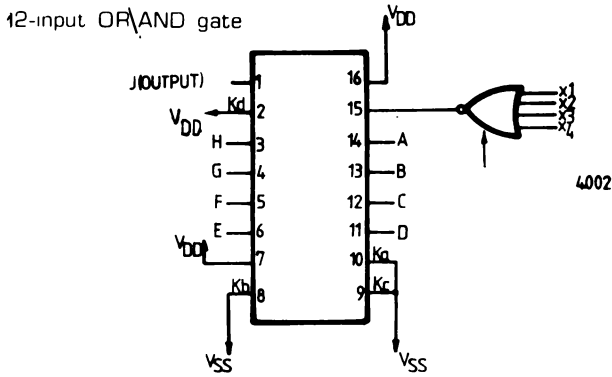

$$J = (A + B + C + D)(E + F + G + H)(X1 + X2 + X3 + X4)$$

16 - INPUT NOR GATE

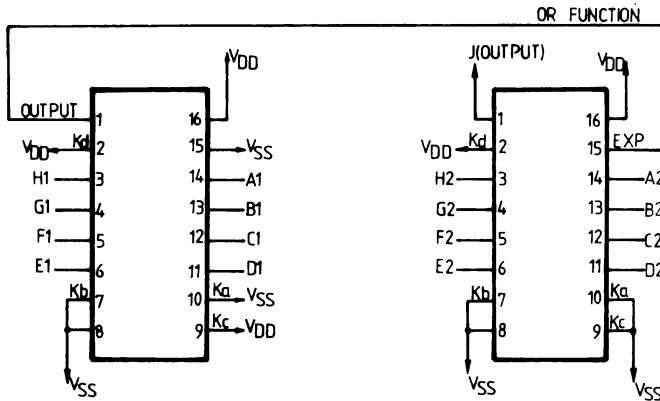

$$J = A1 + B1 + C1 + D1 + E1 + F1 + G1 + A2 + B2 + C2 + D2 + E2 + F2 + G2 + H2$$



# HEX BUFFER/CONVERTERS: MMC 4049-INVERTING TYPE MMC 4050-NON-INVERTING TYPE

## GENERAL DESCRIPTION

The MMC 4049 and the MMC 4050 are monolithic integrated circuits processed in standard Al-gate CMOS technology. The MMC 4049 and the MMC 4050 are inverting and non-inverting hex-buffers, respectively, and feature logic-level conversion using only one supply voltage ( $V_{DD}$ ). The input-signal high level ( $V_{IH}$ ) can exceed the  $V_{DD}$  supply voltage when these devices are used for logic level conversions. These devices are intended for use as CMOS to DTL/TTL converters and can drive directly two DTL/TTL loads ( $V_{DD} = 5V$ ,  $V_{OL} \leq 0.4V$ , and  $I_O \geq 3.2mA$ ).

## FEATURES

- High sink current for driving 2TTL loads
- High-to-low level logic conversion
- High sink and source current capability

## ABSOLUTE MAXIMUM RATINGS

|            |  |  |   |
|------------|--|--|---|
| $V_{DD}^*$ | Supply voltage: G and H types<br>E and F types   | -0.5 to 20<br>-0.5 to 18<br>-0.5 to $V_{DD}+0.5$ | V<br>V<br>V                               |
| $V_i$      | Input voltage  |  | V   |
| $I_i$      | DC input current (any one input)   |  | $\pm 10$ mA                               |
| $P_{tot}$  | Total power dissipation (per package)<br>Dissipation per output transistor<br>for $T_A =$ full package-temperature range |  | 200 mW<br>100 mW                          |
| $T_A$      | Operating temperature : G and H types<br>E and F types   | -55 to 125<br>-40 to 85<br>-65 to 150            | $^{\circ}C$<br>$^{\circ}C$<br>$^{\circ}C$ |
| $T_{stg}$  | Storage temperature  |  | $^{\circ}C$                               |

\* All voltage values are referred to  $V_{SS}$  pin voltage

## RECOMMENDED OPERATING CONDITIONS

|            |  |                                     |                            |
|------------|--|-------------------------------------|----------------------------|
| $V_{DD}^*$ | Supply voltage: G and H types<br>E and F types         | 3 to 18<br>3 to 15<br>0 to $V_{DD}$ | V<br>V<br>V                |
| $V_i$      | Input voltage  |                                     | V                          |
| $T_A$      | Operating temperature : G and H types<br>E and F types | -55 to 125<br>-40 to 85             | $^{\circ}C$<br>$^{\circ}C$ |

## CONNECTION DIAGRAMS

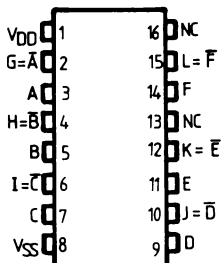
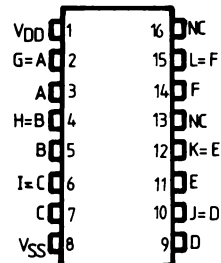
**MMC 4049**

**MMC 4050**

**STATIC ELECTRICAL CHARACTERISTICS**

(over recommended operating conditions)

| PARAMETER  |              | TEST CONDITIONS              |                           |                        | VALUES                    |                      |                                  |                              |                      |                               | UNIT                   |      |
|--|--------------|------------------------------|---------------------------|------------------------|---------------------------|----------------------|----------------------------------|------------------------------|----------------------|-------------------------------|------------------------|------|
|  |              | V <sub>I</sub><br>(V)        | V <sub>O</sub><br>(V)     | V <sub>DD</sub><br>(V) | T <sub>LOW</sub> *        |                      | 25°C                             |                              |                      | T <sub>HIGH</sub> *           |                        |      |
|  |              |                              |                           |                        | min.                      | max.                 | min.                             | typ                          | max.                 | min.                          |                        | max. |
| I <sub>L</sub> Quiescent current                       | G, H types   | 0/ 5<br>0/10<br>0/15<br>0/20 |                           | 5<br>10<br>15<br>20    |                           | 1<br>2<br>4<br>20    |                                  | 0.02<br>0.02<br>0.02<br>0.04 | 1<br>2<br>4<br>20    |                               | 30<br>60<br>120<br>600 | μA   |
|  | E, F types   | 0/ 5<br>0/10<br>0/15         |                           | 5<br>10<br>15          |                           | 4<br>8<br>16         |                                  | 0.02<br>0.02<br>0.02         | 4<br>8<br>16         |                               | 30<br>60<br>120        |      |
| V <sub>OH</sub> Output high voltage                    |              | 0/ 5<br>0/10<br>0/15         |                           | 5<br>10<br>15          | 4.95<br>9.95<br>14.95     |                      | 4.95<br>9.95<br>14.95            |                              |                      | 4.95<br>9.95<br>14.95         |                        | V    |
| V <sub>OL</sub> Output low voltage                     |              | 5 /0<br>10/0<br>15/0         |                           | 5<br>10<br>15          |                           | 0.05<br>0.05<br>0.05 |                                  |                              | 0.05<br>0.05<br>0.05 |                               | 0.05<br>0.05<br>0.05   | V    |
| V <sub>IH</sub> Input high voltage (4049)              |              |                              | 0.5<br>1<br>2             | 5<br>10<br>15          | 4<br>8<br>12              |                      | 4<br>8<br>12                     |                              |                      | 4<br>8<br>12                  |                        | V    |
| V <sub>IH</sub> Input high voltage (4050)              |              |                              | 4.5<br>9<br>13.5          | 5<br>10<br>15          | 3.5<br>7<br>11            |                      | 3.5<br>7<br>11                   |                              |                      | 3.5<br>7<br>11                |                        | V    |
| V <sub>IL</sub> Input low voltage (4049)               |              |                              | 4.5<br>9<br>13            | 5<br>10<br>15          |                           | 1<br>2<br>3          |                                  |                              | 1<br>2<br>3          |                               | 1<br>2<br>3            | V    |
| V <sub>IL</sub> Input low voltage (4050)               |              |                              | 0.5<br>1<br>1.5           | 5<br>10<br>15          | 1.5<br>3<br>4             |                      |                                  |                              | 1.5<br>3<br>4        |                               | 1.5<br>3<br>4          | V    |
| I <sub>OH</sub> Output drive current                   | G, H types   | 0/ 5<br>0/ 5<br>0/10<br>0/15 | 2.5<br>4.6<br>9.5<br>13.5 | 5<br>5<br>10<br>15     | 1.6<br>0.64<br>1.6<br>4.7 |                      | -1.25<br>-0.51<br>-1.30<br>-3.75 | -6.4<br>-1.6<br>-3.6<br>-12  |                      | -0.9<br>-0.36<br>-0.9<br>-2.6 |                        | mA   |
|  | E, F types   | 0/ 5<br>0/ 5<br>0/10<br>0/15 | 2.5<br>4.6<br>9.5<br>13.5 | 5<br>5<br>10<br>15     | 1.5<br>0.61<br>1.5<br>4.5 |                      | -1.25<br>-0.51<br>-1.25<br>-3.75 | -6.4<br>-1.6<br>-3.6<br>-12  |                      | -1<br>-0.42<br>-1<br>-3       |                        |      |
| I <sub>OL</sub> Output sink current                    | G, H types   | 0/ 5<br>0/10<br>0/15         | 0.4<br>0.5<br>1.5         | 5<br>10<br>15          | 3.75<br>10<br>30          |                      | 3.2<br>8<br>24                   | 6.4<br>16<br>48              |                      | 2.2<br>5.6<br>17              |                        | μA   |
|  | E, F types   | 0/ 5<br>0/10<br>0/15         | 0.4<br>0.5<br>1.5         | 5<br>10<br>15          | 3.6<br>9.6<br>28          |                      | 3.2<br>8<br>24                   | 6.4<br>16<br>48              |                      | 2.6<br>6.6<br>19              |                        |      |
| I <sub>IH</sub> /I <sub>IL</sub> Input leakage current | G, H types   | 0/18                         |                           | 18                     |                           | ±0.1                 |                                  | ±10 <sup>-5</sup>            | ±0.1                 |                               | ±1                     | μA   |
|  | E, F types   | 0/15                         |                           | 15                     |                           | ±0.3                 |                                  | ±10 <sup>-5</sup>            | ±0.3                 |                               | ±1                     |      |
| C <sub>I</sub> Input capacitance                       | 4049<br>4050 | Any input                    |                           |                        |                           |                      |                                  | 15<br>5                      | 22.5<br>7.5          |                               |                        | pF   |

\* T<sub>LOW</sub> = -55°C for G, H device; -40°C for E, F device

\* T<sub>HIGH</sub> = +125°C for G, H device; +85°C for E, F device

The noise margin (only MMC 4050 type) for both „1“ and „0“ level is:

1V min. with V<sub>DD</sub> = 5V  
 2V min. with V<sub>DD</sub> = 10V  
 2.5V min. with V<sub>DD</sub> = 15V

**DYNAMIC ELECTRICAL CHARACTERISTICS**

( $T_A = 25^\circ\text{C}$ ,  $C_L = 50\text{ pF}$ ,  $R_L = 200\text{ kohm}$ , typical temperature coefficient for all  $V_{DD}$  values is  $0.3\%/^\circ\text{C}$ , all input rise and fall times =  $20\text{ ns}$ ).

| PARAMETER                               | TEST CONDITIONS |              | VALUES |      |      | UNIT |
|---|-----------------|--------------|--------|------|------|------|
|   | $V_I$ (V)       | $V_{DD}$ (V) | min.   | typ. | max. |      |
| $t_{PLH}$ Propagation delay time (4049) | 5               | 5            |        | 60   | 120  | ns   |
|   | 10              | 10           |        | 32   | 65   |      |
|   | 10              | 5            |        | 45   | 90   |      |
|   | 15              | 15           |        | 25   | 50   |      |
|   | 15              | 5            |        | 45   | 90   |      |
| $t_{PLH}$ Propagation delay time (4050) | 5               | 5            |        | 70   | 140  | ns   |
|   | 10              | 10           |        | 40   | 80   |      |
|   | 10              | 5            |        | 45   | 90   |      |
|   | 15              | 15           |        | 30   | 60   |      |
|   | 15              | 5            |        | 40   | 80   |      |
| $t_{PHL}$ Propagation delay time (4049) | 5               | 5            |        | 32   | 65   | ns   |
|   | 10              | 10           |        | 20   | 40   |      |
|   | 10              | 5            |        | 15   | 30   |      |
|   | 15              | 15           |        | 15   | 30   |      |
|   | 15              | 5            |        | 10   | 20   |      |
| $t_{PHL}$ Propagation delay time (4050) | 5               | 5            |        | 55   | 110  | ns   |
|   | 10              | 10           |        | 22   | 55   |      |
|   | 10              | 5            |        | 50   | 100  |      |
|   | 15              | 15           |        | 15   | 30   |      |
|   | 15              | 5            |        | 50   | 100  |      |
| $t_{TLH}$ Transition time               | 5               | 5            |        | 80   | 160  | ns   |
|   | 10              | 10           |        | 40   | 80   |      |
|   | 15              | 15           |        | 30   | 60   |      |
| $t_{THL}$ Transition time               | 5               | 5            |        | 30   | 60   | ns   |
|   | 10              | 10           |        | 20   | 40   |      |
|   | 15              | 15           |        | 15   | 30   |      |

**SCHEMATIC DIAGRAMS**

**MMC 4049**

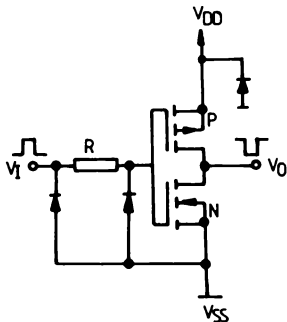

**MMC4050**

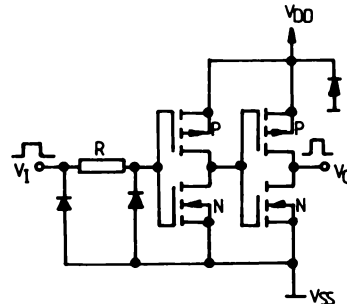

# ANALOG MULTIPLEXERS-DEMULPLEXERS:

**SINGLE 8-CHANNEL**  
**DIFFERENTIAL 4-CHANNEL**  
**TRIPLE 2-CHANNEL**

## GENERAL DESCRIPTION

The MMC 4051, MMC 4052 and MMC 4053 are monolithic integrated circuits, available in 16-lead dual-in-line plastic or ceramic package. MMC 4051, MMC 4052 and MMC 4053 analog multiplexers/demultiplexers are digitally controlled analog switches having low ON impedance and very low OFF leakage current. These multiplexer circuits dissipate extremely low quiescent power over the full  $V_{DD}-V_{SS}$  and  $V_{DD}-V_{EE}$  supply-voltage ranges, independent of the logic state of the control signals. When a logic „1“ is present at the inhibit input terminal all channel are off. The MMC 4051 is a single 8-channel multiplexer having three binary control inputs, A, B and C, and an inhibit input. The three binary signals select 1 of 8 channels to be turned on, and connect one of the 8 inputs to the output. The MMC 4052 is a differential 4-channel multiplexer having two binary control inputs, A and B, and an inhibit input. The two binary signals select 1 of 4 pairs of channels to be turned on and connect the analog inputs to the outputs.

The MMC 4053 is a triple 2-channel multiplexer having three separate digital control inputs, A, B, and C, and an inhibit input. Each control input selects one of a pair of channels which are connected in a singlepole double-throw configuration.

## FEATURES

- Low „ON“ resistance: 125 ohm (typ.) over 15 Vp.p. signal-input range for  $V_{DD}-V_{EE} = 15$  V
- High „OFF“ resistance: channel leakage  $\pm 100$  pA (typ.)  $V_{DD}-V_{EE} = 18$  V
- Binary address decoding on chip
- Very low quiescent power dissipation under all digital control input and supply conditions:  $0.2/\mu\text{W}$  (typ.),  $V_{DD}-V_{SS} = V_{DD}-V_{EE} = 10$  V
- Matched switch characteristics:  $R_{ON} = 5$  ohm (typ.) for  $V_{DD}-V_{EE} = 15$  V
- Wide range of digital and analog signal levels: digital 3 to 20 V, analog to 20 Vp.p.

## ABSOLUTE MAXIMUM RATINGS

|            |  |                    |              |  |
|------------|--|--------------------|--------------|--|
| $V_{DD}^*$ | Supply voltage: G and H types<br>E and F types   | -0.5 to<br>-0.5 to | 20<br>18     | V<br>V                                   |
| $V_i$      | Input voltage  | -0.5 to            | $V_{DD}+0.5$ | V  |
| $I_i$      | DC input current (any one input)   |                    | $\pm 10$     | mA                                       |
| $P_{tot}$  | Total power dissipation (per package)<br>Dissipation per output transistor<br>for $T_A =$ full package-temperature range |                    | 200          | mW<br>mW                                 |
| $T_A$      | Operating temperature :  | -55 to<br>-40 to   | 125<br>85    | $^{\circ}\text{C}$<br>$^{\circ}\text{C}$ |
| $T_{stg}$  | Storage temperature  | -65 to             | 150          | $^{\circ}\text{C}$                       |

\* All voltage values are referred to  $V_{SS}$  pin voltage

## RECOMMENDED OPERATING CONDITIONS

|            |  |                  |           |  |
|------------|--|------------------|-----------|--|
| $V_{DD}^*$ | Supply voltage: G and H types<br>E and F types | 3 to<br>3 to     | 18<br>15  | V<br>V                                   |
| $V_i$      | Input voltage                                  | 0 to             | $V_{DD}$  | V  |
| $T_A$      | Operating temperature :                        | -55 to<br>-40 to | 125<br>85 | $^{\circ}\text{C}$<br>$^{\circ}\text{C}$ |

## CONNECTION DIAGRAMS

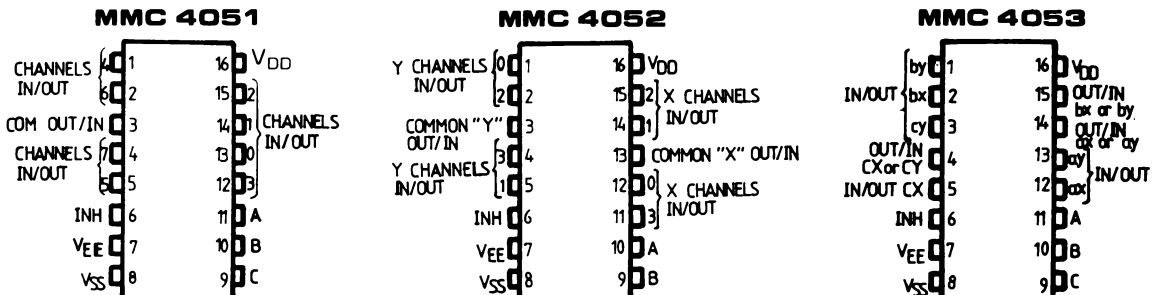

**STATIC ELECTRICAL CHARACTERISTICS**

(over recommended operating conditions)

| PARAMETER      |                          | TEST CONDITIONS        |                        |                        |                        | VALUES           |      |      |      |      |                   | UNIT |      |
|----------------|--------------------------|------------------------|------------------------|------------------------|------------------------|------------------|------|------|------|------|-------------------|------|------|
|                |                          | V <sub>IS</sub><br>(V) | V <sub>EE</sub><br>(V) | V <sub>SS</sub><br>(V) | V <sub>DD</sub><br>(V) | T <sub>LOW</sub> |      | 25°C |      |      | T <sub>HIGH</sub> |      |      |
|                |                          |                        |                        |                        |                        | min.             | max. | min. | typ. | max. | min.              |      | max. |
| I <sub>L</sub> | quiescent device current | G, H types             |                        |                        | 5                      |                  | 5    |      | 0.04 | 5    |                   | 150  |      |
|                |                          |                        |                        |                        | 10                     |                  | 10   |      | 0.04 | 10   |                   | 300  |      |
|                |                          |                        |                        |                        | 15                     |                  | 20   |      | 0.04 | 20   |                   | 600  |      |
|                |                          |                        |                        |                        | 20                     |                  | 100  |      | 0.08 | 100  |                   | 3000 |      |
|                | E, F types               |                        |                        |                        | 5                      |                  | 20   |      | 0.04 | 20   |                   | 150  |      |
|                |                          |                        |                        |                        | 10                     |                  | 40   |      | 0.04 | 40   |                   | 300  |      |
| 15             |                          |                        |                        |                        |                        | 80               |      | 0.04 | 80   |      | 600               |      |      |

**Switch**

|   |   |                                      |    |    |    |     |  |      |      |      |      |
|---|---|--------------------------------------|----|----|----|-----|--|------|------|------|------|
| ON-resistance                           | G, H types  | 0 ≤ V <sub>I</sub> ≤ V <sub>DD</sub> | 0  | 0  | 5  | 880 |  | 470  | 1050 |      | 1200 |
|   |   |                                      |    |    | 10 | 310 |  | 180  | 400  |      | 580  |
|   |   |                                      |    |    | 15 | 220 |  | 125  | 280  |      | 400  |
|   | E, F types  | 0 ≤ V <sub>I</sub> ≤ V <sub>DD</sub> | 0  | 0  | 5  | 880 |  | 470  | 1050 |      | 1200 |
|   |   |                                      |    |    | 10 | 330 |  | 180  | 400  |      | 520  |
|   |   |                                      |    |    | 15 | 230 |  | 125  | 280  |      | 360  |
| ΔON-resistance (between any 2 channels) |   |                                      | 0  | 0  | 5  |     |  | 10   |      |      |      |
|   |   |                                      |    |    | 10 |     |  | 10   |      |      |      |
|   |   |                                      |    |    | 15 |     |  | 5    |      |      |      |
| OFF (●) channel leakage current         | Any channel OFF                                       | G, H types                           | 0  | 0  | 18 | 100 |  | ±0.1 | 100  |      | 1000 |
| leakage current                         | All channels OFF (common OUT/IN)                      | G, H types                           | 0  | 0  | 18 | 100 |  | ±0.1 | 100  |      | 1000 |
|   |   |                                      |    |    |    |     |  |      |      |      |      |
|   | All channels OFF (common OUT/IN)                      | E, F types                           | 0  | 0  | 15 | 300 |  | ±0.1 | 300  | 1000 |      |
|   |   |                                      |    |    |    |     |  |      |      |      |      |
| C-capacitance                           | Input Output 4051 Output 4052 Output 4053 Feedthrough |                                      | -5 | -5 | 5  |     |  |      | 5    |      |      |
|   |   |                                      |    |    |    |     |  |      | 30   |      |      |
|   |   |                                      |    |    |    |     |  |      | 18   |      |      |
|   |   |                                      |    |    |    |     |  |      | 9    |      |      |
|   |   |                                      |    |    |    |     |  | 0.2  |      |      |      |

**Control (Address or Inhibit)**

|                 |                    |                            |  |    |     |     |     |     |    |     |
|-----------------|--------------------|----------------------------|--|----|-----|-----|-----|-----|----|-----|
| V <sub>IL</sub> | Input low voltage  | = V <sub>DD</sub> thru 1KΩ | V <sub>EE</sub> = V <sub>SS</sub><br>R <sub>L</sub> = 1KΩ to V <sub>SS</sub> | 5  |     | 1.5 |     | 1.5 |    | 1.5 |
|                 |                    |                            |  | 10 |     | 3   |     | 3   |    | 3   |
|                 |                    |                            |  | 15 |     | 4   |     | 4   |    | 4   |
| V <sub>IH</sub> | Input high voltage |                            | I <sub>S</sub> > 2μA (on all OFF channels)                                   | 5  | 3.5 |     | 3.5 |     |    | 3.5 |
|                 |                    |                            |  | 10 | 7   |     | 7   |     | 7  |     |
|                 |                    |                            |  | 15 | 11  |     | 11  |     | 11 |     |

**STATIC ELECTRICAL CHARACTERISTICS**

(over recommended operating conditions)

| PARAMETER   |            | TEST CONDITIONS              |                        |                        |                        | VALUES             |      |      |      |                   |                     | UNIT |      |    |
|---|------------|------------------------------|------------------------|------------------------|------------------------|--------------------|------|------|------|-------------------|---------------------|------|------|----|
|   |            | V <sub>IS</sub><br>(V)       | V <sub>EE</sub><br>(V) | V <sub>SS</sub><br>(V) | V <sub>DD</sub><br>(V) | T <sub>LOW</sub> * |      | 25°C |      |                   | T <sub>HIGH</sub> * |      |      |    |
|   |            |                              |                        |                        |                        | min.               | max. | min. | typ. | max.              | min.                |      | max. |    |
| I <sub>IH</sub> , I <sub>IL</sub> Input leakage current | G, H types | V <sub>I</sub> = 0/18 V      |                        |                        | 18                     |                    |      | ±0.1 |      | ±10 <sup>-3</sup> | ±0.1                |      | ±1   | µA |
|   | E, F types | V <sub>I</sub> = 0/15 V      |                        |                        | 15                     |                    |      | ±0.3 |      | ±10 <sup>-3</sup> | ±0.3                |      | ±1   |    |
| C <sub>I</sub> Input capacitance                        |            | Any address or inhibit input |                        |                        |                        |                    |      |      |      | 5                 | 7.5                 |      |      | pF |

(o) Determined by minimum feasible leakage measurement for automatic testing

(\*) T<sub>Low</sub> = -55°C for G, H device; -40°C for E, F device.

T<sub>High</sub> = +125°C for G, H device; +85°C for E, F device.

**DYNAMIC ELECTRICAL CHARACTERISTICS**

(T<sub>A</sub> = 25°C, C<sub>L</sub> = 50 pF, all input square wave rise and fall time = 20 ns)

| PARAMETER | TEST CONDITIONS        |                         |                         |                        |                        |                        | VALUES |      | UNIT |
|-----------|------------------------|-------------------------|-------------------------|------------------------|------------------------|------------------------|--------|------|------|
|           | V <sub>EE</sub><br>(V) | R <sub>L</sub><br>(K.Ω) | f <sub>i</sub><br>(KHz) | V <sub>IS</sub><br>(V) | V <sub>SS</sub><br>(V) | V <sub>DD</sub><br>(V) | typ.   | max. |      |

**Switch**

|   |                  |                |             |  |  |               |                                  |                         |                    |                |     |
|---|------------------|----------------|-------------|--|--|---------------|----------------------------------|-------------------------|--------------------|----------------|-----|
| t <sub>pd</sub> Propagation delay time (Signal input to output)                       |                  | 200            |             | 10 V  |  | 5<br>10<br>15 |                                  |                         | 30<br>15<br>11     | 30<br>60<br>20 | ns  |
| Frequency response channel „ON“ (Sine wave Input) at 20 Log $\frac{V_0}{V_1} = -3$ dB | =V <sub>SS</sub> | 1              |             | 5(*)   |  | 10            | V <sub>O</sub> at common OUT/IN  | 4053<br>4052<br>4051    | 30<br>25<br>20     |                | MHz |
|   |                  |                |             |  |  |               | V <sub>O</sub> at any channel    |                         | 60                 |                | MHz |
| Feedthrough (all channels OFF) at 20 Log $\frac{V_0}{V_1} = -40$ dB                   | =V <sub>SS</sub> | 1              |             | 5(*)   |  | 10            | V <sub>O</sub> at common OUT/IN  | 4053<br>4052<br>4051    | 8<br>10<br>12      |                | MHz |
|   |                  |                |             |  |  |               | V <sub>O</sub> at any channel    |                         | 8                  |                | MHz |
| Frequency signal crosstalk at 20 Log $\frac{V_0}{V_1} = -40$ dB                       | =V <sub>SS</sub> | 1              |             | 5(*)   |  | 10            | Between any 2 channels           |                         | 3                  |                | MHz |
|   |                  |                |             |  |  |               | Between sections 4052 only       | Measured on common      | 6                  |                |     |
|   |                  |                |             |  |  |               |                                  | Measured on any channel | 10                 |                |     |
|   |                  |                |             |  |  |               | Between any 2 sections 4053 only | In pin 2 out pin 14     | 2.5                |                |     |
|   |                  |                |             |  |  |               |                                  | In pin 15 out pin 14    | 6                  |                |     |
| Sine wave distortion f <sub>IS</sub> = 1 KHz sine wave                                | =V <sub>SS</sub> | 10<br>10<br>10 | 1<br>1<br>1 | 2(*)<br>3(*)<br>5(*)   |  | 5<br>10<br>15 |                                  |                         | 0.3<br>0.2<br>0.12 |                | %   |

| PARAMETER | TEST CONDITIONS        |                       |                         |                        |                        |                        | VALUES |      | UNIT |
|-----------|------------------------|-----------------------|-------------------------|------------------------|------------------------|------------------------|--------|------|------|
|           | V <sub>EE</sub><br>(V) | R <sub>L</sub><br>(K) | f <sub>i</sub><br>(KHz) | V <sub>IS</sub><br>(V) | V <sub>SS</sub><br>(V) | V <sub>DD</sub><br>(V) | typ.   | max. |      |

**Control (address or inhibit)**

|   |                     |     |  |  |                  |                    |   |                          |                          |            |
|---|---------------------|-----|--|--|------------------|--------------------|---|--------------------------|--------------------------|------------|
| Propagation delay time:<br>Address-to signal OUT<br>channels ON or OFF    | 0<br>0<br>0<br>- 5  |     |  |  | 0<br>0<br>0<br>0 | 5<br>10<br>15<br>5 |   | 360<br>160<br>120<br>225 | 720<br>320<br>240<br>450 | ns         |
| Propagation delay time:<br>Inhibit to signal OUT<br>(channel turning ON)  | 0<br>0<br>0<br>- 10 | 10  |  |  | 0<br>0<br>0<br>0 | 5<br>10<br>15<br>5 |   | 360<br>160<br>120<br>200 | 720<br>320<br>240<br>400 | ns         |
| Propagation delay time:<br>Inhibit to signal OUT<br>(channel turning OFF) | 0<br>0<br>0<br>- 10 | 0.3 |  |  |                  | 5<br>10<br>15<br>5 |   | 200<br>90<br>70<br>130   | 450<br>210<br>160<br>300 | ns         |
| Address or inhibit to<br>signal crosstalk                                 | 0                   | 10* |  |  | 0                | 10                 | V <sub>C</sub> = V <sub>DD</sub> - V <sub>SS</sub><br>(Square wave) | 65                       |                          | mV<br>peak |

(●) Peak to peak voltage symmetrical about  $\frac{V_{DD} - V_{EE}}{2}$

(\*): Both ends of channel.

**FUNCTIONAL DIAGRAMS AND TRUTH TABLES**

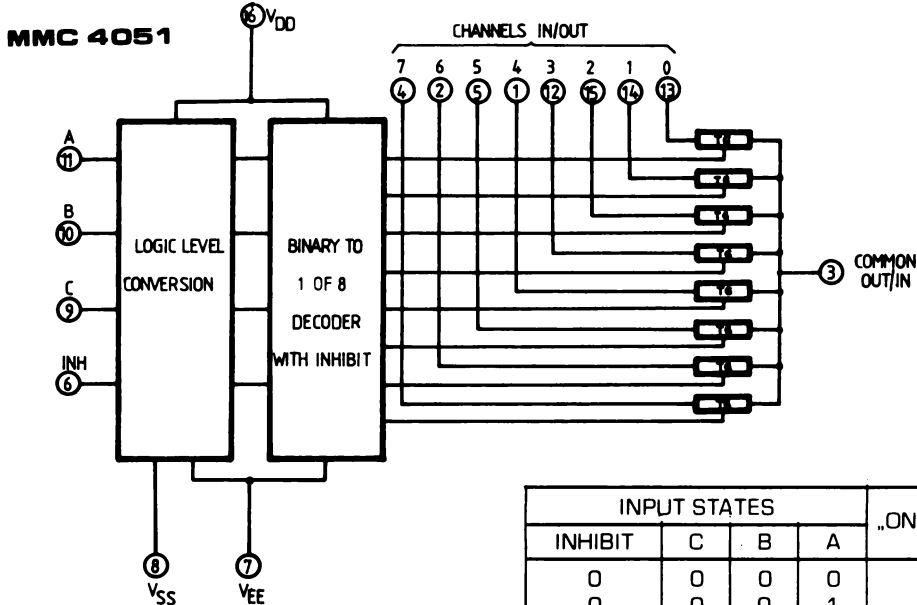

| INPUT STATES |   |   |   | „ON“ CHANNEL(S) |
|--------------|---|---|---|-----------------|
| INHIBIT      | C | B | A |                 |
| 0            | 0 | 0 | 0 | 0               |
| 0            | 0 | 0 | 1 | 1               |
| 0            | 0 | 1 | 0 | 2               |
| 0            | 0 | 1 | 1 | 3               |
| 0            | 1 | 0 | 0 | 4               |
| 0            | 1 | 0 | 1 | 5               |
| 0            | 1 | 1 | 0 | 6               |
| 0            | 1 | 1 | 1 | 7               |
| 1            | X | X | X | NONE            |

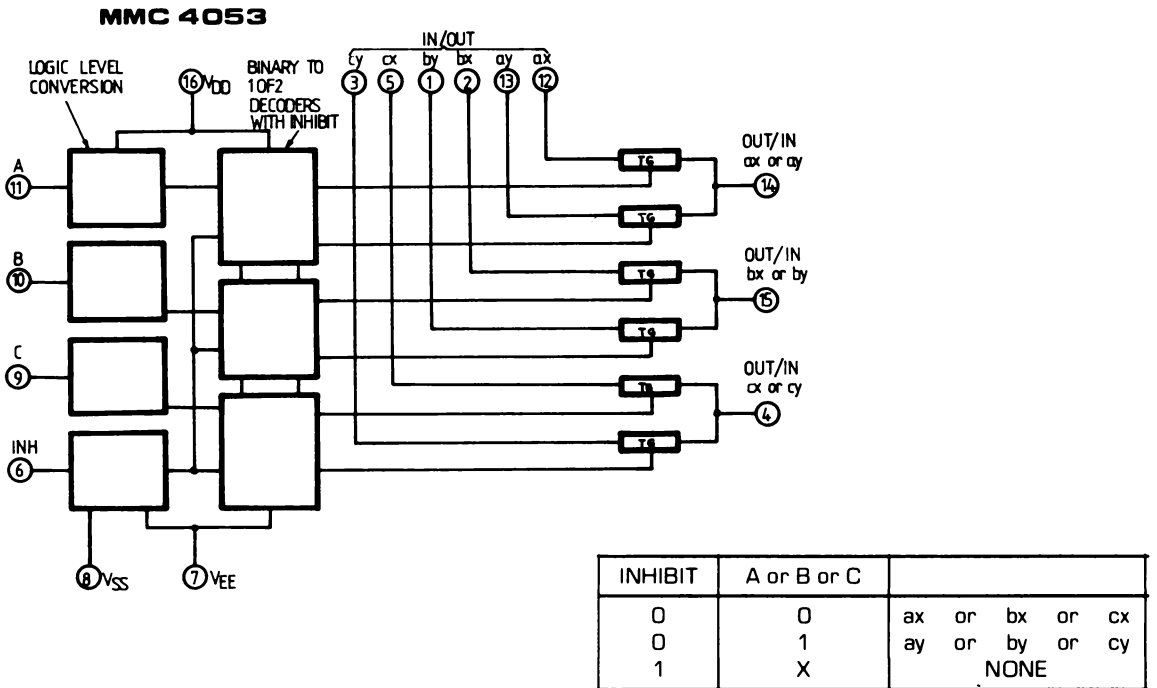
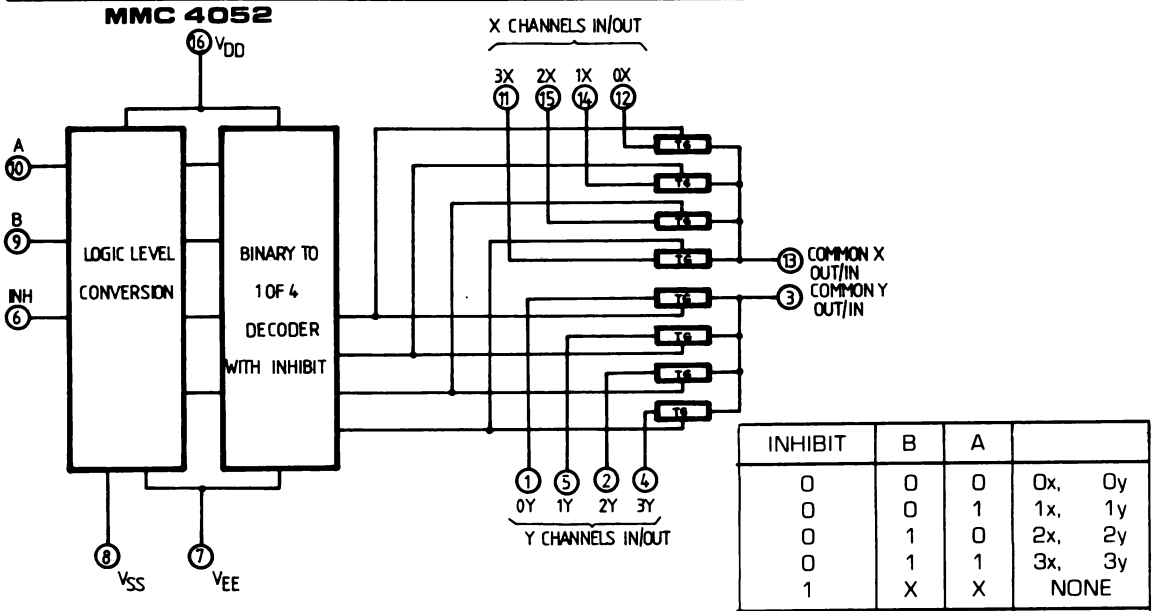

**SPECIAL CONSIDERATIONS**

Control of analog signals up to 20 V peak-to-peak can be achieved by digital signal amplitudes of 4.5 to 20 V (if  $V_{DD}-V_{SS} = 3$  V, a  $V_{DD}-V_{EE}$  of up to 13 V can be controlled; for  $V_{DD}-V_{EE}$  level differences above 13 V, a  $V_{DD}-V_{SS}$  of at least 4.5V is required). For example, if  $V_{DD} = +5$  V,  $V_{SS} = 0$ , and  $V_{EE} = -13.5$  V, analog signals from  $-13.5$  V to  $+4.5$  V can be controlled by digital inputs of 0 to 4.5V. In certain applications, the external load-resistor current may include both  $V_{DD}$  and signal-line components. To avoid drawing  $V_{DD}$  current when switch current flows into the transmission gate inputs, the voltage drop across the bidirectional switch must not exceed 0.8 volt. No  $V_{DD}$  current will flow through  $R_L$  if the switch current flows into lead 3 on the MMC 4051; leads 3 and 13 on the MMC 4052; leads 4, 14, 15 on the MMC 4053.



# 14-STAGE RIPPLE-CARRY BINARY COUNTER/ DIVIDER AND OSCILLATOR

## GENERAL DESCRIPTION

The MMC 4060 is a monolithic i.c. processed in standard Al-gate CMOS technology. This device consists of an oscillator section and 14 ripple-carry binary counter stages. The oscillator configuration allows design of either RC or crystal oscillator circuits. All counter stages are master-slave flip-flops. The state of the counter is advanced one step in binary order on the negative transition of  $\phi_1$  (and  $\phi_0$ ). A high level on the RESET line resets the counter to the all 0's state and disables the oscillator. Schmitt trigger action on the clock line permits unlimited clock rise and fall times. All inputs and outputs are fully buffered.

## FEATURES

- Medium-speed operation
- Fully static operation
- Buffered inputs and outputs
- Common reset

## ABSOLUTE MAXIMUM RATINGS

|            |  |  |               |             |
|------------|--|--|---------------|-------------|
| $V_{DD}^*$ | Supply voltage: G and H types<br>E and F types   | -0.5 to 20<br>-0.5 to 18<br>-0.5 to $V_{DD}+0.5$ | 20<br>18<br>V | V           |
| $V_i$      | Input voltage  |  | $V_{DD}+0.5$  | V           |
| $I_i$      | DC input current (any one input)   |  | $\pm 10$      | mA          |
| $P_{tot}$  | Total power dissipation (per package)<br>Dissipation per output transistor<br>for $T_A =$ full package-temperature range |  | 200           | mW          |
| $T_A$      | Operating temperature : G and H types<br>E and F types   | -55 to -40 to -65 to                             | 125 85 150    | $^{\circ}C$ |
| $T_{stg}$  | Storage temperature  |  | 150           | $^{\circ}C$ |

\* All voltage values are referred to  $V_{SS}$  pin voltage

## RECOMMENDED OPERATING CONDITIONS

|            |  |                |                |             |
|------------|--|----------------|----------------|-------------|
| $V_{DD}^*$ | Supply voltage: G and H types<br>E and F types         | 3 to 3 to 0 to | 18 15 $V_{DD}$ | V           |
| $V_i$      | Input voltage  |                | $V_{DD}$       | V           |
| $T_A$      | Operating temperature : G and H types<br>E and F types | -55 to -40 to  | 125 85         | $^{\circ}C$ |

## CONNECTION DIAGRAM

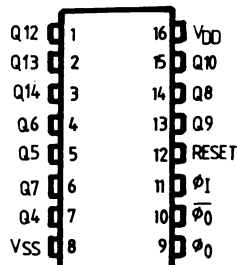

**STATIC ELECTRICAL CHARACTERISTICS**

(over recommended operating conditions)

| PARAMETER                       |                       | TEST CONDITIONS       |                       |                                |                        | VALUES             |           |       |               |           |                     | UNIT    |         |
|---------------------------------|-----------------------|-----------------------|-----------------------|--------------------------------|------------------------|--------------------|-----------|-------|---------------|-----------|---------------------|---------|---------|
|                                 |                       | V <sub>I</sub><br>(V) | V <sub>O</sub><br>(V) | I <sub>O</sub>  <br>( $\mu$ A) | V <sub>DD</sub><br>(V) | T <sub>LOW</sub> * |           | 25°C  |               |           | T <sub>HIGH</sub> * |         |         |
|                                 |                       |                       |                       |                                |                        | min.               | max.      | min.  | typ           | max.      | min.                |         | max.    |
| I <sub>L</sub>                  | Quiescent current     | G, H types            | 0/ 5                  |                                |                        | 5                  |           | 5     |               | 0.04      | 5                   |         | 150     |
|                                 |                       |                       | 0/10                  |                                |                        | 10                 |           | 10    |               | 0.04      | 10                  |         | 300     |
|                                 |                       |                       | 0/15                  |                                |                        | 15                 |           | 20    |               | 0.04      | 20                  |         | 600     |
|                                 |                       |                       | 0/20                  |                                |                        | 20                 |           | 100   |               | 0.08      | 100                 |         | 3000    |
|                                 | E, F types            | 0/ 5                  |                       |                                | 5                      |                    | 20        |       | 0.04          | 20        |                     | 150     |         |
|                                 |                       | 0/10                  |                       |                                | 10                     |                    | 40        |       | 0.04          | 40        |                     | 300     |         |
|                                 |                       | 0/15                  |                       |                                | 15                     |                    | 80        |       | 0.04          | 80        |                     | 600     |         |
| V <sub>OH</sub>                 | Output high voltage   | 0/ 5                  |                       | < 1                            | 5                      | 4.95               |           | 4.95  |               |           | 4.95                |         | V       |
|                                 |                       | 0/10                  |                       | < 1                            | 10                     | 9.95               |           | 9.95  |               |           | 9.95                |         |         |
|                                 |                       | 0/15                  |                       | < 1                            | 15                     | 14.95              |           | 14.95 |               |           | 14.95               |         |         |
| V <sub>OL</sub>                 | Output low voltage    | 5 /0                  |                       | < 1                            | 5                      |                    | 0.05      |       |               | 0.05      |                     | 0.05    | V       |
|                                 |                       | 10/0                  |                       | < 1                            | 10                     |                    | 0.05      |       |               | 0.05      |                     | 0.05    |         |
|                                 |                       | 15/0                  |                       | < 1                            | 15                     |                    | 0.05      |       |               | 0.05      |                     | 0.05    |         |
| V <sub>IH</sub>                 | Input high voltage    |                       | 0.5/4.5               | < 1                            | 5                      | 3.5                |           | 3.5   |               |           | 3.5                 |         | V       |
|                                 |                       |                       | 1/9                   | < 1                            | 10                     | 7                  |           | 7     |               |           | 7                   |         |         |
|                                 |                       |                       | 1.5/13.5              | < 1                            | 15                     | 11                 |           | 11    |               |           | 11                  |         |         |
| V <sub>IL</sub>                 | Input low voltage     |                       | 4.5/0.5               | < 1                            | 5                      |                    | 1.5       |       |               | 1.5       |                     | 1.5     | V       |
|                                 |                       |                       | 9/1                   | < 1                            | 10                     |                    | 3         |       |               | 3         |                     | 3       |         |
|                                 |                       |                       | 13.5/1.5              | < 1                            | 15                     |                    | 4         |       |               | 4         |                     | 4       |         |
| I <sub>OH</sub>                 | Output drive current  | G, H types            | 0/ 5                  | 2.5                            |                        | 5                  | -2        |       | -1.6          | -3.2      |                     | -1.15   |         |
|                                 |                       |                       | 0/ 5                  | 4.6                            |                        | 5                  | -0.64     |       | -0.51         | -1        |                     | -0.36   |         |
|                                 |                       |                       | 0/10                  | 9.5                            |                        | 10                 | -1.6      |       | -1.3          | -2.6      |                     | -0.9    |         |
|                                 |                       |                       | 0/15                  | 13.5                           |                        | 15                 | -4.2      |       | -3.4          | -6.8      |                     | -2.4    |         |
|                                 |                       | E, F types            | 0/ 5                  | 2.5                            |                        | 5                  | -1.53     |       | -1.36         | -3.2      |                     | -1.1    |         |
|                                 |                       |                       | 0/ 5                  | 4.6                            |                        | 5                  | -0.52     |       | -0.44         | -1        |                     | -0.36   |         |
|                                 |                       | 0/10                  | 9.5                   |                                | 10                     | -1.3               |           | -1.1  | -2.6          |           | -0.9                |         |         |
|                                 |                       | 0/15                  | 13.5                  |                                | 15                     | -3.6               |           | -3.0  | -6.8          |           | -2.4                |         |         |
| I <sub>OL</sub>                 | Output sink current   | G, H types            | 0/ 5                  | 0.4                            |                        | 5                  | 0.64      |       | 0.51          | 1         |                     | 0.36    |         |
|                                 |                       |                       | 0/10                  | 0.5                            |                        | 10                 | 1.6       |       | 1.3           | 2.6       |                     | 0.9     |         |
|                                 |                       |                       | 0/15                  | 1.5                            |                        | 15                 | 4.2       |       | 3.4           | 6.8       |                     | 2.4     |         |
|                                 |                       | E, F types            | 0/ 5                  | 0.4                            |                        | 5                  | 0.52      |       | 0.44          | 1         |                     | 0.36    |         |
|                                 |                       |                       | 0/10                  | 0.5                            |                        | 10                 | 1.3       |       | 1.1           | 2.6       |                     | 0.9     |         |
|                                 |                       |                       | 0/15                  | 1.5                            |                        | 15                 | 3.6       |       | 3.0           | 6.8       |                     | 2.4     |         |
| I <sub>IH</sub> I <sub>IL</sub> | Input leakage current | G, H types            | 0/18                  | Any input                      | 18                     |                    | $\pm 0.1$ |       | $\pm 10^{-5}$ | $\pm 0.1$ |                     | $\pm 1$ | $\mu$ A |
|                                 |                       | E, F types            | 0/15                  |                                | 15                     |                    | $\pm 0.3$ |       | $\pm 10^{-5}$ | $\pm 0.3$ |                     | $\pm 1$ | $\mu$ A |
| C <sub>I</sub>                  | Input capacitance     |                       | Any input.            |                                |                        |                    |           |       | 5             | 7.5       |                     | pF      |         |

\* T<sub>LOW</sub> = -55°C for G, H devices; -40°C for E, F devices.

\* T<sub>HIGH</sub> = +125°C for G, H devices; +85°C for E, F devices.

The Noise Margin for both "1" and "0" level is:

- 1 V min. with V<sub>DD</sub> = 5 V
- 2 V min. with V<sub>DD</sub> = 10 V
- 2.5 V min. with V<sub>DD</sub> = 15 V

**DYNAMIC ELECTRICAL CHARACTERISTICS**

( $T_A = 25^\circ\text{C}$ ,  $C_L = 50\text{ pF}$ ,  $R_L = 200\text{ kohm}$ , typical temperature coefficient for all  $V_{DD} = 0.3\%/^\circ\text{C}$  values, all input rise and fall time = 20 ns)

| PARAMETER  | TEST CONDITIONS  | VALUES             |      |           | UNIT |               |
|--|--|--------------------|------|-----------|------|---------------|
|  |  | $V_{DD}(\text{V})$ | Min. | Typ.      |      | Max.          |
| <b>Input-pulse operation</b>   |  |                    |      |           |      |               |
| $t_{PLH}$ Propagation delay time<br>$t_{PHL}$ ( $\emptyset$ to Q4 Out) |  | 5                  |      | 370       | 740  | ns            |
|  |  | 10                 |      | 150       | 300  |               |
|  |  | 15                 |      | 100       | 200  |               |
| $t_{PLH}$ Propagation delay time<br>$t_{PHL}$ ( $Q_n$ to $Q_{n+1}$ )   |  | 5                  |      | 100       | 200  | ns            |
|  |  | 10                 |      | 50        | 100  |               |
|  |  | 15                 |      | 40        | 80   |               |
| $t_{TLH}$ Transition time<br>$t_{THL}$                                 |  | 5                  |      | 100       | 200  | ns            |
|  |  | 10                 |      | 50        | 100  |               |
|  |  | 15                 |      | 40        | 80   |               |
| $t_W$ Input pulse width  | $f = 100\text{ kHz}$   | 5                  |      | 50        | 100  | ns            |
|  |  | 10                 |      | 20        | 40   |               |
|  |  | 15                 |      | 15        | 30   |               |
| $t_r$ $t_f$ Input rise and fall time                                   |  | 5                  |      | Unlimited |      | $\mu\text{s}$ |
|  |  | 10                 |      | Unlimited |      |               |
|  |  | 15                 |      | Unlimited |      |               |
| $f_{max}$ Maximum clock input frequency                                |  | 5                  | 3.5  | 7         |      | MHz           |
|  |  | 10                 | 8    | 16        |      |               |
|  |  | 15                 | 12   | 24        |      |               |
| <b>Reset operation</b>   |  |                    |      |           |      |               |
| $t_{PLH}$ Propagation delay time                                       |  | 5                  |      | 180       | 360  | ns            |
|  |  | 10                 |      | 80        | 160  |               |
|  |  | 15                 |      | 50        | 100  |               |
| $t_W$ Reset pulse width  |  | 5                  |      | 60        | 120  | ns            |
|  |  | 10                 |      | 30        | 60   |               |
|  |  | 15                 |      | 20        | 40   |               |
| <b>AC operation</b>  |  |                    |      |           |      |               |
| Variation of frequency<br>(Unit-to-Unit)                               | $C_x = 200\text{ pF}$  | 5                  | 18   | 21.5      | 25   | kHz           |
|  | $R_S = 560\text{ k}\Omega$   | 10                 | 20   | 23        | 26   |               |
|  | $R_x = 50\text{ k}\Omega$  | 15                 | 21.1 | 24        | 27   |               |
| Variation of frequency with voltage (Same Unit)                        | $C_x = 200\text{ pF}$<br>$R_S = 560\text{ k}\Omega$<br>$R_x = 50\text{ k}\Omega$ | 5V to 10 V         | —    | —         | 2    | kHz           |
|  |  | 10 V to 15 V       | —    | —         | 1    |               |
| $R_x$ max  | $C_x = 10\text{ }\mu\text{F}$  | 5                  | —    | —         | 20   | M $\Omega$    |
|  | $= 50\text{ }\mu\text{F}$  | 10                 | —    | —         | 20   |               |
|  | $= 10\text{ }\mu\text{F}$  | 15                 | —    | —         | 10   |               |

| PARAMETER                     | TEST CONDITIONS         | VALUES              |      |      | UNIT |      |
|-------------------------------|-------------------------|---------------------|------|------|------|------|
|                               |                         | V <sub>DD</sub> (V) | Min. | Typ. |      | Max. |
| C <sub>x</sub> max            | R <sub>x</sub> = 500 kΩ | 5                   | —    | —    | 1000 | μF   |
|                               | = 300 kΩ                | 10                  | —    | —    | 50   |      |
|                               | = 300 kΩ                | 15                  | —    | —    | 50   |      |
| Maximum Oscillator Frequency* | R <sub>x</sub> = 5 kΩ   | 10                  | 530  | 650  | 810  | kHz  |
|                               | C <sub>x</sub> = 15 pF  | 15                  | 690  | 800  | 940  |      |

\* RC oscillator applications are not recommended at supply voltages below 7 V for R<sub>x</sub> = 50 kΩ

**LOGIC DIAGRAM**

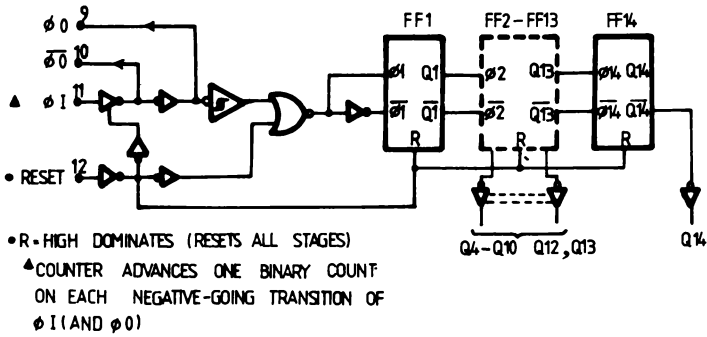

Detail of typical flip-flop stage

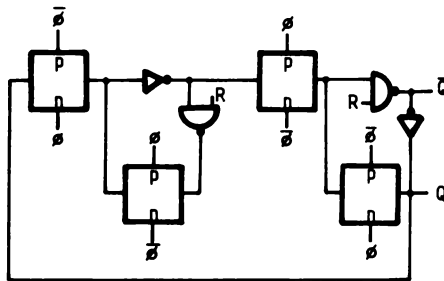

# QUAD BILATERAL SWITCH FOR TRANSMISSION OR MULTIPLEXING OF ANALOG OR DIGITAL SIGNALS

## GENERAL DESCRIPTION

The MMC 4066 (E, F — intermediate temperature range and G, H — extended temperature range) are monolithic integrated circuits, available in 14-lead dual in-line plastic or ceramic package.

The MMC 4066 is a quad bilateral switch intended for the transmission or multiplexing of analog or digital signals. It is pin-for-pin compatible with MMC 4016, but exhibits a much lower ON resistance. In addition, the ON resistance is relatively constant over the full input-signal range. The MMC 4066 consists of four independent bilateral switches. A single control signal is required per switch. Both the p and n device in a given switch are biased ON or OFF simultaneously by the control signal.

As shown in schematic diagram, the well of the n-channel device on each switch is either tied to the input when the switch is ON or to  $V_{SS}$  when the switch is OFF. This configuration eliminates the variation of the switch-transistor threshold voltage with input signal, and thus keeps the ON resistance low over the full operating-signal range. The advantages over single-channel switches include peak input signal voltage swings equal to the full supply voltage, and more constant ON impedance over the input-signal range.

## FEATURES

- 15 V digital or  $\pm 7.5$  V peak-to-peak switching
- 80  $\Omega$  typical ON resistance for 15 V operation
- Switch ON resistance matched to within 5  $\Omega$  over 15 V signal-input range
- High on/off output-voltage ratio: 65 dB typ. at  $f_{is} = 10$  kHz,  $R_L = 10$  k $\Omega$
- High degree of linearity: < 0.5% distortion typ at  $f_{is} =$  kHz,  $V_{is} = 5$  Vp-p,  $V_{DD} - V_{SS} \geq 10$  V,  $R_L = 10$  k $\Omega$
- Extremely low off switch leakage resulting in very low offset current and high effective OFF resistance; 10 pA typ at  $V_{DD} - V_{SS} = 10$  V,  $T_A = 25^\circ\text{C}$
- Extremely high control input impedance (control circuit isolated from signal circuit):  $10^{12}$   $\Omega$  typ.
- Low crosstalk between switches: -50 dB typ. at  $f_{is} = 0.9$  MHz,  $R_L = 1$  k
- Matched control-input to signal-output capacitance: reduces output signal transients

## ABSOLUTE MAXIMUM RATINGS

|            |  |  |  |
|------------|--|--|--|
| $V_{DD}^*$ | Supply voltage: G and H types<br>E and F types   | -0.5 to 20<br>-0.5 to 18<br>-0.5 to $V_{DD} + 0.5$ | V<br>V<br>V  |
| $V_i$      | Input voltage  |  | V  |
| $I_i$      | DC input current (any one input)   |  | $\pm 10$ mA  |
| $P_{tot}$  | Total power dissipation (per package)<br>Dissipation per output transistor<br>for $T_A =$ full package-temperature range |  | 200 mW<br>100 mW   |
| $T_A$      | Operating temperature : G and H types<br>E and F types   | -55 to 125<br>-40 to 85<br>-65 to 150              | $^\circ\text{C}$<br>$^\circ\text{C}$<br>$^\circ\text{C}$ |
| $T_{stg}$  | Storage temperature  |  | $^\circ\text{C}$   |

\* All voltage values are referred to  $V_{SS}$  pin voltage

## RECOMMENDED OPERATING CONDITIONS

|            |  |                                     |                                      |
|------------|--|-------------------------------------|--------------------------------------|
| $V_{DD}^*$ | Supply voltage: G and H types<br>E and F types         | 3 to 18<br>3 to 15<br>0 to $V_{DD}$ | V<br>V<br>V                          |
| $V_i$      | Input voltage  |                                     | V                                    |
| $T_A$      | Operating temperature : G and H types<br>E and F types | -55 to 125<br>-40 to 85             | $^\circ\text{C}$<br>$^\circ\text{C}$ |

## FUNCTIONAL DIAGRAM

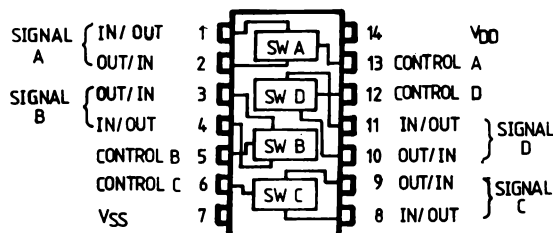

**ELECTRICAL CHARACTERISTICS**

(T<sub>A</sub> = 25°C, typical temperature coefficient for all V<sub>DD</sub> values is 0,3% /°C)

| PARAMETER   |            | TEST CONDITIONS | VALUES                |                        |                    |      |      |      |      |                     | UNIT |      |
|---|------------|-----------------|-----------------------|------------------------|--------------------|------|------|------|------|---------------------|------|------|
|   |            |                 | V <sub>I</sub><br>(V) | V <sub>DD</sub><br>(V) | T <sub>Low</sub> * |      | 25°C |      |      | T <sub>High</sub> * |      |      |
|   |            |                 |                       |                        | min.               | max. | min. | typ. | max. | min.                |      | max. |
| I <sub>L</sub> Quiescent device current (All switches ON or all switches OFF) | G, H types | 0/ 5            | 5                     |                        | 0.25               |      | 0.01 | 0.25 |      | 7.5                 | μA   |      |
|   |            | 0/10            | 10                    |                        | 0.5                |      | 0.01 | 0.5  |      | 15                  |      |      |
|   |            | 0/15            | 15                    |                        | 1                  |      | 0.01 | 1    |      | 30                  |      |      |
|   |            | 0/20            | 20                    |                        | 5                  |      | 0.02 | 5    |      | 150                 |      |      |
|   | E, F types | 0/ 5            | 5                     |                        | 1                  |      | 0.01 | 1    |      | 7.5                 |      |      |
|   |            | 0/10            | 10                    |                        | 2                  |      | 0.01 | 2    |      | 15                  |      |      |
|   |            | 0/15            | 15                    |                        | 4                  |      | 0.01 | 4    |      | 30                  |      |      |

**Signal Inputs (V<sub>is</sub>) and Outputs (V<sub>os</sub>)**

|   |            |   |    |     |     |      |      |     |
|---|------------|---|----|-----|-----|------|------|-----|
| R <sub>ON</sub> On resistance                                       | G, H types | V <sub>C</sub> = V <sub>DD</sub>  | 5  | 800 | 470 | 1050 | 1300 | Ω   |
|   |            | R <sub>L</sub> = 10 kΩ return   | 10 | 310 | 180 | 400  | 550  |     |
|   |            | to $\frac{V_{DD}-V_{SS}}{2}$  | 15 | 200 | 125 | 240  | 320  |     |
|   | E, F types | V <sub>is</sub> = V <sub>SS</sub> to V <sub>DD</sub>  | 5  | 850 | 470 | 1050 | 1200 |     |
|   |            |   | 10 | 330 | 180 | 400  | 500  |     |
|   |            |   | 15 | 210 | 125 | 240  | 300  |     |
| Δ <sub>ON</sub> Resistance Between Any 2 switches, ΔR <sub>ON</sub> |            | R <sub>L</sub> = 10kΩ, V <sub>C</sub> = V <sub>DD</sub>   | 5  |     | 15  |      |      | Ω   |
|   |            |   | 10 |     | 10  |      |      |     |
|   |            |   | 15 |     | 5   |      |      |     |
| TDH Total Harmonic Distorsion                                       |            | V <sub>C</sub> =V <sub>DD</sub> =5V, V <sub>SS</sub> =-5V, V <sub>is</sub> (p-p)=5V (Sine wave centered in 0V) R <sub>L</sub> = 10 kΩ f <sub>is</sub> = 1 kHz sine wave                                 |    |     | 0.4 |      |      | %   |
| -3dB Cutoff Frequency (switch on)                                   |            | V <sub>C</sub> =V <sub>DD</sub> =5V, V <sub>SS</sub> =-5V, V <sub>is</sub> (p-p)=5V (Sine wave centered on 0V) R <sub>L</sub> = 1 kΩ  |    |     | 40  |      |      | MHz |
| -50dB Fedthrough Frequency (switch off)                             |            | V <sub>C</sub> =V <sub>DD</sub> =5V, V <sub>is</sub> (p-p)=5V (Sine wave centered on 0V) R <sub>L</sub> = 1 kΩ  |    |     | 1   |      |      | MHz |
| -50dB Crosstalk Frequency   |            | V <sub>C</sub> (A) = V <sub>DD</sub> = +5V<br>V <sub>C</sub> (B) = V <sub>SS</sub> = -5V<br>V <sub>is</sub> (A) = 5Vp-p, 50Ω source<br>R <sub>L</sub> = 1 kΩ  |    |     | 8   |      |      | MHz |
| t <sub>pd</sub> Propagation delay (Signal Input to Signal output)   |            | R <sub>L</sub> = 200 kΩ<br>V <sub>C</sub> =V <sub>DD</sub> , V <sub>SS</sub> = GND, C <sub>L</sub> =50 pF, V <sub>is</sub> = 10V (Square wave centred on 5V)<br>t <sub>r</sub> = t <sub>f</sub> = 20 ns | 5  |     | 20  | 40   |      | ns  |
|   |            |   | 10 |     | 10  | 20   |      |     |
|   |            |   | 15 |     | 7   | 15   |      |     |
| C <sub>is</sub> Input capacitance                                   |            | V <sub>DD</sub> = +5V   |    |     | 8   |      |      | pF  |
| C <sub>os</sub> Output capacitance                                  |            | V <sub>C</sub> =V <sub>SS</sub> = -5V   |    |     | 8   |      |      |     |
| C <sub>ios</sub> Feedthrough  |            |   |    |     | 0.5 |      |      |     |

| PARAMETER   |            | TEST CONDITIONS   | VALUES                 |                  |      |      |                   |      |                   |      | UNIT |
|---|------------|---|------------------------|------------------|------|------|-------------------|------|-------------------|------|------|
|   |            |   | V <sub>DD</sub><br>(V) | T <sub>LOW</sub> |      | 25°C |                   |      | T <sub>HIGH</sub> |      |      |
|   |            |   |                        | min.             | max. | min. | typ               | max. | min.              | max. |      |
| Input/Output Leakage current switch OFF               | G, H types | V <sub>C</sub> =0V<br>V <sub>is</sub> = 18V; V <sub>os</sub> = 0V<br>V <sub>is</sub> = 0V; V <sub>os</sub> = 18V  | 18                     |                  | ±0.1 |      | ±10 <sup>-3</sup> | ±0.1 |                   | ±1   | μA   |
|   | E, F types | V <sub>C</sub> =0V<br>V <sub>is</sub> = 15V; V <sub>os</sub> = 0V<br>V <sub>is</sub> = 0V; V <sub>os</sub> = 15V  | 15                     |                  | ±0.3 |      | ±10 <sup>-3</sup> | ±0.3 |                   | ±1   |      |
| <b>Control (V<sub>C</sub>)</b>                        |            |   |                        |                  |      |      |                   |      |                   |      |      |
| V <sub>ILC</sub> Control input Low voltage            |            | I <sub>is</sub>   < 10 μA<br>V <sub>is</sub> = V <sub>SS</sub> ; V <sub>os</sub> = V <sub>DD</sub><br>and<br>V <sub>is</sub> = V <sub>DD</sub> ; V <sub>os</sub> = V <sub>SS</sub>  | 5                      |                  | 1    |      |                   | 1    |                   | 1    | V    |
|   |            |   | 10                     |                  | 2    |      |                   | 2    |                   | 2    |      |
|   |            |   | 15                     |                  | 2    |      |                   | 2    |                   | 2    |      |
| V <sub>IHC</sub> Control input High voltage           |            |   | 5                      | 3.5              |      | 3.5  |                   |      | 3.5               |      | V    |
|   |            |   | 10                     | 7                |      | 7    |                   |      | 7                 |      |      |
|   |            |   | 15                     | 11               |      | 11   |                   |      | 11                |      |      |
| I <sub>IH</sub> I <sub>IL</sub> Input leakage current | G, H types | V <sub>is</sub> ≤ V <sub>DD</sub><br>V <sub>DD</sub> - V <sub>SS</sub> = 18 V   | 18                     |                  | ±0.1 |      | ±10 <sup>-5</sup> | ±0.1 |                   | ±1   | μA   |
|   | E, F types | V <sub>DD</sub> - V <sub>SS</sub> = 15 V<br>V <sub>CC</sub> ≤ V <sub>DD</sub> - V <sub>SS</sub>   | 15                     |                  | ±0.3 |      | ±10 <sup>-5</sup> | ±0.3 |                   | ±1   |      |
| Crosstalk (control input to signal output)            |            | V <sub>C</sub> = 10 V (Sq. wave)<br>t <sub>r</sub> , t <sub>f</sub> = 20 ns<br>R <sub>L</sub> = 10 kΩ   | 10                     |                  |      |      | 50                |      |                   |      | mW   |
| Turn-On propagation delay                             |            | V <sub>IN</sub> = V <sub>DD</sub> ; t <sub>r</sub> ,<br>t <sub>f</sub> = 20 ns;<br>C <sub>L</sub> = 50 pF,<br>R <sub>L</sub> = 1 kΩ   | 5                      |                  |      |      | 35                | 70   |                   |      | ns   |
|   |            |   | 10                     |                  |      |      | 20                | 40   |                   |      |      |
|   |            |   | 15                     |                  |      |      | 15                | 30   |                   |      |      |
| Control input Repetition rate                         |            | V <sub>is</sub> = V <sub>DD</sub> , V <sub>SS</sub> = GND<br>R <sub>L</sub> = 1 kΩ to gnd<br>C <sub>L</sub> = 50 pf<br>V <sub>C</sub> = 10 V (Square wave centered on 5 V)<br>t <sub>r</sub> , t <sub>f</sub> = 20 ns<br>V <sub>os</sub> = 1/2 V <sub>os</sub> ○<br>1 KHZ | 5                      |                  |      |      | 6                 |      |                   |      | MHz  |
|   |            |   | 10                     |                  |      |      | 9                 |      |                   |      |      |
|   |            |   | 15                     |                  |      |      | 9.5               |      |                   |      |      |
| C <sub>I</sub> Input capacitance                      |            | Any input   |                        |                  |      |      | 5                 | 7.5  |                   |      | pF   |

\* T<sub>LOW</sub> = -55°C for G, H devices; -40°C for E, F devices.

\* T<sub>HIGH</sub> = +125°C for G, H devices; +85°C for E, F devices.

The Noise Margin for both "1" and "0" level is:

- 1 V min. with V<sub>DD</sub> = 5 V
- 2 V min. with V<sub>DD</sub> = 10 V
- 2.5 V min. with V<sub>DD</sub> = 15 V

**SCHEMATIC DIAGRAM**

1 of 4 identical switches and its associated control circuitry

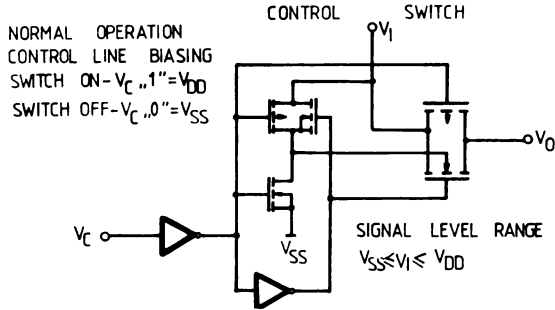

**TYPICAL APPLICATIONS**

Bidirectional signal transmission via digital control logic

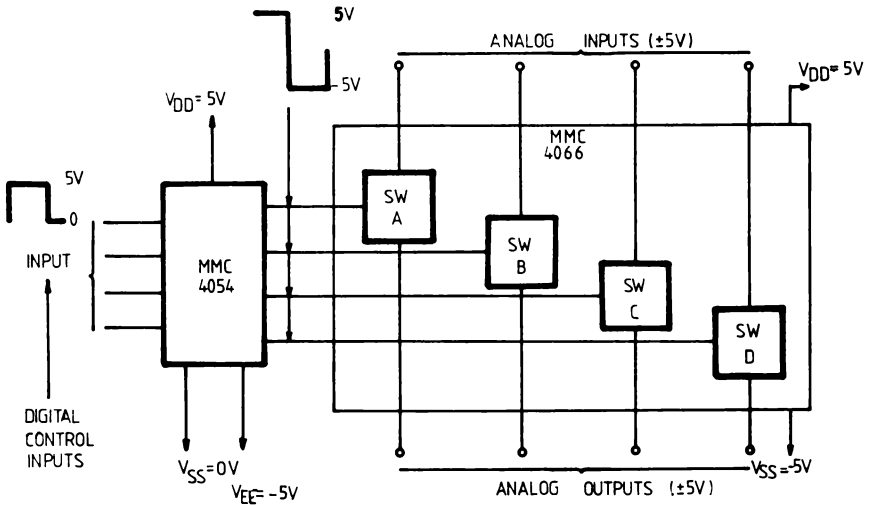



# ANALOG MULTIPLEXERS / DEMULTIPLEXERS:

## MMC 4067: SINGLE 16-CHANNEL

## MMC 4097: DIFFERENTIAL 8-CHANNEL

### GENERAL DESCRIPTION

The MMC 4067, MMC 4097 are monolithic integrated circuits, available in 24-lead dual-in-line plastic package.

The MMC 4067, MMC 4097 analog multiplexers/demultiplexers are digitally controlled analog switches having low ON impedance, low OFF leakage current, and internal address decoding. In addition, the ON resistance is relatively constant over the full input-signal range.

The MMC 4067 is a 16-channel multiplexer with four binary control inputs A, B, C, D, and an inhibit input, arranged so that any combination of the inputs selects one switch.

The MMC 4097 is a differential 8-channel multiplexer having three binary control inputs A, B, C, and an inhibit input. The inputs permit selection of one of eight pairs of switches. A logic "1" present at the inhibit input turns all channels off.

### FEATURES

- Low on resistance: 125 $\Omega$  (typ.) over 15 V<sub>p-p</sub> signal-input range for V<sub>DD</sub>V<sub>SS</sub> = 15 V
- High off resistance: channel leakage of +/−10 pA (typ.) for V<sub>DD</sub>V<sub>SS</sub> = 15 V
- Matched switch characteristics:  $\Delta R_{on} = 5\Omega$  (typ.) for V<sub>DD</sub>V<sub>SS</sub> = 15 V
- Very low quiescent power dissipation under all digital-control input and supply conditions: 0.2.  $\mu$ W (typ.) for V<sub>DD</sub>V<sub>SS</sub> = 10 V
- Binary address decoding on chip

### ABSOLUTE MAXIMUM RATINGS

|                   |   |  |                  |
|-------------------|---|--|------------------|
| V <sub>DD</sub> * | Supply voltage: G and H types<br>E and F types  | -0.5 to 20<br>-0.5 to 18<br>-0.5 to V <sub>DD</sub> +0.5 | V<br>V<br>V      |
| V <sub>i</sub>    | Input voltage   |  | V                |
| I <sub>i</sub>    | DC input current (any one input)  |  | ±10 mA           |
| P <sub>tot</sub>  | Total power dissipation (per package)<br>Dissipation per output transistor<br>for T <sub>A</sub> = full package-temperature range |  | 200 mW<br>100 mW |
| T <sub>A</sub>    | Operating temperature : G and H types<br>E and F types  | -55 to 125<br>-40 to 85<br>-65 to 150                    | °C<br>°C<br>°C   |
| T <sub>stg</sub>  | Storage temperature   |  | 150 °C           |

\* All voltage values are referred to V<sub>SS</sub> pin voltage

### RECOMMENDED OPERATING CONDITIONS

|                   |  |  |                 |
|-------------------|--|--|-----------------|
| V <sub>DD</sub> * | Supply voltage: G and H types<br>E and F types         | 3 to 18<br>3 to 15<br>0 to V <sub>DD</sub> | V<br>V<br>V     |
| V <sub>i</sub>    | Input voltage  |  | V <sub>DD</sub> |
| T <sub>A</sub>    | Operating temperature : G and H types<br>E and F types | -55 to 125<br>-40 to 85                    | °C<br>°C        |

### CONNECTION DIAGRAM

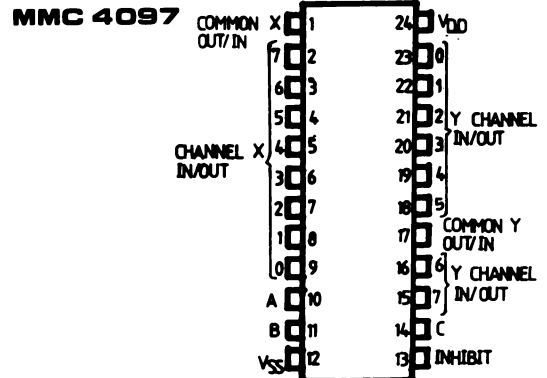
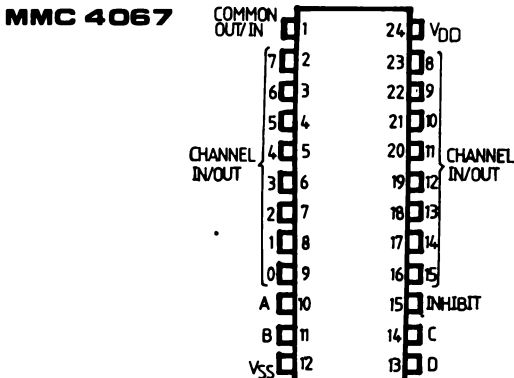

**STATIC ELECTRICAL CHARACTERISTICS**

(over recommended operating conditions)

| PARAMETER                               |               | TEST CONDITIONS        |                        |                        |                        | T <sub>LOW</sub> (●) |                      | VALUES |                              |                      | T <sub>HIGH</sub> (●) |                           | UNIT |
|---|---------------|------------------------|------------------------|------------------------|------------------------|----------------------|----------------------|--------|------------------------------|----------------------|-----------------------|---------------------------|------|
|   |               | V <sub>IS</sub><br>(V) | V <sub>EE</sub><br>(V) | V <sub>SS</sub><br>(V) | V <sub>DD</sub><br>(V) | min.                 | max.                 | 25°C   |                              |                      | min.                  | max.                      |      |
|   |               |                        |                        |                        |                        |                      |                      | min.   | typ                          | max.                 |                       |                           |      |
| I <sub>L</sub> Quiescent device current | G and H types |                        |                        |                        | 5<br>10<br>15<br>20    |                      | 5<br>10<br>20<br>100 |        | 0.04<br>0.04<br>0.04<br>0.08 | 5<br>10<br>20<br>100 |                       | 150<br>300<br>600<br>3000 | μA   |
|   | E and F types |                        |                        |                        | 5<br>10<br>15          |                      | 20<br>40<br>80       |        | 0.04<br>0.04<br>0.04         | 20<br>40<br>80       |                       | 150<br>300<br>600         |      |

**Switch**

|   |                                  |                                      |   |    |               |     |                   |        |                   |                    |      |                    |    |
|---|----------------------------------|--------------------------------------|---|----|---------------|-----|-------------------|--------|-------------------|--------------------|------|--------------------|----|
| ON Resistance                           | G and H types                    | 0 ≤ V <sub>I</sub> ≤ V <sub>DD</sub> | 0 | 0  | 5<br>10<br>15 |     | 800<br>310<br>200 |        | 470<br>180<br>125 | 1050<br>400<br>240 |      | 1300<br>580<br>320 | Ω  |
|   | E and F types                    | 0 ≤ V <sub>I</sub> ≤ V <sub>DD</sub> | 0 | 0  | 5<br>10<br>15 |     | 850<br>330<br>210 |        | 470<br>180<br>125 | 1050<br>400<br>240 |      | 1200<br>520<br>300 |    |
| ΔON Resistance (Between any 2 channels) |                                  |                                      | 0 | 0  | 5<br>10<br>15 |     |                   |        | 10<br>10<br>5     |                    |      |                    | Ω  |
| OFF(●)Any leakage current               | channel OFF                      | G and H types                        |   | 0  | 0             | 18  | 100               |        | +/-0.1            | 100                |      | 1000               | nA |
|   | All channels OFF (common OUT/IN) | G and H types                        |   | 0  | 0             | 18  | 100               |        | +/-0.1            | 100                |      | 1000               | nA |
| Any channel OFF                         | E and F types                    |                                      | 0 | 0  | 15            | 300 |                   | +/-0.1 | 300               |                    | 1000 | nA                 |    |
|   | All channels OFF (common OUT/IN) | E and F types                        | 0 | 0  | 15            | 300 |                   | +/-0.1 | 300               |                    | 1000 | nA                 |    |
| C Input                                 |                                  |                                      |   |    |               |     |                   |        | 5                 |                    |      |                    |    |
| Capacitance                             | Output 4067                      |                                      |   |    |               |     |                   |        | 55                |                    |      |                    | pF |
|   | Output 4097                      |                                      |   |    |               |     |                   |        | 35                |                    |      |                    |    |
|   | Feedthrough                      |                                      |   | -5 | 5             |     |                   |        | 0.2               |                    |      |                    |    |

**Control (Address or Inhibit)**

|                                       |                            |   |    |     |      |     |                   |      |     |    |    |
|---------------------------------------|----------------------------|---|----|-----|------|-----|-------------------|------|-----|----|----|
| V <sub>IL</sub> Input low voltage     | =V <sub>DD</sub> thru 1 kΩ | V <sub>EE</sub> =V <sub>SS</sub><br>R <sub>L</sub> = 1K to V <sub>SS</sub><br>I <sub>IS</sub> = 2μA (on all OFF channels) | 5  |     | 1.5  |     | 1.5               |      | 1.5 |    |    |
|                                       |                            |   | 10 |     | 3    |     | 3                 |      | 3   |    |    |
| V <sub>IH</sub> Input high voltage    |                            |   | 15 |     | 4    |     | 4                 |      | 4   |    |    |
|                                       |                            |   | 5  | 3.5 |      | 3.5 |                   | 3.5  |     |    |    |
|                                       |                            |   | 10 | 7   |      | 7   |                   | 7    |     |    |    |
|                                       |                            |   | 15 | 11  |      | 11  |                   | 11   |     |    |    |
| I <sub>IH</sub> Input leakage current | G and H types              | V <sub>I</sub> =0/18  | 18 |     | ±0.1 |     | ±10 <sup>-3</sup> | ±0.1 |     | ±1 | μA |
|                                       | E and F types              | V <sub>I</sub> =0/15  | 15 |     | ±0.3 |     | ±10 <sup>-3</sup> | ±0.3 |     | ±1 | μA |

| PARAMETER            | TEST CONDITIONS              |                       |                          |                        | VALUES             |      |      |      |      |                     | UNIT |      |
|----------------------|------------------------------|-----------------------|--------------------------|------------------------|--------------------|------|------|------|------|---------------------|------|------|
|                      | V <sub>I</sub><br>(V)        | V <sub>O</sub><br>(V) | I <sub>O</sub>  <br>(μA) | V <sub>DD</sub><br>(V) | T <sub>LOW</sub> * |      | 25°C |      |      | T <sub>HIGH</sub> * |      |      |
|                      |                              |                       |                          |                        | min.               | max. | min. | typ. | max. | min.                |      | max. |
| CI Input capacitance | Any address or inhibit input |                       |                          |                        |                    |      |      | 5    | 7.5  |                     |      | pF   |

- Determined by minimum feasible leakage measurement for automatic testing
- \* T<sub>LOW</sub> = -55°C for G and H types; -40°C for E and F types
- T<sub>HIGH</sub> = +125°C for G and H types; +85°C for E and F types

**DYNAMIC ELECTRICAL CHARACTERISTICS**

(T<sub>amb</sub> = 25°C, C<sub>L</sub> = 50 pF, all input square wave rise and fall times = 20 ns)

| PARAMETER | TEST CONDITIONS       |                        |                         |                       |                        |                        | VALUES |      | UNIT |
|-----------|-----------------------|------------------------|-------------------------|-----------------------|------------------------|------------------------|--------|------|------|
|           | V <sub>C</sub><br>(V) | R <sub>L</sub><br>(kΩ) | f <sub>i</sub><br>(kHz) | V <sub>i</sub><br>(V) | V <sub>SS</sub><br>(V) | V <sub>DD</sub><br>(V) | TYP.   | MAX. |      |

**Switch**

|   |  |                |             |   |             |               |   |                         |                |     |  |
|---|--|----------------|-------------|---|-------------|---------------|---|-------------------------|----------------|-----|--|
| t <sub>pd</sub> Propagation delay time (Signal input to output)                                     | = V <sub>DD</sub>  | 200            |             |  | 0           | 5<br>10<br>15 |   | 30<br>15<br>11          | 60<br>30<br>20 | ns  |  |
| Frequency response channel „ON“ (Sine wave input) at 20 Log(V <sub>O</sub> /V <sub>i</sub> ) = -3dB | = V <sub>DD</sub>  | 1              |             | 5(●)  | 0           | 10            | V <sub>O</sub> at common 4067 OUT/IN 4097 | 14<br>20                |                | MHz |  |
|   |  |                |             |   |             |               | V <sub>O</sub> at any channel             | 60                      |                | MHz |  |
| Feedthrough (all channels OFF) at 20 Log(V <sub>O</sub> /V <sub>i</sub> ) = -40dB                   | = V <sub>SS</sub>  | 1              |             | 5(●)  | 0           | 10            | V <sub>O</sub> at common 4067 OUT/IN 4097 | 20<br>12                |                | MHz |  |
|   |  |                |             |   |             |               | V <sub>O</sub> at any channel             | 8                       |                |     |  |
| Frequency signal crosstalk at 20 Log(V <sub>C(A)</sub> /V <sub>i(A)</sub> ) = -40 dB                | V <sub>C(A)</sub> = V <sub>DD</sub><br>V <sub>C(B)</sub> = V <sub>SS</sub> | 1              |             | 5(●)  | 0           | 10            | Between any (A and B) channels            | 1                       |                | MHz |  |
|   |  |                |             |   |             |               | Between sections (A and B) 4097 only      | Measured on common      | 10             |     |  |
|   |  |                |             |   |             |               |   | Measured on any channel | 18             |     |  |
| Sine wave distortion f <sub>is</sub> = 1 kHz sine wave  | 5<br>10<br>15  | 10<br>10<br>10 | 1<br>1<br>1 | 2(●)<br>3(●)<br>5(●)  | 0<br>0<br>0 | 5<br>10<br>15 |   | 0.3<br>0.2<br>0.12      |                | %   |  |

**Control (Address or inhibit)**

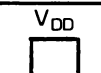
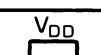
|  |   |                 |     |  |  |             |               |  |                  |                   |         |
|--|---|-----------------|-----|--|--|-------------|---------------|--|------------------|-------------------|---------|
| Propagation delay time: address or inhibit to signal OUT (channel turning ON)  |  | V <sub>DD</sub> | 10  |  |  | 0<br>0<br>0 | 5<br>10<br>15 |  | 325<br>135<br>95 | 650<br>270<br>190 | ns      |
| Propagation delay time: address or inhibit to signal OUT (channel turning OFF) |  | V <sub>DD</sub> | 0.3 |  |  | 0<br>0<br>0 | 5<br>10<br>15 |  | 220<br>90<br>65  | 440<br>180<br>130 | ns      |
| Address or inhibit to signal crosstalk   |  | V <sub>DD</sub> | 10* |  |  | 0           | 10            |  | 75               |                   | mV peak |

\* Both ends of channel

● peak to peak voltage symmetrical about (V<sub>DD</sub> - V<sub>SS</sub>)/2

LOGIC DIAGRAM

MMC 4067

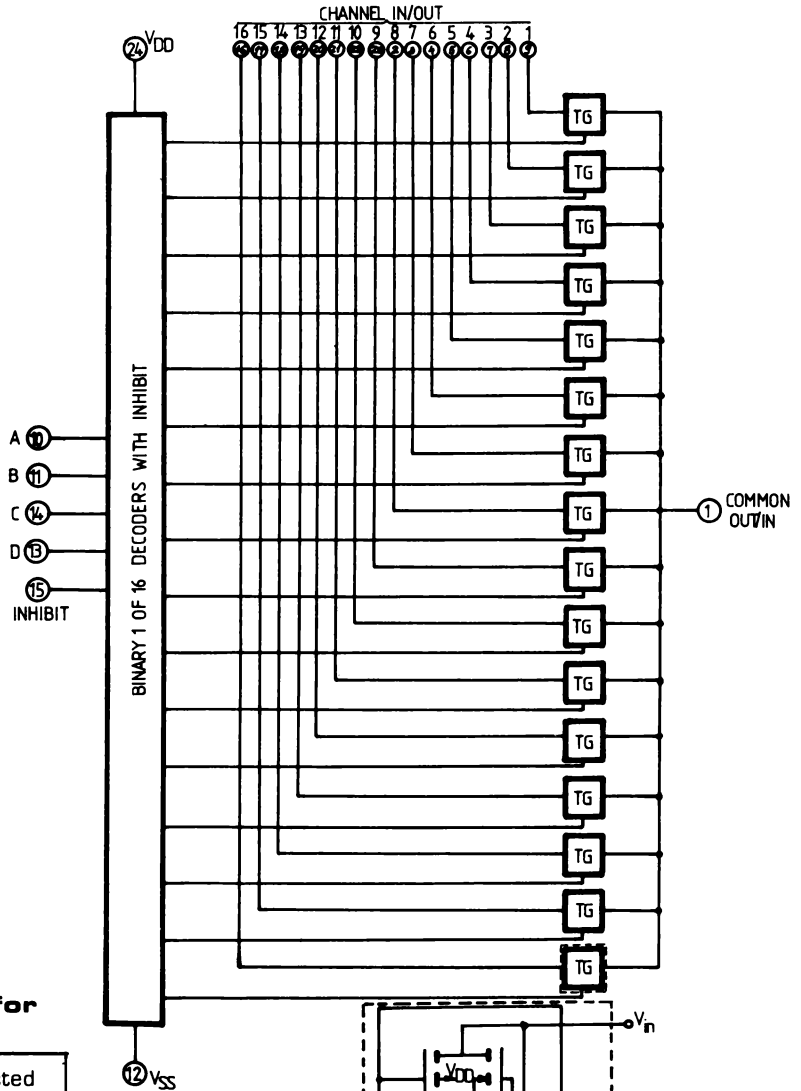

TRUTH TABLE for MMC 4067

| A | B | C | D | Inh | Selected channel |
|---|---|---|---|-----|------------------|
| X | X | X | X | 1   | None             |
| 0 | 1 | 0 | 0 | 0   | 0                |
| 1 | 0 | 0 | 0 | 0   | 1                |
| 0 | 1 | 1 | 0 | 0   | 2                |
| 1 | 0 | 1 | 0 | 0   | 3                |
| 0 | 0 | 0 | 1 | 0   | 4                |
| 1 | 0 | 0 | 1 | 0   | 5                |
| 0 | 1 | 1 | 1 | 0   | 6                |
| 1 | 0 | 1 | 1 | 0   | 7                |
| 0 | 0 | 0 | 0 | 1   | 8                |
| 1 | 0 | 0 | 0 | 1   | 9                |
| 0 | 1 | 1 | 0 | 1   | 10               |
| 1 | 0 | 1 | 1 | 1   | 11               |
| 0 | 1 | 0 | 1 | 1   | 12               |
| 1 | 0 | 1 | 1 | 1   | 13               |
| 0 | 1 | 1 | 1 | 1   | 14               |
| 1 | 1 | 1 | 1 | 0   | 15               |

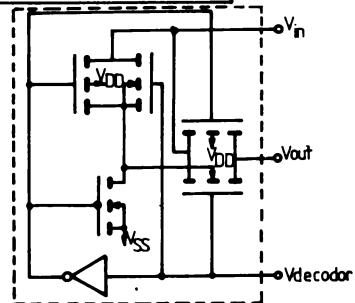

MMC 4097

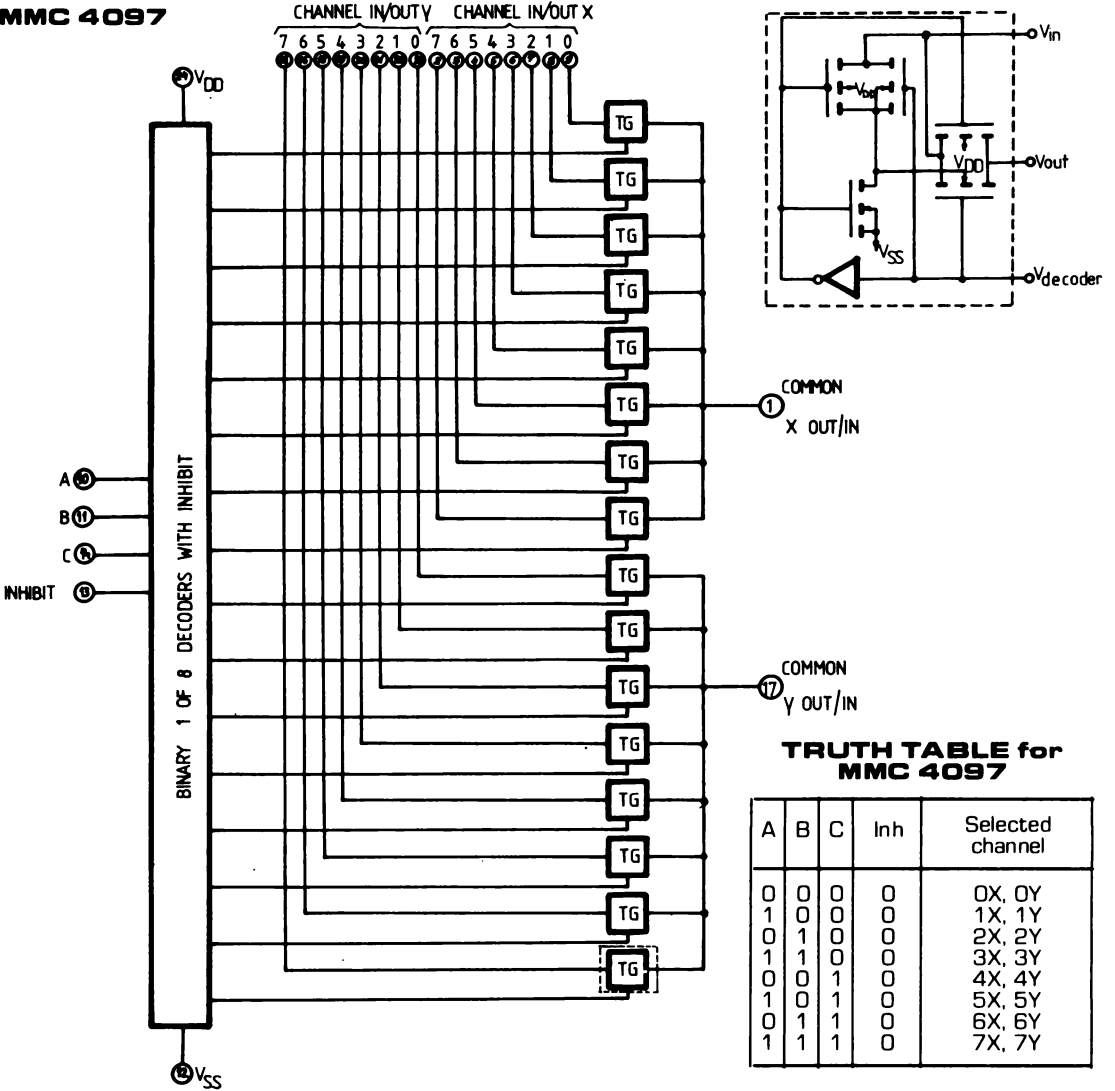

TRUTH TABLE for MMC 4097

| A | B | C | Inh | Selected channel |
|---|---|---|-----|------------------|
| 0 | 0 | 0 | 0   | 0X, 0Y           |
| 1 | 0 | 0 | 0   | 1X, 1Y           |
| 0 | 1 | 0 | 0   | 2X, 2Y           |
| 1 | 1 | 0 | 0   | 3X, 3Y           |
| 0 | 0 | 1 | 0   | 4X, 4Y           |
| 1 | 0 | 1 | 0   | 5X, 5Y           |
| 0 | 1 | 1 | 0   | 6X, 6Y           |
| 1 | 1 | 1 | 0   | 7X, 7Y           |

APPLICATIONS INFORMATION

In applications where separate power sources are used to drive V<sub>DD</sub> and the signal inputs, the V<sub>DD</sub> current capability should exceed V<sub>DD</sub>/R<sub>L</sub> (R<sub>L</sub> = effective external load). This provision avoids permanent current flow or clamp action on the V<sub>DD</sub> supply when power is applied or removed from the MMC 4067 or MMC 4097.

When switching from one address to another, some of the ON periods of the channels of the multiplexers will overlap momentarily, which may be objectionable in certain applications. Also when a channel is turned on or off by an address input, there is a momentary conductive path from the channel to V<sub>SS</sub>, which will dump some charge from any capacitor connected to the input or output of the channel. The inhibit input turning on a channel will similarly dump some charge to V<sub>SS</sub>. The amount of charge dumped is mostly a function of the signal level above V<sub>SS</sub>. Typically, at V<sub>DD</sub>/V<sub>SS</sub> = 10V, a 100 pF capacitor connected to the input or output of the channel will lose 3-4% of its voltage at the moment the channel turns on or off. This loss of voltage is essentially independent of the address or inhibit signal transition time, if the transition time is less than 1-2 μs. When the inhibit signal turns a channel off, there is no charge dumping to V<sub>SS</sub>. Rather, there is a slight rise in the channel voltage level (65 mV typ.) due to capacitive coupling from inhibit input to channel input or output. Address inputs also couple some voltage steps onto the channel signal levels.

In certain applications, the external load-resistor current may include both V<sub>DD</sub> and signal-line components. To avoid drawing V<sub>DD</sub> current when switch current flows into the transmission gate inputs, the voltage drop across the bidirectional switch must not exceed 0.8 volt

# 8-INPUT NAND / AND GATE

## GENERAL DESCRIPTION

The MMC 4068 (intermediate or extended temperature range) are monolithic integrated circuit, available in 14-lead dual in-line plastic or ceramic package. The MMC 4068 NAND/AND gate provides the system designer with direct implementation of the positive-logic 8-input NAND and AND functions and supplements the existing family of COS/MOS gates.

## FEATURES

- Medium-speed operation —  $t_{PHL}$ ,  $t_{PLH}$  = 75 ns (typ.) at 10 V
- Buffered output

## ABSOLUTE MAXIMUM RATINGS

|            |  |  |                            |
|------------|--|--|----------------------------|
| $V_{DD}^*$ | Supply voltage: G and H types<br>E and F types   | -0.5 to 20<br>-0.5 to 18<br>-0.5 to $V_{DD}+0.5$ | V<br>V<br>V                |
| $V_i$      | Input voltage  |  | V                          |
| $I_i$      | DC input current (any one input)   |  | $\pm 10$ mA                |
| $P_{tot}$  | Total power dissipation (per package)<br>Dissipation per output transistor<br>for $T_A$ = full package-temperature range |  | 200 mW<br>100 mW           |
| $T_A$      | Operating temperature : G and H types<br>E and F types   | -55 to 125<br>-40 to 85                          | $^{\circ}C$<br>$^{\circ}C$ |
| $T_{stg}$  | Storage temperature  | -65 to 150                                       | $^{\circ}C$                |

\* All voltage values are referred to  $V_{SS}$  pin voltage

## RECOMMENDED OPERATING CONDITIONS

|            |  |                         |                            |
|------------|--|-------------------------|----------------------------|
| $V_{DD}^*$ | Supply voltage: G and H types<br>E and F types         | 3 to 18<br>3 to 15      | V<br>V                     |
| $V_i$      | Input voltage  | 0 to $V_{DD}$           | V                          |
| $T_A$      | Operating temperature : G and H types<br>E and F types | -55 to 125<br>-40 to 85 | $^{\circ}C$<br>$^{\circ}C$ |

## CONNECTION DIAGRAM

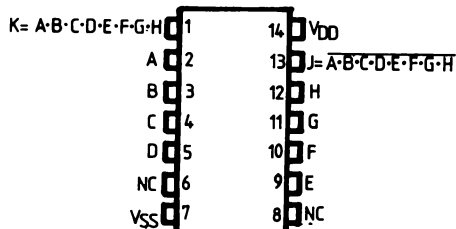

## STATIC ELECTRICAL CHARACTERISTICS

(over recommended operating conditions)

| PARAMETER       |                      | TEST CONDITIONS       |                       |                                 |                        | VALUES           |       |       |           |           |                   | UNIT          |           |         |         |         |
|-----------------|----------------------|-----------------------|-----------------------|---------------------------------|------------------------|------------------|-------|-------|-----------|-----------|-------------------|---------------|-----------|---------|---------|---------|
|                 |                      | V <sub>I</sub><br>(V) | V <sub>O</sub><br>(V) | I <sub>ol</sub>  <br>( $\mu$ A) | V <sub>DD</sub><br>(V) | T <sub>LOW</sub> |       | 25°C  |           |           | T <sub>HIGH</sub> |               |           |         |         |         |
|                 |                      |                       |                       |                                 |                        | min.             | max.  | min.  | typ       | max.      | min.              |               | max.      |         |         |         |
| I <sub>L</sub>  | Quiescent current    | G, H types            | 0/ 5                  |                                 |                        | 5                |       | 0.25  |           | 0.01      | 0.25              |               | 7.5       | $\mu$ A |         |         |
|                 |                      |                       | 0/10                  |                                 |                        | 10               |       | 0.5   |           | 0.01      | 0.5               |               | 15        |         |         |         |
| 0/15            |                      |                       |                       |                                 | 15                     |                  | 1     |       | 0.01      | 1         |                   | 30            |           |         |         |         |
| 0/20            |                      |                       |                       |                                 | 20                     |                  | 5     |       | 0.02      | 5         |                   | 150           |           |         |         |         |
|                 | E, F types           | 0/ 5                  |                       |                                 | 5                      |                  | 1     |       | 0.01      | 1         |                   | 7.5           | $\mu$ A   |         |         |         |
| 0/10            |                      |                       |                       | 10                              |                        | 2                |       | 0.01  | 2         |           | 15                |               |           |         |         |         |
| 0/15            |                      |                       |                       | 15                              |                        | 4                |       | 0.01  | 4         |           | 30                |               |           |         |         |         |
| V <sub>OH</sub> | Output high voltage  |                       | 0/ 5                  |                                 | < 1                    | 5                | 4.95  |       | 4.95      |           |                   | 4.95          |           | V       |         |         |
|                 |                      |                       | 0/10                  |                                 | < 1                    | 10               | 9.95  |       | 9.95      |           |                   | 9.95          |           |         |         |         |
|                 |                      |                       | 0/15                  |                                 | < 1                    | 15               | 14.95 |       | 14.95     |           |                   | 14.95         |           |         |         |         |
| V <sub>OL</sub> | Output low voltage   |                       | 5 / 0                 |                                 | < 1                    | 5                |       |       |           |           | 0.05              |               | 0.05      | V       |         |         |
|                 |                      |                       | 10/0                  |                                 | < 1                    | 10               |       |       |           |           | 0.05              |               | 0.05      |         |         |         |
|                 |                      |                       | 15/0                  |                                 | < 1                    | 15               |       |       |           |           | 0.05              |               | 0.05      |         |         |         |
| V <sub>IH</sub> | Input high voltage   |                       |                       | 0.5/4.5                         | < 1                    | 5                | 3.5   |       | 3.5       |           |                   | 3.5           |           | V       |         |         |
|                 |                      |                       |                       | 1/9                             | < 1                    | 10               | 7     |       | 7         |           |                   | 7             |           |         |         |         |
|                 |                      |                       |                       | 1.5/13.5                        | < 1                    | 15               | 11    |       | 11        |           |                   | 11            |           |         |         |         |
| V <sub>IL</sub> | Input low voltage    |                       |                       | 4.5/0.5                         | < 1                    | 5                |       |       |           |           | 1.5               |               | 1.5       | V       |         |         |
|                 |                      |                       |                       | 9/1                             | < 1                    | 10               |       |       |           |           | 3                 |               | 3         |         |         |         |
|                 |                      |                       |                       | 13.5/1.5                        | < 1                    | 15               |       |       |           |           | 4                 |               | 4         |         |         |         |
| I <sub>OH</sub> | Output drive current | G, H types            | 0/ 5                  | 2.5                             |                        | 5                | -2    |       | -1.6      | -3.2      |                   | -1.15         |           | mA      |         |         |
|                 |                      |                       | 0/ 5                  | 4.6                             |                        | 5                | -0.64 |       | -0.51     | -1        |                   | -0.36         |           |         |         |         |
| 0/10            |                      |                       | 9.5                   |                                 | 10                     | -1.6             |       | -1.3  | -2.6      |           | -0.9              |               |           |         |         |         |
| 0/15            |                      |                       | 13.5                  |                                 | 15                     | -4.2             |       | -3.4  | -6.8      |           | -2.4              |               |           |         |         |         |
|                 |                      | E, F types            | 0/ 5                  | 2.5                             |                        | 5                | -1.53 |       | -1.36     | -3.2      |                   | -1.1          |           |         |         |         |
| 0/ 5            |                      |                       | 4.6                   |                                 | 5                      | -0.52            |       | -0.44 | -1        |           | -0.36             |               |           |         |         |         |
| 0/10            |                      |                       | 9.5                   |                                 | 10                     | -1.3             |       | -1.1  | -2.6      |           | -0.9              |               |           |         |         |         |
| 0/15            |                      |                       | 13.5                  |                                 | 15                     | -3.6             |       | -3.0  | -6.8      |           | -2.4              |               |           |         |         |         |
| I <sub>OL</sub> | Output sink current  | G, H types            | 0/ 5                  | 0.4                             |                        | 5                | 0.64  |       | 0.51      | 1         |                   | 0.36          |           | mA      |         |         |
|                 |                      |                       | 0/10                  | 0.5                             |                        | 10               | 1.6   |       | 1.3       | 2.6       |                   | 0.9           |           |         |         |         |
| 0/15            |                      |                       | 1.5                   |                                 | 15                     | 4.2              |       | 3.4   | 6.8       |           | 2.4               |               |           |         |         |         |
|                 |                      | E, F types            | 0/ 5                  | 0.4                             |                        | 5                | 0.52  |       | 0.44      | 1         |                   | 0.36          |           |         |         |         |
| 0/10            |                      |                       | 0.5                   |                                 | 10                     | 1.3              |       | 1.1   | 2.6       |           | 0.9               |               |           |         |         |         |
| 0/15            |                      |                       | 1.5                   |                                 | 15                     | 3.6              |       | 3.0   | 6.8       |           | 2.4               |               |           |         |         |         |
|                 |                      |                       | G, H types            | 0/18                            | Any input              |                  | 18    |       | $\pm 0.1$ |           | $\pm 10^{-5}$     | $\pm 0.1$     |           |         | $\pm 1$ | $\mu$ A |
|                 |                      |                       |                       | E, F types                      |                        | 0/15             |       | 15    |           | $\pm 0.3$ |                   | $\pm 10^{-5}$ | $\pm 0.3$ |         |         |         |
| C <sub>I</sub>  | Input capacitance    |                       |                       |                                 | Any input              |                  |       |       |           | 5         | 7.5               |               |           | pF      |         |         |

\* T<sub>LOW</sub> = -55°C for G, H devices; -40°C for E, F devices.\* T<sub>HIGH</sub> = +125°C for G, H devices; +85°C for E, F devices.

The Noise Margin for both "1" and "0" level is:

1 V min. with V<sub>DD</sub> = 5 V2 V min. with V<sub>DD</sub> = 10 V2.5 V min. with V<sub>DD</sub> = 15 V

**DYNAMIC ELECTRICAL CHARACTERISTICS**

( $T_A = 25^\circ\text{C}$ ,  $C_L = 50\text{ pF}$ ,  $R_L = 200\text{ kohm}$ , typical temperature coefficient for all  $V_{DD} = 0.3\%/^\circ\text{C}$ , all input rise and fall times = 20 ns).

| PARAMETER              |                        | TEST CONDITIONS |              | VALUES |      |      | UNIT |
|------------------------|------------------------|-----------------|--------------|--------|------|------|------|
|                        |                        |                 | $V_{DD}$ (V) | min.   | typ. | max. |      |
| $t_{PHL}$<br>$t_{PLH}$ | Propagation delay time |                 | 5            |        | 150  | 300  | ns   |
|                        |                        |                 | 10           |        | 75   | 150  |      |
|                        |                        |                 | 15           |        | 55   | 110  |      |
| $t_{TLH}$<br>$t_{THL}$ | Transition time        |                 | 5            |        | 100  | 200  | ns   |
|                        |                        |                 | 10           |        | 50   | 100  |      |
|                        |                        |                 | 15           |        | 40   | 80   |      |



# HEX INVERTER

## GENERAL DESCRIPTION

The MMC 4069 is a monolithic integrated circuit processed in standard Al-gate CMOS technology. The MMC 4069 consists of six CMOS inverter circuits. This device is intended for all general-purpose inverter applications where the medium-power TTL-drive and logic-level-conversion capabilities of circuits such as MMC 4049 Hex Inverter/Buffer are not required.

## FEATURES

- Medium-speed operation  
 $t_{PHL}, t_{PLH} = 30 \text{ ns (typ.) at } 10 \text{ V}$
- Quiescent current specified to 20 V
- 5 V, 10 V, 15 V parametric ratings

## ABSOLUTE MAXIMUM RATINGS

|            |  |  |               |    |
|------------|--|--|---------------|----|
| $V_{DD}^*$ | Supply voltage: G and H types<br>E and F types   | -0.5 to 20<br>-0.5 to 18<br>-0.5 to $V_{DD}+0.5$ | 20<br>18<br>V | V  |
| $V_i$      | Input voltage  |  | $V_{DD}+0.5$  | V  |
| $I_i$      | DC input current (any one input)   |  | $\pm 10$      | mA |
| $P_{tot}$  | Total power dissipation (per package)<br>Dissipation per output transistor<br>for $T_A =$ full package-temperature range |  | 200           | mW |
| $T_A$      | Operating temperature :  |  | 100           | mW |
|            | G and H types  | -55 to   | 125           | °C |
|            | E and F types  | -40 to   | 85            | °C |
| $T_{stg}$  | Storage temperature  | -65 to   | 150           | °C |

\* All voltage values are referred to  $V_{SS}$  pin voltage

## RECOMMENDED OPERATING CONDITIONS

|            |  |                    |          |    |
|------------|--|--------------------|----------|----|
| $V_{DD}^*$ | Supply voltage: G and H types<br>E and F types | 3 to 18<br>3 to 15 | 18<br>15 | V  |
| $V_i$      | Input voltage                                  | 0 to               | $V_{DD}$ | V  |
| $T_A$      | Operating temperature :                        |                    |          |    |
|            | G and H types                                  | -55 to             | 125      | °C |
|            | E and F types                                  | -40 to             | 85       | °C |

## CONNECTION DIAGRAM

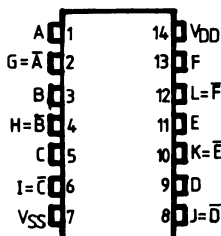

## SCHEMATIC DIAGRAM

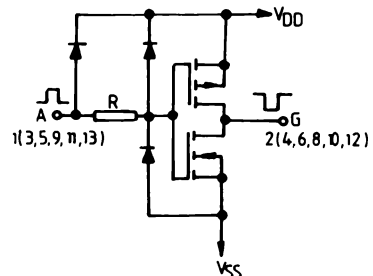

**STATIC ELECTRICAL CHARACTERISTICS**

(over recommended operating conditions)

| PARAMETER                       |                       |            | TEST CONDITIONS       |                            |                                |                        | VALUES                |                      |                       |                        |                       |                      | UNIT    |      |
|---------------------------------|-----------------------|------------|-----------------------|----------------------------|--------------------------------|------------------------|-----------------------|----------------------|-----------------------|------------------------|-----------------------|----------------------|---------|------|
|                                 |                       |            | V <sub>I</sub><br>(V) | V <sub>O</sub><br>(V)      | I <sub>O</sub>  <br>( $\mu$ A) | V <sub>DD</sub><br>(V) | T <sub>LOW</sub>      |                      | 25°C                  |                        |                       | T <sub>HIGH</sub>    |         |      |
|                                 |                       |            |                       |                            |                                |                        | min.                  | max.                 | min.                  | typ                    | max.                  | min.                 |         | max. |
| I <sub>L</sub>                  | Quiescent current     | G, H types | 0/ 5                  |                            |                                | 5                      |                       | 0.25                 |                       | 0.01                   | 0.25                  |                      | 7.5     |      |
|                                 |                       |            | 0/10                  |                            |                                | 10                     |                       | 0.5                  |                       | 0.01                   | 0.5                   |                      | 15      |      |
|                                 |                       |            | 0/15                  |                            |                                | 15                     |                       | 1                    |                       | 0.01                   | 1                     |                      | 30      |      |
|                                 |                       |            | 0/20                  |                            |                                | 20                     |                       | 5                    |                       | 0.02                   | 5                     |                      | 150     |      |
|                                 | E, F types            | 0/ 5       |                       |                            | 5                              |                        | 1                     |                      | 0.01                  | 1                      |                       | 7.5                  |         |      |
|                                 |                       | 0/10       |                       |                            | 10                             |                        | 2                     |                      | 0.01                  | 2                      |                       | 15                   |         |      |
| 0/15                            |                       |            |                       | 15                         |                                | 4                      |                       | 0.01                 | 4                     |                        | 30                    |                      |         |      |
| V <sub>OH</sub>                 | Output high voltage   |            | 0/ 5<br>0/10<br>0/15  |                            | < 1<br>< 1<br>< 1              | 5<br>10<br>15          | 4.95<br>9.95<br>14.95 |                      | 4.95<br>9.95<br>14.95 |                        | 4.95<br>9.95<br>14.95 |                      | V       |      |
| V <sub>OL</sub>                 | Output low voltage    |            | 5 /0<br>10/0<br>15/0  |                            | < 1<br>< 1<br>< 1              | 5<br>10<br>15          |                       | 0.05<br>0.05<br>0.05 |                       | 0.05<br>0.05<br>0.05   |                       | 0.05<br>0.05<br>0.05 | V       |      |
| V <sub>IH</sub>                 | Input high voltage    |            |                       | 0.5/4.5<br>1/9<br>1.5/13.5 | < 1<br>< 1<br>< 1              | 5<br>10<br>15          | 4<br>8<br>12.5        |                      | 4<br>8<br>12.5        |                        | 4<br>8<br>12.5        |                      | V       |      |
| V <sub>IL</sub>                 | Input low voltage     |            |                       | 4.5/0.5<br>9/1<br>13.5/1.5 | < 1<br>< 1<br>< 1              | 5<br>10<br>15          |                       | 1<br>2<br>2.5        |                       | 1<br>2<br>2.5          |                       | 1<br>2<br>2.5        | V       |      |
| I <sub>OH</sub>                 | Output drive current  | G, H types | 0/ 5                  | 2.5                        |                                | 5                      | -2                    |                      | -1.6                  | -3.2                   |                       | -1.15                |         |      |
|                                 |                       |            | 0/ 5                  | 4.6                        |                                | 5                      | -0.64                 |                      | -0.51                 | -1                     |                       | -0.36                |         |      |
|                                 |                       |            | 0/10                  | 9.5                        |                                | 10                     | -1.6                  |                      | -1.3                  | -2.6                   |                       | -0.9                 |         |      |
|                                 |                       |            | 0/15                  | 13.5                       |                                | 15                     | -4.2                  |                      | -3.4                  | -6.8                   |                       | -2.4                 |         |      |
|                                 |                       | E, F types | 0/ 5                  | 2.5                        |                                | 5                      | -1.53                 |                      | -1.36                 | -3.2                   |                       | -1.1                 |         |      |
|                                 |                       |            | 0/ 5                  | 4.6                        |                                | 5                      | -0.52                 |                      | -0.44                 | -1                     |                       | -0.36                |         |      |
| 0/10                            | 9.5                   |            |                       | 10                         | -1.3                           |                        | -1.1                  | -2.6                 |                       | -0.9                   |                       |                      |         |      |
| 0/15                            | 13.5                  |            | 15                    | -3.6                       |                                | -3.0                   | -6.8                  |                      | -2.4                  |                        |                       |                      |         |      |
| I <sub>OL</sub>                 | Output sink current   | G, H types | 0/ 5                  | 0.4                        |                                | 5                      | 0.64                  |                      | 0.51                  | 1                      |                       | 0.36                 |         |      |
|                                 |                       |            | 0/10                  | 0.5                        |                                | 10                     | 1.6                   |                      | 1.3                   | 2.6                    |                       | 0.9                  |         |      |
|                                 |                       |            | 0/15                  | 1.5                        |                                | 15                     | 4.2                   |                      | 3.4                   | 6.8                    |                       | 2.4                  |         |      |
|                                 |                       | E, F types | 0/ 5                  | 0.4                        |                                | 5                      | 0.52                  |                      | 0.44                  | 1                      |                       | 0.36                 |         |      |
|                                 |                       |            | 0/10                  | 0.5                        |                                | 10                     | 1.3                   |                      | 1.1                   | 2.6                    |                       | 0.9                  |         |      |
|                                 |                       |            | 0/15                  | 1.5                        |                                | 15                     | 3.6                   |                      | 3.0                   | 6.8                    |                       | 2.4                  |         |      |
| I <sub>IH</sub> I <sub>IL</sub> | Input leakage current | G, H types | 0/18                  | Any input                  |                                | 18                     |                       | $\pm$ 0.1            |                       | $\pm$ 10 <sup>-5</sup> | $\pm$ 0.1             |                      | $\pm$ 1 |      |
|                                 |                       | E, F types | 0/15                  |                            |                                | 15                     |                       | $\pm$ 0.3            |                       | $\pm$ 10 <sup>-5</sup> | $\pm$ 0.3             |                      | $\pm$ 1 |      |
| C <sub>I</sub>                  | Input capacitance     |            |                       | Any input                  |                                |                        |                       |                      | 5                     | 7.5                    |                       |                      | pF      |      |

\* T<sub>LOW</sub> = -55°C for G, H devices; -40°C for E, F devices.

\* T<sub>HIGH</sub> = +125°C for G, H devices; +85°C for E, F devices.

The Noise Margin for both "1" and "0" level is:

- 1 V min. with V<sub>DD</sub> = 5 V
- 2 V min. with V<sub>DD</sub> = 10 V
- 2.5 V min. with V<sub>DD</sub> = 15 V

**DYNAMIC ELECTRICAL CHARACTERISTICS**

( $T_A = 25^\circ\text{C}$ ,  $C_L = 50\text{ pF}$ ,  $R_L = 200\text{ kohm}$ , typical temperature coefficient for all  $V_{DD} = 0.3\%/^\circ\text{C}$  values, all input rise and fall times = 20 ns).

| PARAMETER                                       | TEST CONDITIONS | VALUES |      |      | UNIT |
|---|-----------------|--------|------|------|------|
|   | $V_{DD}$ (V)    | min.   | typ. | max. |      |
| $t_{PLH}$ : Propagation delay time<br>$t_{PHL}$ | 5               |        | 55   | 110  | ns   |
|   | 10              |        | 30   | 60   |      |
|   | 15              |        | 25   | 50   |      |
| $t_{TLH}$ : Transition time<br>$t_{THL}$        | 5               |        | 100  | 200  | ns   |
|   | 10              |        | 50   | 100  |      |
|   | 15              |        | 40   | 80   |      |

# QUAD EXCLUSIVE-OR GATE 4070 QUAD EXCLUSIVE-NOR GATE 4077

## GENERAL DESCRIPTION

The MMC 4070/4077 are monolithic integrated circuits, available in 14-lead dual in-line plastic or ceramic package.  
The MMC 4070 contains four independent exclusive-OR gates.  
The MMC 4077 contains four independent exclusive-NOR gates.  
The MMC 4070 and MMC 4077 provide the system designer with a means for direct implementation of exclusive-OR and exclusive-NOR function, respectively.

## FEATURES

- Medium-speed operation  $t_{pHL} = t_{pLH} = 65$  ns (TYP.) at  $V_{DD} = 10$  V,  $C_L = 50$  pF
- 100% tested for quiescent current

## APPLICATIONS

- Logical comparators
- Adders/subtractors
- Parity generators and checkers

## ABSOLUTE MAXIMUM RATINGS

|            |  |                               |                            |             |
|------------|--|-------------------------------|----------------------------|-------------|
| $V_{DD}^*$ | Supply voltage: G and H types<br>E and F types   | -0.5 to<br>-0.5 to<br>-0.5 to | 20<br>18<br>$V_{DD} + 0.5$ | V<br>V<br>V |
| $V_i$      | Input voltage  |                               |                            |             |
| $I_i$      | DC input current (any one input)   |                               | $\pm 10$                   | mA          |
| $P_{tot}$  | Total power dissipation (per package)<br>Dissipation per output transistor<br>for $T_A =$ full package-temperature range |                               | 200                        | mW          |
| $T_A$      | Operating temperature :  |                               | 100                        | mW          |
|            | G and H types  | -55 to                        | 125                        | °C          |
|            | E and F types  | -40 to                        | 85                         | °C          |
| $T_{stg}$  | Storage temperature  | -65 to                        | 150                        | °C          |

\* All voltage values are referred to  $V_{SS}$  pin voltage

## RECOMMENDED OPERATING CONDITIONS

|            |  |                      |                      |             |
|------------|--|----------------------|----------------------|-------------|
| $V_{DD}^*$ | Supply voltage: G and H types<br>E and F types | 3 to<br>3 to<br>0 to | 18<br>15<br>$V_{DD}$ | V<br>V<br>V |
| $V_i$      | Input voltage                                  |                      |                      |             |
| $T_A$      | Operating temperature :                        |                      |                      |             |
|            | G and H types                                  | -55 to               | 125                  | °C          |
|            | E and F types                                  | -40 to               | 85                   | °C          |

## CONNECTION DIAGRAM

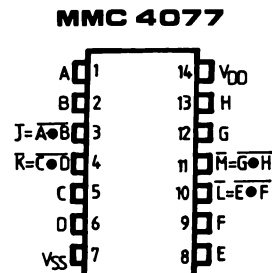
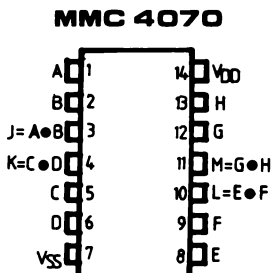

**STATIC ELECTRICAL CHARACTERISTICS**

(over recommended operating conditions)

| PARAMETER                         |                       |            | TEST CONDITIONS       |                            |                                |                        | VALUES                |                      |                       |                        |                       |                      | UNIT    |      |
|-----------------------------------|-----------------------|------------|-----------------------|----------------------------|--------------------------------|------------------------|-----------------------|----------------------|-----------------------|------------------------|-----------------------|----------------------|---------|------|
|                                   |                       |            | V <sub>I</sub><br>(V) | V <sub>O</sub><br>(V)      | I <sub>O</sub>  <br>( $\mu$ A) | V <sub>DD</sub><br>(V) | T <sub>LOW</sub> *    |                      | 25°C                  |                        |                       | T <sub>HIGH</sub> *  |         |      |
|                                   |                       |            |                       |                            |                                |                        | min.                  | max.                 | min.                  | typ                    | max.                  | min.                 |         | max. |
| I <sub>L</sub>                    | Quiescent current     | G, H types | 0/ 5                  |                            |                                | 5                      |                       | 1                    |                       | 0.02                   | 1                     |                      | 30      |      |
|                                   |                       |            | 0/10                  |                            |                                | 10                     |                       | 2                    |                       | 0.02                   | 2                     |                      | 60      |      |
|                                   |                       |            | 0/15                  |                            |                                | 15                     |                       | 4                    |                       | 0.02                   | 4                     |                      | 120     |      |
|                                   |                       |            | 0/20                  |                            |                                | 20                     |                       | 20                   |                       | 0.04                   | 20                    |                      | 600     |      |
|                                   | E, F types            | 0/ 5       |                       |                            | 5                              |                        | 4                     |                      | 0.02                  | 4                      |                       | 30                   |         |      |
|                                   |                       | 0/10       |                       |                            | 10                             |                        | 8                     |                      | 0.02                  | 8                      |                       | 60                   |         |      |
| 0/15                              |                       |            |                       | 15                         |                                | 16                     |                       | 0.02                 | 16                    |                        | 120                   |                      |         |      |
| V <sub>OH</sub>                   | Output high voltage   |            | 0/ 5<br>0/10<br>0/15  |                            | < 1<br>< 1<br>< 1              | 5<br>10<br>15          | 4.95<br>9.95<br>14.95 |                      | 4.95<br>9.95<br>14.95 |                        | 4.95<br>9.95<br>14.95 |                      | V       |      |
| V <sub>OL</sub>                   | Output low voltage    |            | 5 /0<br>10/0<br>15/0  |                            | < 1<br>< 1<br>< 1              | 5<br>10<br>15          |                       | 0.05<br>0.05<br>0.05 |                       | 0.05<br>0.05<br>0.05   |                       | 0.05<br>0.05<br>0.05 |         | V    |
| V <sub>IH</sub>                   | Input high voltage    |            |                       | 0.5/4.5<br>1/9<br>1.5/13.5 | < 1<br>< 1<br>< 1              | 5<br>10<br>15          | 3.5<br>7<br>11        |                      | 3.5<br>7<br>11        |                        | 3.5<br>7<br>11        |                      | V       |      |
| V <sub>IL</sub>                   | Input low voltage     |            |                       | 4.5/0.5<br>9/1<br>13.5/1.5 | < 1<br>< 1<br>< 1              | 5<br>10<br>15          |                       | 1.5<br>3<br>4        |                       | 1.5<br>3<br>4          |                       | 1.5<br>3<br>4        |         | V    |
| I <sub>OH</sub>                   | Output drive current  | G, H types | 0/ 5                  | 2.5                        |                                | 5                      | -2                    |                      | -1.6                  | -3.2                   |                       | -1.15                |         | mA   |
|                                   |                       |            | 0/ 5                  | 4.6                        |                                | 5                      | -0.64                 |                      | -0.51                 | -1                     |                       | -0.36                |         |      |
|                                   |                       |            | 0/10                  | 9.5                        |                                | 10                     | -1.6                  |                      | -1.3                  | -2.6                   |                       | -0.9                 |         |      |
|                                   |                       |            | 0/15                  | 13.5                       |                                | 15                     | -4.2                  |                      | -3.4                  | -6.8                   |                       | -2.4                 |         |      |
|                                   |                       | E, F types | 0/ 5                  | 2.5                        |                                | 5                      | -1.53                 |                      | -1.36                 | -3.2                   |                       | -1.1                 |         |      |
|                                   |                       |            | 0/ 5                  | 4.6                        |                                | 5                      | -0.52                 |                      | -0.44                 | -1                     |                       | -0.36                |         |      |
| 0/10                              | 9.5                   |            |                       | 10                         | -1.3                           |                        | -1.1                  | -2.6                 |                       | -0.9                   |                       |                      |         |      |
| 0/15                              | 13.5                  |            | 15                    | -3.6                       |                                | -3.0                   | -6.8                  |                      | -2.4                  |                        |                       |                      |         |      |
| I <sub>OL</sub>                   | Output sink current   | G, H types | 0/ 5                  | 0.4                        |                                | 5                      | 0.64                  |                      | 0.51                  | 1                      |                       | 0.36                 | mA      |      |
|                                   |                       |            | 0/10                  | 0.5                        |                                | 10                     | 1.6                   |                      | 1.3                   | 2.6                    |                       | 0.9                  |         |      |
|                                   |                       |            | 0/15                  | 1.5                        |                                | 15                     | 4.2                   |                      | 3.4                   | 6.8                    |                       | 2.4                  |         |      |
|                                   |                       | E, F types | 0/ 5                  | 0.4                        |                                | 5                      | 0.52                  |                      | 0.44                  | 1                      |                       | 0.36                 |         |      |
|                                   |                       |            | 0/10                  | 0.5                        |                                | 10                     | 1.3                   |                      | 1.1                   | 2.6                    |                       | 0.9                  |         |      |
|                                   |                       |            | 0/15                  | 1.5                        |                                | 15                     | 3.6                   |                      | 3.0                   | 6.8                    |                       | 2.4                  |         |      |
| I <sub>IH</sub> , I <sub>IL</sub> | Input leakage current | G, H types | 0/18                  | Any input                  |                                | 18                     |                       | $\pm$ 0.1            |                       | $\pm$ 10 <sup>-5</sup> | $\pm$ 0.1             |                      | $\pm$ 1 |      |
|                                   |                       | E, F types | 0/15                  |                            |                                | 15                     |                       | $\pm$ 0.3            |                       | $\pm$ 10 <sup>-5</sup> | $\pm$ 0.3             |                      | $\pm$ 1 |      |
| C <sub>I</sub>                    | Input capacitance     |            |                       | Any input                  |                                |                        |                       |                      | 5                     | 7.5                    |                       |                      | pF      |      |

\* T<sub>LOW</sub> = -55°C for G, H devices; -40°C for E, F devices.

\* T<sub>HIGH</sub> = +125°C for G, H devices; +85°C for E, F devices.

The Noise Margin for both "1" and "0" level is:

- 1 V min. with V<sub>DD</sub> = 5 V
- 2 V min. with V<sub>DD</sub> = 10 V
- 2.5 V min. with V<sub>DD</sub> = 15 V

**DYNAMIC ELECTRICAL CHARACTERISTICS**

( $T_A = 25^\circ\text{C}$ ,  $C_L = 50\text{ pF}$ ,  $R_L = 200\text{ k}\Omega$ , typical temperature coefficient for all  $V_{DD}$  values is  $0.3\%/^\circ\text{C}$ , all input rise and fall times =  $20\text{ ns}$ )

| PARAMETER              | TEST CONDITIONS        |               | VALUES |                 |                   | UNIT |
|------------------------|------------------------|---------------|--------|-----------------|-------------------|------|
|                        |                        | $V_{CC}(V)$   | MIN.   | TYP.            | MAX.              |      |
| $t_{PHL}$<br>$t_{PLH}$ | Propagation delay time | 5<br>10<br>15 |        | 140<br>65<br>50 | 280<br>130<br>100 | ns   |
| $t_{THL}$<br>$t_{TLH}$ | Transition time        | 5<br>10<br>15 |        | 100<br>50<br>40 | 200<br>100<br>80  | ns   |

**TRUTH TABLE**

(1 of 4 gates)

for 4070

| A | B | J |
|---|---|---|
| 0 | 0 | 0 |
| 1 | 0 | 1 |
| 0 | 1 | 1 |
| 1 | 1 | 0 |

Where 1 = High level  
0 = Low level  
 $J = A \oplus B$

**FUNCTIONAL DIAGRAM**

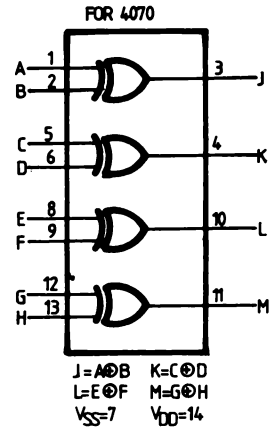

for 4077

| A | B | J |
|---|---|---|
| 0 | 0 | 1 |
| 1 | 0 | 0 |
| 0 | 1 | 0 |
| 1 | 1 | 1 |

Where 1 = High level  
0 = Low level  
 $J = A \oplus B$

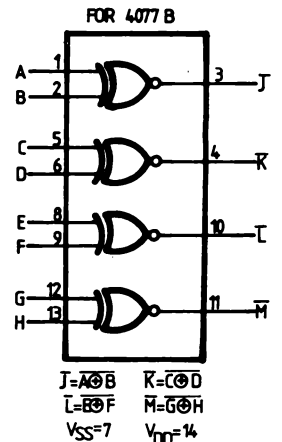

# OR Gates: QUAD 2 INPUT MMC 4071 DUAL 4 INPUT MMC 4072 TRIPLE 3 INPUT MMC 4075

## GENERAL DESCRIPTION

These OR gates are monolithic complementary MOS (CMOS) integrated circuits. The N and P channel enhancement mode transistors provide a symmetrical circuit with output swings essentially equal to the supply voltage. This results in high noise immunity over a wide supply voltage range. No DC power other than that caused by leakage current is consumed during static conditions. All inputs are protected against static discharge and latching conditions. The MMC 4071 MMC 4072 and MMC 4075E/F/G/H types are supplied in 14-lead hermetic dual-in-line ceramic or plastic packages.

The MMC 4071 MMC 4072 and MMC 4075E/F/G/H/G/H/OR gates provide the system designer with direct implementation of the OR function. All inputs and outputs are buffered.

The MMC 4071 MMC 4072 and MMC 4075E/F/G/H types are supplied in 14-lead hermetic dual-in-line ceramic or plastic packages.

## FEATURES

- Medium-Speed Operation- $t_{PLH}$ ,  $t_{PLH} = 60$  ns (typ.) at  $V_{DD} = 10$  V
- 100% tested for quiescent current

## ABSOLUTE MAXIMUM RATINGS

|            |  |                                     |                            |                |
|------------|--|-------------------------------------|----------------------------|----------------|
| $V_{DD}^*$ | Supply voltage: G and H types<br>E and F types   | -0.5 to 20<br>-0.5 to 18<br>-0.5 to | 20<br>18<br>$V_{DD} + 0.5$ | V<br>V<br>V    |
| $V_i$      | Input voltage  |                                     |                            | V              |
| $I_i$      | DC input current (any one input)   |                                     | $\pm 10$                   | mA             |
| $P_{tot}$  | Total power dissipation (per package)<br>Dissipation per output transistor<br>for $T_A =$ full package-temperature range |                                     | 200<br>100                 | mW<br>mW       |
| $T_A$      | Operating temperature : G and H types<br>E and F types   | -55 to<br>-40 to<br>-65 to          | 125<br>85<br>150           | °C<br>°C<br>°C |
| $T_{stg}$  | Storage temperature  |                                     |                            | °C             |

\* All voltage values are referred to  $V_{SS}$  pin voltage

## RECOMMENDED OPERATING CONDITIONS

|            |  |                      |                      |             |
|------------|--|----------------------|----------------------|-------------|
| $V_{DD}^*$ | Supply voltage: G and H types<br>E and F types         | 3 to<br>3 to<br>0 to | 18<br>15<br>$V_{DD}$ | V<br>V<br>V |
| $V_i$      | Input voltage  |                      |                      | V           |
| $T_A$      | Operating temperature : G and H types<br>E and F types | -55 to<br>-40 to     | 125<br>85            | °C<br>°C    |

## CONNECTION DIAGRAM

MMC 4071

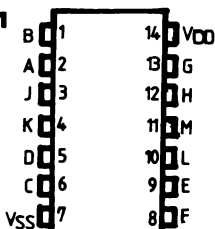

$$\begin{aligned} J &= A + B \\ K &= C + D \\ L &= E + F \\ M &= G + H \end{aligned}$$

MMC 4072

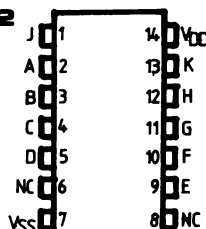

$$\begin{aligned} J &= A + B + C + D \\ K &= E + F + G + H \end{aligned}$$

MMC 4075

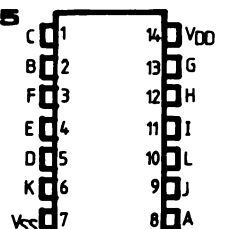

$$\begin{aligned} J &= A + B + C \\ K &= D + E + F \\ L &= G + H + I \end{aligned}$$

**STATIC ELECTRICAL CHARACTERISTICS**

(over recommended operating conditions)

| PARAMETER                       |                       | TEST CONDITIONS       |                       |                          |                        | VALUES             |       |       |                   |      |                     | UNIT  |      |
|---------------------------------|-----------------------|-----------------------|-----------------------|--------------------------|------------------------|--------------------|-------|-------|-------------------|------|---------------------|-------|------|
|                                 |                       | V <sub>I</sub><br>(V) | V <sub>O</sub><br>(V) | I <sub>O</sub>  <br>(μA) | V <sub>DD</sub><br>(V) | T <sub>LOW</sub> * |       | 25°C  |                   |      | T <sub>HIGH</sub> * |       |      |
|                                 |                       |                       |                       |                          |                        | min.               | max.  | min.  | typ               | max. | min.                |       | max. |
| I <sub>L</sub>                  | Quiescent current     | G, H types            | 0/ 5                  |                          |                        | 5                  |       | 0.25  |                   | 0.01 | 0.25                |       | 7.5  |
|                                 |                       |                       | 0/10                  |                          |                        | 10                 |       | 0.5   |                   | 0.01 | 0.5                 |       | 15   |
|                                 |                       |                       | 0/15                  |                          |                        | 15                 |       | 1     |                   | 0.01 | 1                   |       | 30   |
|                                 |                       |                       | 0/20                  |                          |                        | 20                 |       | 5     |                   | 0.02 | 5                   |       | 150  |
|                                 | E, F types            | 0/ 5                  |                       |                          | 5                      |                    | 1     |       | 0.01              | 1    |                     | 7.5   |      |
|                                 |                       | 0/10                  |                       |                          | 10                     |                    | 2     |       | 0.01              | 2    |                     | 15    |      |
|                                 | 0/15                  |                       |                       | 15                       |                        | 4                  |       | 0.01  | 4                 |      | 30                  |       |      |
| V <sub>OH</sub>                 | Output high voltage   | 0/ 5                  |                       | < 1                      | 5                      | 4.95               |       | 4.95  |                   |      | 4.95                |       |      |
|                                 |                       | 0/10                  |                       | < 1                      | 10                     | 9.95               |       | 9.95  |                   |      | 9.95                |       |      |
|                                 |                       | 0/15                  |                       | < 1                      | 15                     | 14.95              |       | 14.95 |                   |      | 14.95               |       |      |
| V <sub>OL</sub>                 | Output low voltage    | 5 /0                  |                       | < 1                      | 5                      |                    | 0.05  |       |                   | 0.05 |                     | 0.05  |      |
|                                 |                       | 10/0                  |                       | < 1                      | 10                     |                    | 0.05  |       |                   | 0.05 |                     | 0.05  |      |
|                                 |                       | 15/0                  |                       | < 1                      | 15                     |                    | 0.05  |       |                   | 0.05 |                     | 0.05  |      |
| V <sub>IH</sub>                 | Input high voltage    |                       | 0.5/4.5               | < 1                      | 5                      | 3.5                |       | 3.5   |                   |      | 3.5                 |       |      |
|                                 |                       |                       | 1/9                   | < 1                      | 10                     | 7                  |       | 7     |                   |      | 7                   |       |      |
|                                 |                       |                       | 1.5/13.5              | < 1                      | 15                     | 11                 |       | 11    |                   |      | 11                  |       |      |
| V <sub>IL</sub>                 | Input low voltage     |                       | 4.5/0.5               | < 1                      | 5                      |                    | 1.5   |       |                   | 1.5  |                     | 1.5   |      |
|                                 |                       |                       | 9/1                   | < 1                      | 10                     |                    | 3     |       |                   | 3    |                     | 3     |      |
|                                 |                       |                       | 13.5/1.5              | < 1                      | 15                     |                    | 4     |       |                   | 4    |                     | 4     |      |
| I <sub>OH</sub>                 | Output drive current  | G, H types            | 0/ 5                  | 2.5                      |                        | 5                  | -2    |       | -1.6              | -3.2 |                     | -1.15 |      |
|                                 |                       |                       | 0/ 5                  | 4.6                      |                        | 5                  | -0.64 |       | -0.51             | -1   |                     | -0.36 |      |
|                                 |                       |                       | 0/10                  | 9.5                      |                        | 10                 | -1.6  |       | -1.3              | -2.6 |                     | -0.9  |      |
|                                 |                       |                       | 0/15                  | 13.5                     |                        | 15                 | -4.2  |       | -3.4              | -6.8 |                     | -2.4  |      |
|                                 |                       | E, F types            | 0/ 5                  | 2.5                      |                        | 5                  | -1.53 |       | -1.36             | -3.2 |                     | -1.1  |      |
|                                 |                       |                       | 0/ 5                  | 4.6                      |                        | 5                  | -0.52 |       | -0.44             | -1   |                     | -0.36 |      |
|                                 | 0/10                  | 9.5                   |                       | 10                       | -1.3                   |                    | -1.1  | -2.6  |                   | -0.9 |                     |       |      |
|                                 | 0/15                  | 13.5                  |                       | 15                       | -3.6                   |                    | -3.0  | -6.8  |                   | -2.4 |                     |       |      |
| I <sub>OL</sub>                 | Output sink current   | G, H types            | 0/ 5                  | 0.4                      |                        | 5                  | 0.64  |       | 0.51              | 1    |                     | 0.36  |      |
|                                 |                       |                       | 0/10                  | 0.5                      |                        | 10                 | 1.6   |       | 1.3               | 2.6  |                     | 0.9   |      |
|                                 |                       |                       | 0/15                  | 1.5                      |                        | 15                 | 4.2   |       | 3.4               | 6.8  |                     | 2.4   |      |
|                                 |                       | E, F types            | 0/ 5                  | 0.4                      |                        | 5                  | 0.52  |       | 0.44              | 1    |                     | 0.36  |      |
|                                 |                       |                       | 0/10                  | 0.5                      |                        | 10                 | 1.3   |       | 1.1               | 2.6  |                     | 0.9   |      |
|                                 |                       |                       | 0/15                  | 1.5                      |                        | 15                 | 3.6   |       | 3.0               | 6.8  |                     | 2.4   |      |
| I <sub>IH</sub> I <sub>IL</sub> | Input leakage current | G, H types            | 0/18                  | Any input                | 18                     |                    | ±0.1  |       | ±10 <sup>-5</sup> | ±0.1 |                     | ±1    |      |
|                                 |                       | E, F types            | 0/15                  |                          | 15                     |                    | ±0.3  |       | ±10 <sup>-5</sup> | ±0.3 |                     | ±1    |      |
| C <sub>I</sub>                  | Input capacitance     |                       | Any input             |                          |                        |                    |       |       | 5                 | 7.5  |                     | pF    |      |

\* T<sub>LOW</sub> = -55°C for G, H devices; -40°C for E, F devices.

\* T<sub>HIGH</sub> = +125°C for G, H devices; +85°C for E, F devices.

The Noise Margin for both "1" and "0" level is:

- 1 V min. with V<sub>DD</sub> = 5 V
- 2 V min. with V<sub>DD</sub> = 10 V
- 2.5 V min. with V<sub>DD</sub> = 15 V



**DYNAMIC ELECTRICAL CHARACTERISTICS**

( $T_A = 25^\circ\text{C}$ ,  $C_L = 50\text{ pF}$ ,  $R_L = 200\text{ kohm}$ , typical temperature coefficient for all  $V_{DD} = 0.3\%/^\circ\text{C}$  values, all input rise and fall times = 20 ns).

| PARAMETER                        | TEST CONDITIONS | VALUES       |      |      | UNIT |
|----------------------------------|-----------------|--------------|------|------|------|
|                                  |                 | $V_{DD}$ (V) | min. | typ. |      |
| $t_{PHL}$ Propagation delay time | 5               |              | 125  | 250  | ns   |
|                                  | 10              |              | 60   | 120  |      |
|                                  | 15              |              | 45   | 90   |      |
| $t_{PLH}$ Propagation delay time | 5               |              | 175  | 350  | ns   |
|                                  | 10              |              | 70   | 140  |      |
|                                  | 15              |              | 50   | 110  |      |
| $t_{THL}$ Transition time        | 5               |              | 100  | 200  | ns   |
|                                  | 10              |              | 50   | 100  |      |
|                                  | 15              |              | 40   | 80   |      |

**SCHEMATIC DIAGRAM**

**MMC 4071**

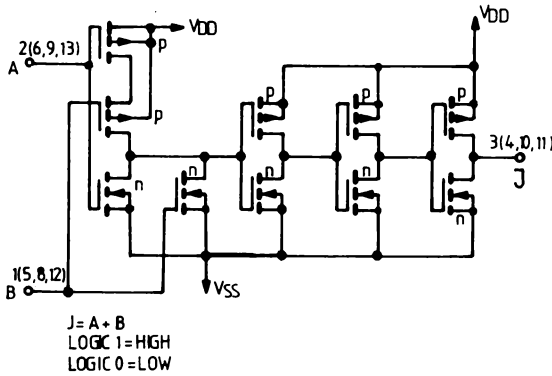

**MMC 4072**

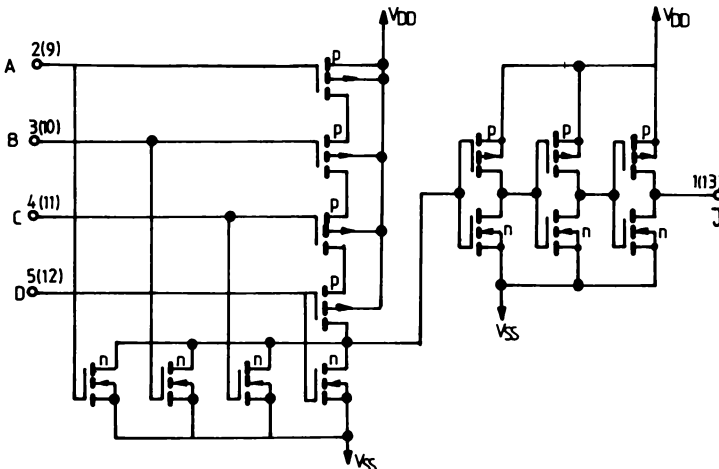

MMC 4075

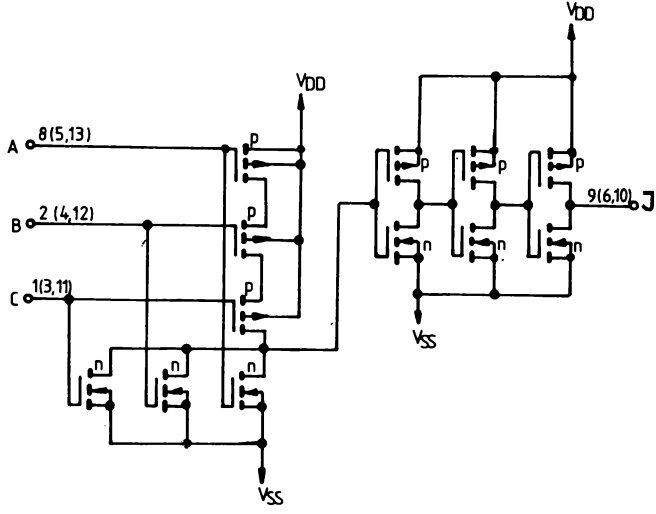

1 = HIGH LEVEL  
0 = LOW LEVEL

# 4BIT D-TYPE REGISTERS

## GENERAL DESCRIPTION

The MMC 4076 (intermediate or extended temperature range) are monolithic integrated circuit, available in 16-lead dual in-line plastic or ceramic package.

The MMC 4076 types are four-bit registers consisting of D-type flip-flops that feature three-state outputs. Data Disable inputs are provided to control the entry of data into the flip-flops. When both Data Disable inputs are low, data at the D inputs are loaded into their respective flip-flops on the next positive transition of the clock input. Output Disable inputs are also provided. When the Output Disable inputs are both low, the normal logic states of the four outputs are available to the load. The outputs are disabled independently of the clock by a high logic level at either Output Disable input, and present a high impedance.

## FEATURES

- Three-state outputs
- Input disabled without gating the clock
- Gated output control lines for enabling or disabling the outputs.

## ABSOLUTE MAXIMUM RATINGS

|            |   |  |   |
|------------|---|--|---|
| $V_{DD}^*$ | Supply voltage: G and H types<br>E and F types                                  | -0.5 to 20<br>-0.5 to 18<br>-0.5 to $V_{DD}+0.5$ | V<br>V<br>V                               |
| $V_i$      | Input voltage   |  | V   |
| $I_i$      | DC input current (any one input)  |  | $\pm 10$ mA                               |
| $P_{tot}$  | Total power dissipation (per package)   |  | 200 mW                                    |
|            | Dissipation per output transistor<br>for $T_A$ = full package-temperature range |  | 100 mW                                    |
| $T_A$      | Operating temperature : G and H types<br>E and F types                          | -55 to 125<br>-40 to 85<br>-65 to 150            | $^{\circ}C$<br>$^{\circ}C$<br>$^{\circ}C$ |
| $T_{stg}$  | Storage temperature   |  | $^{\circ}C$                               |

\* All voltage values are referred to  $V_{SS}$  pin voltage

## RECOMMENDED OPERATING CONDITIONS

|            |  |                         |                            |
|------------|--|-------------------------|----------------------------|
| $V_{DD}^*$ | Supply voltage: G and H types<br>E and F types         | 3 to 18<br>3 to 15      | V<br>V                     |
| $V_i$      | Input voltage  | 0 to $V_{DD}$           | V                          |
| $T_A$      | Operating temperature : G and H types<br>E and F types | -55 to 125<br>-40 to 85 | $^{\circ}C$<br>$^{\circ}C$ |

## CONNECTION DIAGRAM

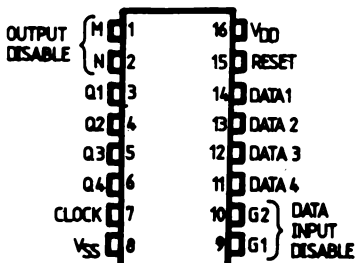

## TRUTH TABLE

| Reset | Clock | Data Input Disable<br>$G_1$ $G_2$ | Data<br>D | Next State Output<br>Q |    |
|-------|-------|-----------------------------------|-----------|------------------------|----|
| 1     | x     | x x                               | x         | 0                      |    |
| 0     | 0     | x x                               | x         | Q                      | NC |
| 0     | 0     | 1 x                               | x         | Q                      | NC |
| 0     | 0     | x 1                               | x         | Q                      | NC |
| 0     | 0     | 0 0                               | 1         | 1                      |    |
| 0     | 0     | 0 0                               | 0         | 0                      |    |
| 0     | 1     | x x                               | x         | Q                      | NC |
| 0     | 1     | x x                               | x         | Q                      | NC |

1 = High Level  
0 = Low Level

X = Don't Care  
NC = No Change

LOGIC DIAGRAM

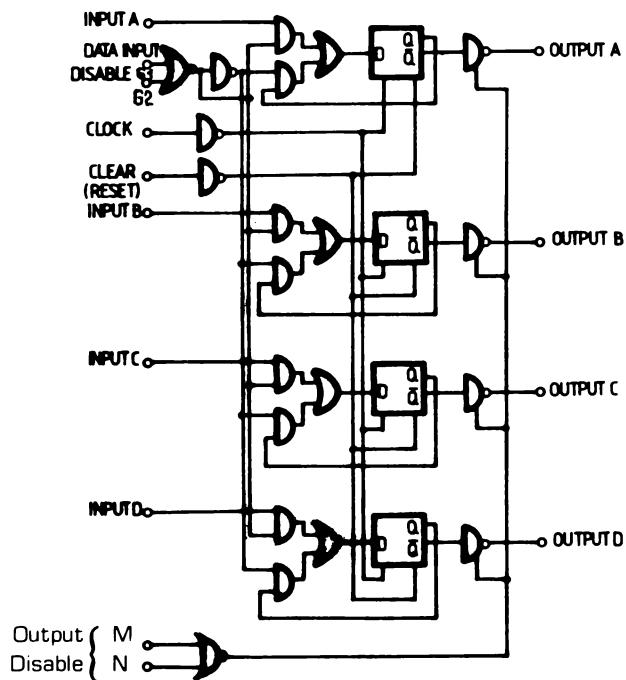

WAVEFORMS

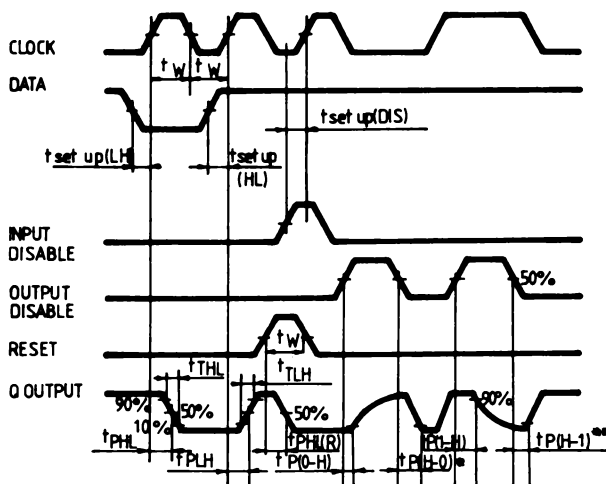

\* Output tied to  $V_{DD}$  trough 1 k $\Omega$   
 \*\* Output tied to  $V_{SS}$  trough 1 k $\Omega$

**STATIC ELECTRICAL CHARACTERISTICS**

(over recommended operating conditions)

| PARAMETER                         |                       |                      | TEST CONDITIONS            |                       |                                |                        | VALUES               |                       |               |           |                       |                   | UNIT    |      |
|-----------------------------------|-----------------------|----------------------|----------------------------|-----------------------|--------------------------------|------------------------|----------------------|-----------------------|---------------|-----------|-----------------------|-------------------|---------|------|
|                                   |                       |                      | V <sub>I</sub><br>(V)      | V <sub>O</sub><br>(V) | I <sub>O</sub>  <br>( $\mu$ A) | V <sub>DD</sub><br>(V) | T <sub>LOW</sub>     |                       | 25°C          |           |                       | T <sub>HIGH</sub> |         |      |
|                                   |                       |                      |                            |                       |                                |                        | min.                 | max.                  | min.          | typ       | max.                  | min.              |         | max. |
| I <sub>L</sub>                    | Quiescent current     | G, H types           | 0/ 5                       |                       |                                | 5                      |                      | 5                     |               | 0.04      | 5                     |                   | 150     |      |
|                                   |                       |                      | 0/10                       |                       |                                | 10                     |                      | 10                    |               | 0.04      | 10                    |                   | 300     |      |
|                                   |                       |                      | 0/15                       |                       |                                | 15                     |                      | 20                    |               | 0.04      | 20                    |                   | 600     |      |
|                                   |                       |                      | 0/20                       |                       |                                | 20                     |                      | 100                   |               | 0.08      | 100                   |                   | 3000    |      |
|                                   | E, F types            | 0/ 5                 |                            |                       | 5                              |                        | 20                   |                       | 0.04          | 20        |                       | 150               |         |      |
|                                   |                       | 0/10                 |                            |                       | 10                             |                        | 40                   |                       | 0.04          | 40        |                       | 300               |         |      |
| 0/15                              |                       |                      |                            | 15                    |                                | 80                     |                      | 0.04                  | 80            |           | 600                   |                   |         |      |
| V <sub>OH</sub>                   | Output high voltage   | 0/ 5<br>0/10<br>0/15 |                            | < 1<br>< 1<br>< 1     | 5<br>10<br>15                  | 4.95<br>9.95<br>14.95  |                      | 4.95<br>9.95<br>14.95 |               |           | 4.95<br>9.95<br>14.95 |                   | V       |      |
| V <sub>OL</sub>                   | Output low voltage    | 5 /0<br>10/0<br>15/0 |                            | < 1<br>< 1<br>< 1     | 5<br>10<br>15                  |                        | 0.05<br>0.05<br>0.05 |                       |               |           | 0.05<br>0.05<br>0.05  |                   | V       |      |
| V <sub>IH</sub>                   | Input high voltage    |                      | 0.5/4.5<br>1/9<br>1.5/13.5 | < 1<br>< 1<br>< 1     | 5<br>10<br>15                  | 3.5<br>7<br>11         |                      | 3.5<br>7<br>11        |               |           | 3.5<br>7<br>11        |                   | V       |      |
| V <sub>IL</sub>                   | Input low voltage     |                      | 4.5/0.5<br>9/1<br>13.5/1.5 | < 1<br>< 1<br>< 1     | 5<br>10<br>15                  |                        | 1.5<br>3<br>4        |                       |               |           | 1.5<br>3<br>4         |                   | V       |      |
| I <sub>OH</sub>                   | Output drive current  | G, H types           | 0/ 5                       | 2.5                   |                                | 5                      | -2                   |                       | -1.6          | -3.2      |                       | -1.15             |         | mA   |
|                                   |                       |                      | 0/ 5                       | 4.6                   |                                | 5                      | -0.64                |                       | -0.51         | -1        |                       | -0.36             |         |      |
|                                   |                       |                      | 0/10                       | 9.5                   |                                | 10                     | -1.6                 |                       | -1.3          | -2.6      |                       | -0.9              |         |      |
|                                   |                       | 0/15                 | 13.5                       |                       | 15                             | -4.2                   |                      | -3.4                  | -6.8          |           | -2.4                  |                   |         |      |
|                                   |                       | E, F types           | 0/ 5                       | 2.5                   |                                | 5                      | -1.53                |                       | -1.36         | -3.2      |                       | -1.1              |         |      |
|                                   |                       |                      | 0/ 5                       | 4.6                   |                                | 5                      | -0.52                |                       | -0.44         | -1        |                       | -0.36             |         |      |
| 0/10                              | 9.5                   |                      |                            | 10                    | -1.3                           |                        | -1.1                 | -2.6                  |               | -0.9      |                       |                   |         |      |
| 0/15                              | 13.5                  |                      | 15                         | -3.6                  |                                | -3.0                   | -6.8                 |                       | -2.4          |           |                       |                   |         |      |
| I <sub>OL</sub>                   | Output sink current   | G, H types           | 0/ 5                       | 0.4                   |                                | 5                      | 0.64                 |                       | 0.51          | 1         |                       | 0.36              |         | mA   |
|                                   |                       |                      | 0/10                       | 0.5                   |                                | 10                     | 1.6                  |                       | 1.3           | 2.6       |                       | 0.9               |         |      |
|                                   |                       |                      | 0/15                       | 1.5                   |                                | 15                     | 4.2                  |                       | 3.4           | 6.8       |                       | 2.4               |         |      |
|                                   |                       | E, F types           | 0/ 5                       | 0.4                   |                                | 5                      | 0.52                 |                       | 0.44          | 1         |                       | 0.36              |         |      |
|                                   |                       |                      | 0/10                       | 0.5                   |                                | 10                     | 1.3                  |                       | 1.1           | 2.6       |                       | 0.9               |         |      |
|                                   |                       |                      | 0/15                       | 1.5                   |                                | 15                     | 3.6                  |                       | 3.0           | 6.8       |                       | 2.4               |         |      |
| I <sub>IH</sub> , I <sub>IL</sub> | Input leakage current | G, H types           | 0/18                       | Any input             | 18                             |                        | $\pm 0.1$            |                       | $\pm 10^{-5}$ | $\pm 0.1$ |                       | $\pm 1$           | $\mu$ A |      |
|                                   |                       | E, F types           | 0/15                       |                       | 15                             |                        | $\pm 0.3$            |                       | $\pm 10^{-5}$ | $\pm 0.3$ |                       | $\pm 1$           |         |      |
| I <sub>OH</sub>                   | 3-state output        | G, H types           | 0/18                       | 0/18                  | 18                             |                        | $\pm 0.4$            |                       | $\pm 10^{-4}$ | $\pm 0.4$ |                       | $\pm 12$          | $\mu$ A |      |
|                                   |                       | E, F types           | 0/15                       | 0/15                  | 15                             |                        | $\pm 1.0$            |                       | $\pm 10^{-4}$ | $\pm 1.0$ |                       | $\pm 7.5$         |         |      |

| PARAMETER                        | TEST CONDITIONS       |                       |                          |                        | VALUES             |      |      |     |      |                     | UNIT |      |
|----------------------------------|-----------------------|-----------------------|--------------------------|------------------------|--------------------|------|------|-----|------|---------------------|------|------|
|                                  | V <sub>I</sub><br>(V) | V <sub>O</sub><br>(V) | I <sub>O</sub>  <br>(μA) | V <sub>DD</sub><br>(V) | T <sub>LOW</sub> * |      | 25°C |     |      | T <sub>HIGH</sub> * |      |      |
|                                  |                       |                       |                          |                        | Min.               | Max. | Min. | Typ | Max. | Min.                |      | Max. |
| C <sub>I</sub> Input capacitance |                       | Any input             |                          |                        |                    |      |      | 5   | 7.5  |                     |      | pF   |

\* T<sub>LOW</sub> = -55°C for G, H devices; -40°C for E, F devices.

\* T<sub>HIGH</sub> = +125°C for G, H devices; +85°C for E, F devices.

The Noise Margin for both "1" and "0" level is:

1 V min. with V<sub>DD</sub> = 5 V

2 V min. with V<sub>DD</sub> = 10 V

2.5 V min. with V<sub>DD</sub> = 15 V

**DYNAMIC ELECTRICAL CHARACTERISTICS**

(T<sub>A</sub> = 25°C, C<sub>L</sub> = 50 pF, R<sub>L</sub> = 200 kohm, typical temperature coefficient for all V<sub>DD</sub> values is 0.3%/°C, all input rise and fall times = 20 ns).

| PARAMETER  | TEST CONDITIONS       | VALUES              |              |              | UNIT          |      |
|--|-----------------------|---------------------|--------------|--------------|---------------|------|
|  |                       | V <sub>DD</sub> (V) | min.         | typ.         |               | max. |
| t <sub>PLH</sub> , t <sub>PHL</sub><br>Propagation delay time (clock to Q output)    |                       | 5, 10, 15           |              | 300, 125, 90 | 600, 250, 180 | ns   |
| t <sub>PHL(R)</sub><br>Propagation delay time (Reset)                                |                       | 5, 10, 15           |              | 230, 100, 75 | 460, 200, 150 | ns   |
| t <sub>P(1-H)</sub> , t <sub>P(0-H)</sub><br>3-state output 1 or 0 to high impedance | R <sub>L</sub> = 1 kΩ | 5, 10, 15           |              | 150, 75, 60  | 300, 150, 120 | ns   |
| t <sub>P(H-1)</sub> , t <sub>P(H-0)</sub><br>3-state high impedance to 1 or 0 output | R <sub>L</sub> = 1 kΩ | 5, 10, 15           |              | 150, 75, 60  | 300, 150, 120 | ns   |
| t <sub>TLH</sub> , t <sub>THL</sub><br>Transition time                               |                       | 5, 10, 15           |              | 100, 50, 40  | 200, 100, 80  | ns   |
| t <sub>w</sub><br>Clock pulse width  |                       | 5, 10, 15           | 200, 100, 80 | 100, 50, 40  |               | ns   |
| t <sub>w</sub><br>Reset pulse width  |                       | 5, 10, 15           | 120, 50, 40  | 60, 25, 20   |               | ns   |
| t <sub>setup</sub><br>Data setup time  |                       | 5, 10, 15           | 200, 80, 60  | 100, 40, 30  |               | ns   |
| t <sub>setup</sub><br>Data input disable setup time                                  |                       | 5, 10, 15           | 180, 100, 70 | 90, 50, 35   |               | ns   |
| f <sub>max</sub><br>Maximum clock frequency  |                       | 5, 10, 15           | 3, 6, 8      | 6, 12, 16    |               | MHz  |
| t <sub>r</sub> , t <sub>f</sub><br>Clock input rise or fall time                     |                       | 5, 10, 15           | 15, 5, 5     |              |               | μs   |

# 8-INPUT NOR/OR GATE

## GENERAL DESCRIPTION

The MMC 4078 (intermediate or extended temperature range) are monolithic integrated circuits available in 14-lead dual-in-line plastic or ceramic package.

The MMC 4078 NOR/OR Gate provides the system designer with direct implementation of the positive-logic-8-input NOR and OR function and supplements the existing family of COS/MOS gates.

## FEATURES

- Medium-speed operation  $t_{PHL}$ ,  $t_{PLH} = 75$  ns (typ.) at  $V_{DD} = 10$  V
- 100% tested for quiescent current

## ABSOLUTE MAXIMUM RATINGS

|            |  |                               |                          |                |
|------------|--|-------------------------------|--------------------------|----------------|
| $V_{DD}^*$ | Supply voltage: G and H types<br>E and F types   | -0.5 to<br>-0.5 to<br>-0.5 to | 20<br>18<br>$V_{DD}+0.5$ | V<br>V<br>V    |
| $V_i$      | Input voltage  |                               |                          |                |
| $I_i$      | DC input current (any one input)   |                               | $\pm 10$                 | mA             |
| $P_{tot}$  | Total power dissipation (per package)<br>Dissipation per output transistor<br>for $T_A =$ full package-temperature range |                               | 200                      | mW             |
| $T_A$      | Operating temperature : G and H types<br>E and F types   | -55 to<br>-40 to<br>-65 to    | 125<br>85<br>150         | °C<br>°C<br>°C |
| $T_{stg}$  | Storage temperature  |                               |                          |                |

\* All voltage values are referred to  $V_{SS}$  pin voltage

## RECOMMENDED OPERATING CONDITIONS

|            |  |                      |                      |             |
|------------|--|----------------------|----------------------|-------------|
| $V_{DD}^*$ | Supply voltage: G and H types<br>E and F types         | 3 to<br>3 to<br>0 to | 18<br>15<br>$V_{DD}$ | V<br>V<br>V |
| $V_i$      | Input voltage  |                      |                      |             |
| $T_A$      | Operating temperature : G and H types<br>E and F types | -55 to<br>-40 to     | 125<br>85            | °C<br>°C    |

## CONNECTION DIAGRAM

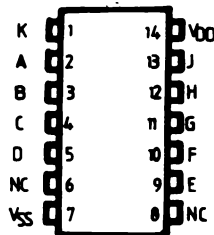

**STATIC ELECTRICAL CHARACTERISTICS**

(over recommended operating conditions)

| PARAMETER                       |                       | TEST CONDITIONS       |                       |                                |                        | VALUES             |       |           |       |                        |                     | UNIT  |         |         |
|---------------------------------|-----------------------|-----------------------|-----------------------|--------------------------------|------------------------|--------------------|-------|-----------|-------|------------------------|---------------------|-------|---------|---------|
|                                 |                       | V <sub>I</sub><br>(V) | V <sub>O</sub><br>(V) | I <sub>O</sub>  <br>( $\mu$ A) | V <sub>DD</sub><br>(V) | T <sub>LOW</sub> * |       | 25°C      |       |                        | T <sub>HIGH</sub> * |       |         |         |
|                                 |                       |                       |                       |                                |                        | min.               | max.  | min.      | typ   | max.                   | min.                |       | max.    |         |
| I <sub>L</sub>                  | Quiescent current     | G, H types            | 0/ 5                  |                                |                        | 5                  |       | 0.25      |       | 0.01                   | 0.25                |       | 7.5     | $\mu$ A |
|                                 |                       |                       | 0/10                  |                                |                        | 10                 |       | 0.5       |       | 0.01                   | 0.5                 |       | 15      |         |
|                                 |                       |                       | 0/15                  |                                |                        | 15                 |       | 1         |       | 0.01                   | 1                   |       | 30      |         |
|                                 |                       |                       | 0/20                  |                                |                        | 20                 |       | 5         |       | 0.02                   | 5                   |       | 150     |         |
|                                 |                       | E, F types            | 0/ 5                  |                                |                        | 5                  |       | 1         |       | 0.01                   | 1                   |       | 7.5     |         |
|                                 |                       |                       | 0/10                  |                                |                        | 10                 |       | 2         |       | 0.01                   | 2                   |       | 15      |         |
|                                 |                       |                       | 0/15                  |                                |                        | 15                 |       | 4         |       | 0.01                   | 4                   |       | 30      |         |
| V <sub>OH</sub>                 | Output high voltage   |                       | 0/ 5                  |                                | < 1                    | 5                  | 4.95  |           | 4.95  |                        |                     | 4.95  | V       |         |
|                                 |                       |                       | 0/10                  |                                | < 1                    | 10                 | 9.95  |           | 9.95  |                        |                     | 9.95  |         |         |
|                                 |                       |                       | 0/15                  |                                | < 1                    | 15                 | 14.95 |           | 14.95 |                        |                     | 14.95 |         |         |
| V <sub>OL</sub>                 | Output low voltage    |                       | 5 /0                  |                                | < 1                    | 5                  |       |           |       |                        | 0.05                | 0.05  | V       |         |
|                                 |                       |                       | 10/0                  |                                | < 1                    | 10                 |       |           |       |                        | 0.05                | 0.05  |         |         |
|                                 |                       |                       | 15/0                  |                                | < 1                    | 15                 |       |           |       |                        | 0.05                | 0.05  |         |         |
| V <sub>IH</sub>                 | Input high voltage    |                       |                       | 0.5/4.5                        | < 1                    | 5                  | 3.5   |           | 3.5   |                        |                     | 3.5   | V       |         |
|                                 |                       |                       |                       | 1/9                            | < 1                    | 10                 | 7     |           | 7     |                        |                     | 7     |         |         |
|                                 |                       |                       |                       | 1.5/13.5                       | < 1                    | 15                 | 11    |           | 11    |                        |                     | 11    |         |         |
| V <sub>IL</sub>                 | Input low voltage     |                       |                       | 4.5/0.5                        | < 1                    | 5                  |       | 1.5       |       |                        | 1.5                 | 1.5   | V       |         |
|                                 |                       |                       |                       | 9/1                            | < 1                    | 10                 |       | 3         |       |                        | 3                   | 3     |         |         |
|                                 |                       |                       |                       | 13.5/1.5                       | < 1                    | 15                 |       | 4         |       |                        | 4                   | 4     |         |         |
| I <sub>OH</sub>                 | Output drive current  | G, H types            | 0/ 5                  | 2.5                            |                        | 5                  | -2    |           | -1.6  | -3.2                   |                     | -1.15 | mA      |         |
|                                 |                       |                       | 0/ 5                  | 4.6                            |                        | 5                  | -0.64 |           | -0.51 | -1                     |                     | -0.36 |         |         |
|                                 |                       |                       | 0/10                  | 9.5                            |                        | 10                 | -1.6  |           | -1.3  | -2.6                   |                     | -0.9  |         |         |
|                                 |                       |                       | 0/15                  | 13.5                           |                        | 15                 | -4.2  |           | -3.4  | -6.8                   |                     | -2.4  |         |         |
|                                 |                       | E, F types            | 0/ 5                  | 2.5                            |                        | 5                  | -1.53 |           | -1.36 | -3.2                   |                     | -1.1  |         |         |
|                                 |                       |                       | 0/ 5                  | 4.6                            |                        | 5                  | -0.52 |           | -0.44 | -1                     |                     | -0.36 |         |         |
|                                 |                       |                       | 0/10                  | 9.5                            |                        | 10                 | -1.3  |           | -1.1  | -2.6                   |                     | -0.9  |         |         |
|                                 |                       |                       | 0/15                  | 13.5                           |                        | 15                 | -3.6  |           | -3.0  | -6.8                   |                     | -2.4  |         |         |
| I <sub>OL</sub>                 | Output sink current   | G, H types            | 0/ 5                  | 0.4                            |                        | 5                  | 0.64  |           | 0.51  | 1                      |                     | 0.36  | mA      |         |
|                                 |                       |                       | 0/10                  | 0.5                            |                        | 10                 | 1.6   |           | 1.3   | 2.6                    |                     | 0.9   |         |         |
|                                 |                       |                       | 0/15                  | 1.5                            |                        | 15                 | 4.2   |           | 3.4   | 6.8                    |                     | 2.4   |         |         |
|                                 |                       | E, F types            | 0/ 5                  | 0.4                            |                        | 5                  | 0.52  |           | 0.44  | 1                      |                     | 0.36  |         |         |
|                                 |                       |                       | 0/10                  | 0.5                            |                        | 10                 | 1.3   |           | 1.1   | 2.6                    |                     | 0.9   |         |         |
|                                 |                       |                       | 0/15                  | 1.5                            |                        | 15                 | 3.6   |           | 3.0   | 6.8                    |                     | 2.4   |         |         |
| I <sub>IH</sub> I <sub>IL</sub> | Input leakage current | G, H types            | 0/18                  | Any input                      |                        | 18                 |       | $\pm$ 0.1 |       | $\pm$ 10 <sup>-5</sup> | $\pm$ 0.1           |       | $\pm$ 1 | $\mu$ A |
|                                 |                       | E, F types            | 0/15                  |                                |                        | 15                 |       | $\pm$ 0.3 |       | $\pm$ 10 <sup>-5</sup> | $\pm$ 0.3           |       | $\pm$ 1 |         |
| C <sub>I</sub>                  | Input capacitance     |                       |                       | Any input                      |                        |                    |       |           |       | 5                      | 7.5                 |       | pF      |         |

\* T<sub>LOW</sub> = -55°C for G, H devices; -40°C for E, F devices.

\* T<sub>HIGH</sub> = +125°C for G, H devices; +85°C for E, F devices.

The Noise Margin for both "1" and "0" level is:

- 1 V min. with V<sub>DD</sub> = 5 V
- 2 V min. with V<sub>DD</sub> = 10 V
- 2.5 V min. with V<sub>DD</sub> = 15 V



**DYNAMIC ELECTRICAL CHARACTERISTICS**

( $T_A = 25^\circ\text{C}$ ,  $C_L = 50\text{ pF}$ ,  $R_L = 200\text{ kohm}$ , typical temperature coefficient for all  $V_{DD} = 0.3\%/^\circ\text{C}$ , all input rise and fall times = 20 ns).

| PARAMETER                                     | TEST CONDITIONS | VALUES       |      |      | UNIT |      |
|---|-----------------|--------------|------|------|------|------|
|   |                 | $V_{DD}$ (V) | min. | typ. |      | max. |
| $t_{PHL}$<br>$t_{PLH}$ Propagation delay time |                 | 5            |      | 150  | 300  | ns   |
|   |                 | 10           |      | 75   | 150  |      |
|   |                 | 15           |      | 55   | 110  |      |
| $t_{TLH}$<br>$t_{THL}$ Transition time        |                 | 5            |      | 100  | 200  | ns   |
|   |                 | 10           |      | 50   | 100  |      |
|   |                 | 15           |      | 40   | 80   |      |

**LOGIC DIAGRAM**

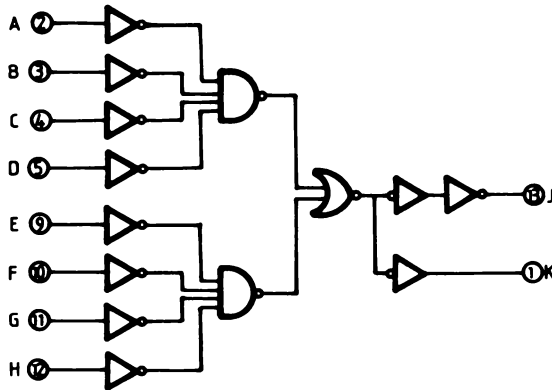

# CMOS AND GATES:

## 4081 QUAD 2 - INPUT AND GATE

## 4082 DUAL 4 - INPUT AND GATE

## 4073 TRIPLE 3 - INPUT AND GATE

### GENERAL DESCRIPTION

The MMC 4081, MMC 4082 and MMC 4073, AND gates provide the system designer with direct implementation of the AND function and supplement the existing family of COS/MOS gates. The MMC 4081, MMC 4082 and MMC 4073 types are supplied in 14 — lead dual — in — line ceramic or plastic packages.

### FEATURES

- Medium speed operation  $t_{PLH} = 85$  ns (TYP);  $t_{PHL} = 65$  ns (TYP) at 10 V
- Quiescent current specified to 20 V

### ABSOLUTE MAXIMUM RATINGS

|            |  |                               |                          |                |
|------------|--|-------------------------------|--------------------------|----------------|
| $V_{DD}^*$ | Supply voltage: G and H types<br>E and F types   | -0.5 to<br>-0.5 to<br>-0.5 to | 20<br>18<br>$V_{DD}+0.5$ | V<br>V<br>V    |
| $V_i$      | Input voltage  |                               |                          | V              |
| $I_i$      | DC input current (any one input)   |                               | $\pm 10$                 | mA             |
| $P_{tot}$  | Total power dissipation (per package)<br>Dissipation per output transistor<br>for $T_A =$ full package-temperature range |                               | 200                      | mW             |
| $T_A$      | Operating temperature : G and H types<br>E and F types   | -55 to<br>-40 to<br>-65 to    | 125<br>85<br>150         | °C<br>°C<br>°C |
| $T_{stg}$  | Storage temperature  |                               |                          | °C             |

\* All voltage values are referred to  $V_{SS}$  pin voltage

### RECOMMENDED OPERATING CONDITIONS

|            |   |                  |           |          |
|------------|---|------------------|-----------|----------|
| $V_{DD}^*$ | Supply voltage: G and H types<br>E and F types          | 3 to<br>3 to     | 18<br>15  | V<br>V   |
| $V_i$      | Input voltage   | 0 to             | $V_{DD}$  | V        |
| $T_A$      | Operating temperature : G and H types<br>E and F types. | -55 to<br>-40 to | 125<br>85 | °C<br>°C |

### CONNECTION DIAGRAM

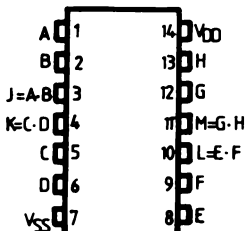
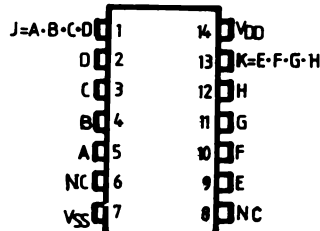
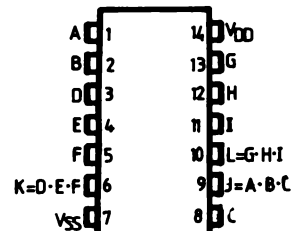
**MMC 4081**

**MMC 4082**

**MMC 4073**

**STATIC ELECTRICAL CHARACTERISTICS**

(over recommended operating conditions)

| PARAMETER                         |                       | TEST CONDITIONS       |                       |                          |                        | VALUES           |       |       |       |                   |                   | UNIT  |      |
|-----------------------------------|-----------------------|-----------------------|-----------------------|--------------------------|------------------------|------------------|-------|-------|-------|-------------------|-------------------|-------|------|
|                                   |                       | V <sub>I</sub><br>(V) | V <sub>O</sub><br>(V) | I <sub>O</sub>  <br>(μA) | V <sub>DD</sub><br>(V) | T <sub>LOW</sub> |       | 25°C  |       |                   | T <sub>HIGH</sub> |       |      |
|                                   |                       |                       |                       |                          |                        | min.             | max.  | min.  | typ   | max.              | min.              |       | max. |
| I <sub>L</sub>                    | Quiescent current     | G, H types            | 0/ 5                  |                          |                        | 5                |       | 0.25  |       | 0.01              | 0.25              |       | 7.5  |
|                                   |                       |                       | 0/10                  |                          |                        | 10               |       | 0.5   |       | 0.01              | 0.5               |       | 15   |
|                                   |                       |                       | 0/15                  |                          |                        | 15               |       | 1     |       | 0.01              | 1                 |       | 30   |
|                                   |                       |                       | 0/20                  |                          |                        | 20               |       | 5     |       | 0.02              | 5                 |       | 150  |
|                                   | E, F types            | 0/ 5                  |                       |                          | 5                      |                  | 1     |       | 0.01  | 1                 |                   | 7.5   |      |
|                                   |                       | 0/10                  |                       |                          | 10                     |                  | 2     |       | 0.01  | 2                 |                   | 15    |      |
|                                   |                       | 0/15                  |                       |                          | 15                     |                  | 4     |       | 0.01  | 4                 |                   | 30    |      |
| V <sub>OH</sub>                   | Output high voltage   | 0/ 5                  |                       | < 1                      | 5                      | 4.95             |       | 4.95  |       |                   | 4.95              |       |      |
|                                   |                       | 0/10                  |                       | < 1                      | 10                     | 9.95             |       | 9.95  |       |                   | 9.95              |       |      |
|                                   |                       | 0/15                  |                       | < 1                      | 15                     | 14.95            |       | 14.95 |       |                   | 14.95             |       |      |
| V <sub>OL</sub>                   | Output low voltage    | 5 /0                  |                       | < 1                      | 5                      |                  | 0.05  |       |       | 0.05              |                   | 0.05  |      |
|                                   |                       | 10/0                  |                       | < 1                      | 10                     |                  | 0.05  |       |       | 0.05              |                   | 0.05  |      |
|                                   |                       | 15/0                  |                       | < 1                      | 15                     |                  | 0.05  |       |       | 0.05              |                   | 0.05  |      |
| V <sub>IH</sub>                   | Input high voltage    |                       | 0.5/4.5               | < 1                      | 5                      | 3.5              |       | 3.5   |       |                   | 3.5               |       |      |
|                                   |                       |                       | 1/9                   | < 1                      | 10                     | 7                |       | 7     |       |                   | 7                 |       |      |
|                                   |                       |                       | 1.5/13.5              | < 1                      | 15                     | 11               |       | 11    |       |                   | 11                |       |      |
| V <sub>IL</sub>                   | Input low voltage     |                       | 4.5/0.5               | < 1                      | 5                      |                  | 1.5   |       |       | 1.5               |                   | 1.5   |      |
|                                   |                       |                       | 9/1                   | < 1                      | 10                     |                  | 3     |       |       | 3                 |                   | 3     |      |
|                                   |                       |                       | 13.5/1.5              | < 1                      | 15                     |                  | 4     |       |       | 4                 |                   | 4     |      |
| I <sub>OH</sub>                   | Output drive current  | G, H types            | 0/ 5                  | 2.5                      |                        | 5                | -2    |       | -1.6  | -3.2              |                   | -1.15 |      |
|                                   |                       |                       | 0/ 5                  | 4.6                      |                        | 5                | -0.64 |       | -0.51 | -1                |                   | -0.36 |      |
|                                   |                       |                       | 0/10                  | 9.5                      |                        | 10               | -1.6  |       | -1.3  | -2.6              |                   | -0.9  |      |
|                                   |                       |                       | 0/15                  | 13.5                     |                        | 15               | -4.2  |       | -3.4  | -6.8              |                   | -2.4  |      |
|                                   |                       | E, F types            | 0/ 5                  | 2.5                      |                        | 5                | -1.53 |       | -1.36 | -3.2              |                   | -1.1  |      |
|                                   |                       |                       | 0/ 5                  | 4.6                      |                        | 5                | -0.52 |       | -0.44 | -1                |                   | -0.36 |      |
|                                   |                       | 0/10                  | 9.5                   |                          | 10                     | -1.3             |       | -1.1  | -2.6  |                   | -0.9              |       |      |
|                                   |                       | 0/15                  | 13.5                  |                          | 15                     | -3.6             |       | -3.0  | -6.8  |                   | -2.4              |       |      |
| I <sub>OL</sub>                   | Output sink current   | G, H types            | 0/ 5                  | 0.4                      |                        | 5                | 0.64  |       | 0.51  | 1                 |                   | 0.36  |      |
|                                   |                       |                       | 0/10                  | 0.5                      |                        | 10               | 1.6   |       | 1.3   | 2.6               |                   | 0.9   |      |
|                                   |                       |                       | 0/15                  | 1.5                      |                        | 15               | 4.2   |       | 3.4   | 6.8               |                   | 2.4   |      |
|                                   |                       |                       | E, F types            | 0/ 5                     | 0.4                    |                  | 5     | 0.52  |       | 0.44              | 1                 |       | 0.36 |
|                                   |                       | 0/10                  |                       | 0.5                      |                        | 10               | 1.3   |       | 1.1   | 2.6               |                   | 0.9   |      |
|                                   |                       |                       |                       | 0/15                     | 1.5                    |                  | 15    | 3.6   |       | 3.0               | 6.8               |       | 2.4  |
| I <sub>IH</sub> / I <sub>IL</sub> | Input leakage current | G, H types            | 0/18                  | Any input                |                        | 18               |       | ±0.1  |       | ±10 <sup>-5</sup> | ±0.1              |       | ±1   |
|                                   |                       | E, F types            | 0/15                  |                          |                        | 15               |       | ±0.3  |       | ±10 <sup>-5</sup> | ±0.3              |       | ±1   |
| C <sub>I</sub>                    | Input capacitance     |                       | Any input             |                          |                        |                  |       |       | 5     | 7.5               |                   | pF    |      |

\* T<sub>LOW</sub> = -55°C for G, H devices; -40°C for E, F devices.

\* T<sub>HIGH</sub> = +125°C for G, H devices; +85°C for E, F devices.

The Noise Margin for both "1" and "0" level is:

1 V min. with V<sub>DD</sub> = 5 V

2 V min. with V<sub>DD</sub> = 10 V

2.5 V min. with V<sub>DD</sub> = 15 V

**DYNAMIC ELECTRICAL CHARACTERISTICS**

( $T_{amb} = 25^{\circ}C$ ,  $C_L = 50$  pF,  $R_L = 200k$ , typical temperature coefficient for all  $V_{DD}$  values is  $0.3\%/^{\circ}C$ , all input rise and fall times = 20 ns)

| PARAMETER                                       | TEST CONDITIONS | VALUES       |     |     | UNIT |
|---|-----------------|--------------|-----|-----|------|
|   |                 | $V_{DD}$ (V) | min | typ |      |
| $t_{PLH}$ : Propagation delay time<br>$t_{PHL}$ | 5               |              | 125 | 250 | ns   |
|   | 10              |              | 60  | 120 |      |
|   | 15              |              | 45  | 90  |      |
| $t_{THL}$ : Transition time<br>$t_{TLH}$        | 5               |              | 100 | 200 | ns   |
|   | 10              |              | 50  | 100 |      |
|   | 15              |              | 40  | 80  |      |

**SCHEMATIC AND LOGIC DIAGRAMS**

**MMC 4081**

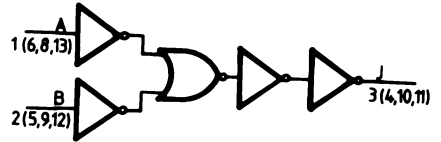
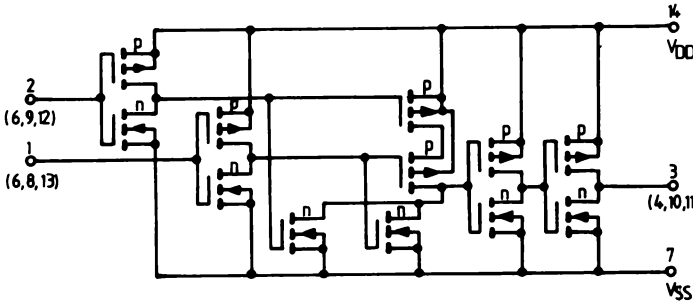

**MMC 4082**

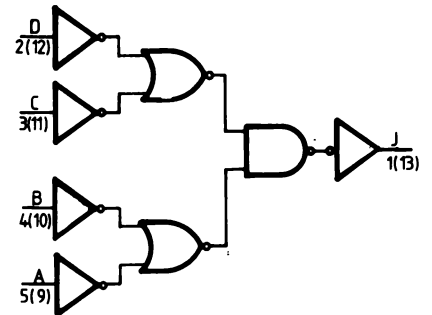
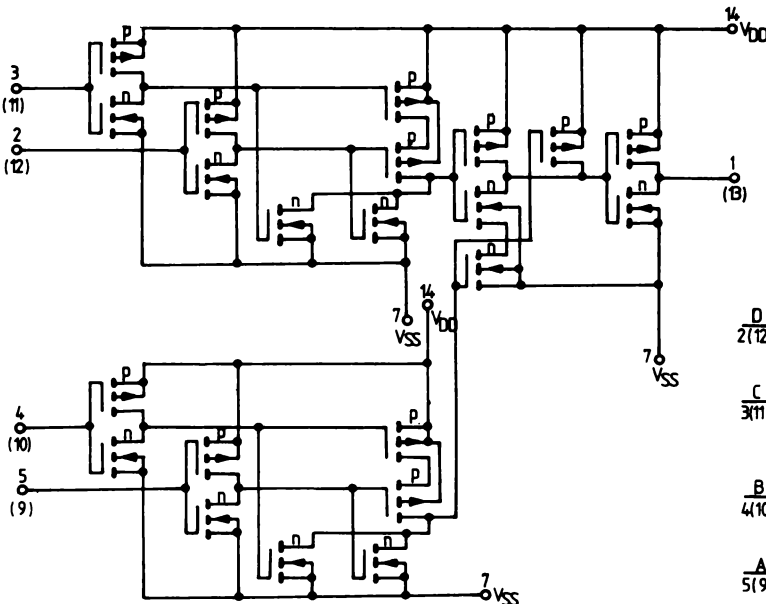

MMC 4073

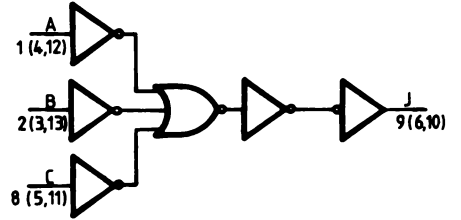
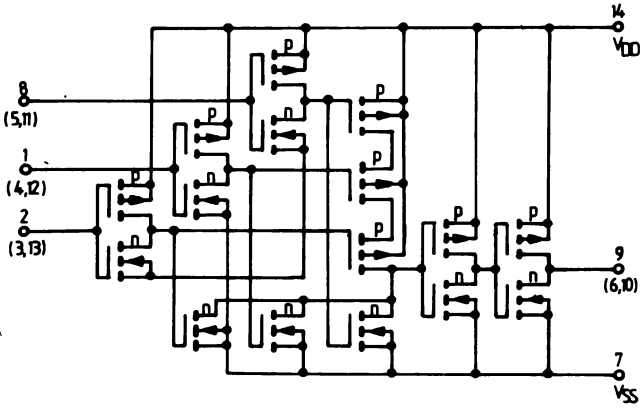

# QUAD 2-INPUT NAND SCHMITT TRIGGERS

## GENERAL DESCRIPTION

The MMC 4093 consists of four Schmitt-trigger circuits. Each circuit functions as a two-input NAND gate with Schmitt-trigger action on both inputs. The gate switches at different points for positive and negative going signals. The difference between the positive voltage ( $V_P$ ) and negative voltage ( $V_N$ ) is defined as hysteresis voltage ( $V_H$ ). The MMC 4093 types are supplied in 14-lead hermetic dual-in-line ceramic or plastic packages.

## FEATURES

- Schmitt-trigger action on each input with no external components
- Hysteresis voltage typically 0.9 V at  $V_{DD} = 5$  V and 2.3 V at  $V_{DD} = 10$  V
- No limit on input rise and fall times

## APPLICATIONS

- Wave and pulse shapers
- High-noise-environment systems
- Monostable multivibrators
- Astable multivibrators
- NAND logic

## ABSOLUTE MAXIMUM RATINGS

|            |  |                          |                              |
|------------|--|--------------------------|------------------------------|
| $V_{DD}^*$ | Supply voltage: G and H types<br>E and F types   | -0.5 to 20<br>-0.5 to 18 | V<br>V                       |
| $V_i$      | Input voltage  | -0.5 to $V_{DD}+0.5$     | V                            |
| $I_{i1}$   | DC input current (any one input)   | $\pm 10$                 | mA                           |
| $P_{tot}$  | Total power dissipation (per package)<br>Dissipation per output transistor<br>for $T_A =$ full package-temperature range | 200<br>100               | mW<br>mW                     |
| $T_A$      | Operating temperature : G and H types<br>E and F types   | -55 to 125<br>-40 to 85  | $^{\circ}$ C<br>$^{\circ}$ C |
| $T_{stg}$  | Storage temperature  | -65 to 150               | $^{\circ}$ C                 |

\* All voltage values are referred to  $V_{SS}$  pin voltage

## RECOMMENDED OPERATING CONDITIONS

|            |  |                         |                              |
|------------|--|-------------------------|------------------------------|
| $V_{DD}^*$ | Supply voltage: G and H types<br>E and F types         | 3 to 18<br>3 to 15      | V<br>V                       |
| $V_i$      | Input voltage  | 0 to $V_{DD}$           | V                            |
| $T_A$      | Operating temperature : G and H types<br>E and F types | -55 to 125<br>-40 to 85 | $^{\circ}$ C<br>$^{\circ}$ C |

## CONNECTION DIAGRAM

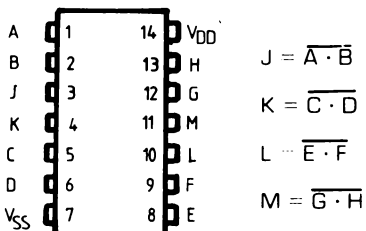

## FUNCTIONAL DIAGRAM

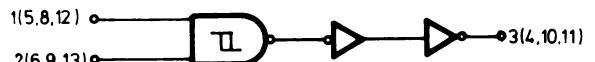

**STATIC ELECTRICAL CHARACTERISTICS**

(over recommended operating conditions)

| PARAMETER       |                                    |                 | TEST CONDITIONS       |                       |                          |                        | VALUES             |      |       |       |       |                     | UNIT |       |       |
|-----------------|------------------------------------|-----------------|-----------------------|-----------------------|--------------------------|------------------------|--------------------|------|-------|-------|-------|---------------------|------|-------|-------|
|                 |                                    |                 | V <sub>I</sub><br>(V) | V <sub>O</sub><br>(V) | I <sub>O</sub>  <br>(μA) | V <sub>DD</sub><br>(V) | T <sub>LOW</sub> * |      | 25°C  |       |       | T <sub>HIGH</sub> * |      |       |       |
|                 |                                    |                 |                       |                       |                          |                        | min.               | max. | min.  | typ   | max.  | min.                |      | max.  |       |
| I <sub>L</sub>  | Quiescent current                  | G, H types      | 0/ 5                  |                       |                          | 5                      |                    | 1    |       | 0.02  | 1     |                     | 30   |       |       |
|                 |                                    |                 | 0/10                  |                       |                          | 10                     |                    | 2    |       | 0.02  | 2     |                     | 60   |       |       |
|                 |                                    |                 | 0/15                  |                       |                          | 15                     |                    | 4    |       | 0.02  | 4     |                     | 120  |       |       |
|                 |                                    |                 | 0/20                  |                       |                          | 20                     |                    | 20   |       | 0.04  | 20    |                     | 600  |       |       |
|                 |                                    | E, F types      | 0/ 5                  |                       |                          | 5                      |                    | 4    |       | 0.02  | 4     |                     | 30   |       |       |
|                 |                                    |                 | 0/10                  |                       |                          | 10                     |                    | 8    |       | 0.02  | 8     |                     | 60   |       |       |
| V <sub>P</sub>  | Positive trigger threshold voltage | a               |                       |                       |                          | 5                      | 2.2                | 3.6  | 2.2   | 2.9   | 3.6   | 2.2                 | 3.6  |       |       |
|                 |                                    |                 |                       |                       |                          | 10                     | 4.6                | 7.1  | 4.6   | 5.9   | 7.1   | 4.6                 | 7.1  |       |       |
|                 |                                    |                 |                       |                       |                          | 15                     | 6.8                | 10.8 | 6.8   | 8.8   | 10.8  | 6.8                 | 10.8 |       |       |
|                 |                                    |                 | b                     |                       |                          | 5                      | 2.6                | 4    | 2.6   | 3.3   | 4     | 2.6                 | 4    |       |       |
|                 |                                    |                 |                       |                       |                          | 10                     | 5.6                | 8.2  | 5.6   | 7     | 8.2   | 5.6                 | 8.2  |       |       |
|                 |                                    |                 |                       |                       |                          | 15                     | 6.3                | 12.7 | 6.3   | 9.4   | 12.7  | 6.3                 | 12.7 |       |       |
|                 |                                    | a               |                       |                       | 5                        | 0.9                    | 2.8                | 0.9  | 1.9   | 2.8   | 0.9   | 2.8                 |      |       |       |
|                 |                                    |                 |                       |                       | 10                       | 2.5                    | 5.2                | 2.5  | 3.9   | 5.2   | 2.5   | 5.2                 |      |       |       |
|                 |                                    |                 |                       |                       | 15                       | 4                      | 7.4                | 4    | 5.8   | 7.4   | 4     | 7.4                 |      |       |       |
|                 |                                    |                 | b                     |                       |                          | 5                      | 1.4                | 3.2  | 1.4   | 2.3   | 3.2   | 1.4                 | 3.2  |       |       |
|                 |                                    |                 |                       |                       |                          | 10                     | 3.4                | 6.6  | 3.4   | 5.1   | 6.6   | 3.4                 | 6.6  |       |       |
|                 |                                    |                 |                       |                       |                          | 15                     | 4.8                | 9.6  | 4.8   | 7.3   | 9.6   | 4.8                 | 9.6  |       |       |
| V <sub>H</sub>  | Hysteresis voltage                 | a               |                       |                       |                          | 5                      | 0.3                | 1.6  | 0.3   | 0.9   | 1.6   | 0.3                 | 1.6  |       |       |
|                 |                                    |                 |                       |                       |                          | 10                     | 1.2                | 3.4  | 1.2   | 2.3   | 3.4   | 1.2                 | 3.4  |       |       |
|                 |                                    |                 |                       |                       |                          | 15                     | 1.6                | 5    | 1.6   | 3.5   | 5     | 1.6                 | 5    |       |       |
|                 |                                    |                 | b                     |                       |                          | 5                      | 0.3                | 1.6  | 0.3   | 0.9   | 1.6   | 0.3                 | 1.6  |       |       |
|                 |                                    |                 |                       |                       |                          | 10                     | 1.2                | 3.4  | 1.2   | 2.3   | 3.4   | 1.2                 | 3.4  |       |       |
|                 |                                    |                 |                       |                       |                          | 15                     | 1.6                | 5    | 1.6   | 3.5   | 5     | 1.6                 | 5    |       |       |
|                 |                                    | I <sub>OH</sub> | Output drive current  | G, H types            | 0/ 5                     | 2.5                    |                    | 5    | -2    |       | -1.6  | -3.2                |      | -1.15 |       |
|                 |                                    |                 |                       |                       | 0/ 5                     | 4.6                    |                    | 5    | -0.64 |       | -0.51 | -1                  |      | -0.36 |       |
|                 |                                    |                 |                       |                       | 0/10                     | 9.5                    |                    | 10   | -1.6  |       | -1.3  | -2.6                |      | -0.9  |       |
|                 |                                    |                 |                       |                       | 0/15                     | 13.5                   |                    | 15   | -4.2  |       | -3.4  | -6.8                |      | -2.4  |       |
|                 |                                    |                 |                       |                       | E, F types               | 0/ 5                   | 2.5                |      | 5     | -1.53 |       | -1.36               | -3.2 |       | -1.1  |
|                 |                                    |                 |                       |                       |                          | 0/ 5                   | 4.6                |      | 5     | -0.52 |       | -0.44               | -1   |       | -0.36 |
| 0/10            | 9.5                                |                 |                       |                       |                          | 10                     | -1.3               |      | -1.1  | -2.6  |       | -0.9                |      |       |       |
| 0/15            | 13.5                               |                 |                       |                       |                          | 15                     | -3.6               |      | -3.0  | -6.8  |       | -2.4                |      |       |       |
| V <sub>OH</sub> | Output high voltage                |                 |                       | 0/ 5                  |                          |                        |                    |      | 5     | 4.95  |       | 4.95                |      |       | 4.95  |
|                 |                                    |                 |                       |                       |                          |                        |                    |      | 10    | 9.95  |       | 9.95                |      |       | 9.95  |
|                 |                                    |                 |                       |                       |                          |                        |                    | 15   | 14.95 |       | 14.95 |                     |      | 14.95 |       |
|                 |                                    |                 |                       |                       | 0/10                     |                        |                    |      |       |       |       |                     |      |       |       |
|                 |                                    |                 |                       |                       |                          |                        |                    |      |       |       |       |                     |      |       |       |
|                 |                                    |                 |                       |                       |                          |                        |                    |      |       |       |       |                     |      |       |       |
|                 |                                    | 0/15            |                       |                       |                          |                        |                    |      |       |       |       |                     |      |       |       |
|                 |                                    |                 |                       |                       |                          |                        |                    |      |       |       |       |                     |      |       |       |
|                 |                                    |                 |                       |                       |                          |                        |                    |      |       |       |       |                     |      |       |       |

a: input on terminals 1, 5, 8, 12 or 2, 6, 9, 13; other inputs to V<sub>DD</sub>.  
 b: input on terminals 1 and 2, 5 and 6, 8 and 9, or 12 and 13;  
 other inputs to V<sub>DD</sub>.

| PARAMETER                         |                       | TEST CONDITIONS           |                           |                          |                        | VALUES             |                      |      |                    |                      |                     | UNIT               |      |    |
|-----------------------------------|-----------------------|---------------------------|---------------------------|--------------------------|------------------------|--------------------|----------------------|------|--------------------|----------------------|---------------------|--------------------|------|----|
|                                   |                       | V <sub>I</sub><br>(V)     | V <sub>O</sub><br>(V)     | I <sub>O</sub>  <br>(μA) | V <sub>DD</sub><br>(V) | T <sub>LOW</sub> * |                      | 25°C |                    |                      | T <sub>HIGH</sub> * |                    |      |    |
|                                   |                       |                           |                           |                          |                        | min.               | max.                 | min. | typ.               | max.                 | min.                |                    | max. |    |
| V <sub>OL</sub>                   | Output low voltage    | 5 / 0<br>10 / 0<br>15 / 0 |                           | < 1<br>< 1<br>< 1        | 5<br>10<br>15          |                    | 0.05<br>0.05<br>0.05 |      |                    | 0.05<br>0.05<br>0.05 |                     |                    | V    |    |
| I <sub>OL</sub>                   | Output sink current   | G, H types                | 0 / 5<br>0 / 10<br>0 / 15 | 0.4<br>0.5<br>1.5        |                        | 5<br>10<br>15      | 0.64<br>1.6<br>4.2   |      | 0.51<br>1.3<br>3.4 | 1<br>2.6<br>6.8      |                     | 0.36<br>0.9<br>2.4 |      | mA |
|                                   |                       | E, F types                | 0 / 5<br>0 / 10<br>0 / 15 | 0.4<br>0.5<br>1.5        |                        | 5<br>10<br>15      | 0.52<br>1.3<br>3.6   |      | 0.44<br>1.1<br>3.0 | 1<br>2.6<br>6.8      |                     | 0.36<br>0.9<br>2.4 |      |    |
| I <sub>IH</sub> , I <sub>IL</sub> | Input leakage current | G, H types                | 0 / 18                    | Any input                |                        | 18                 |                      | ±0.1 |                    | ±10 <sup>-5</sup>    | ±0.1                |                    | ±1   | μA |
|                                   |                       | E, F types                | 0 / 15                    |                          |                        | 15                 |                      | ±0.3 |                    | ±10 <sup>-5</sup>    | ±0.3                |                    | ±1   |    |
| C <sub>I</sub>                    | Input capacitance     |                           | Any input                 |                          |                        |                    |                      |      | 5                  | 7.5                  |                     |                    | pF   |    |

- \* T<sub>LOW</sub> = -55°C for G, H devices; -40°C for E, F devices.
  - \* T<sub>HIGH</sub> = +125°C for G, H devices; +85°C for E, F devices.
- The Noise Margin for both "1" and "0" level is:
- 1 V min. with V<sub>DD</sub> = 5 V
  - 2 V min. with V<sub>DD</sub> = 10 V
  - 2.5 V min. with V<sub>DD</sub> = 15 V

**DYNAMIC ELECTRICAL CHARACTERISTICS**

(T<sub>A</sub> = 25°C; input t<sub>r</sub>, t<sub>f</sub> = 20 ns, C<sub>L</sub> = 50 pF, R<sub>L</sub> = 200 kohm)

| PARAMETER        |                        | TEST CONDITIONS | VALUES              |      |      | UNIT |      |
|------------------|------------------------|-----------------|---------------------|------|------|------|------|
|                  |                        |                 | V <sub>DD</sub> (V) | min. | typ. |      | max. |
| t <sub>PHL</sub> | Propagation delay time |                 | 5                   |      | 190  | 300  | ns   |
| t <sub>PLH</sub> |                        |                 | 10                  |      | 90   | 180  |      |
|                  |                        |                 | 15                  |      | 65   | 90   |      |
| t <sub>THL</sub> | Transition time        |                 | 5                   |      | 100  | 200  | ns   |
| t <sub>TLH</sub> |                        |                 | 10                  |      | 50   | 100  |      |
|                  |                        |                 | 15                  |      | 40   | 80   |      |

Fig. 1' Hysteresis definition, characteristic and test setup  
(a) Definition of V<sub>p</sub>, V<sub>N</sub> and V<sub>H</sub>

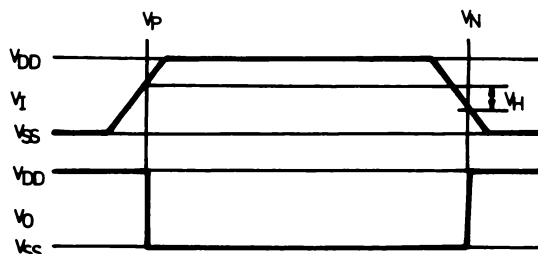



(b) Transfer characteristic of 1 of 4 gates

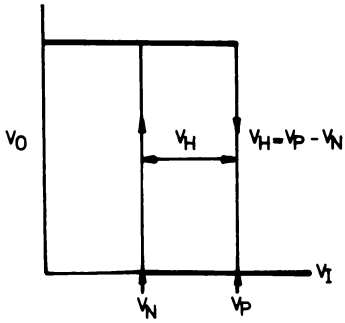

(c) Test setup

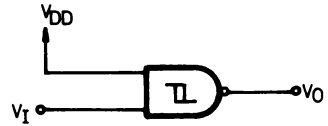
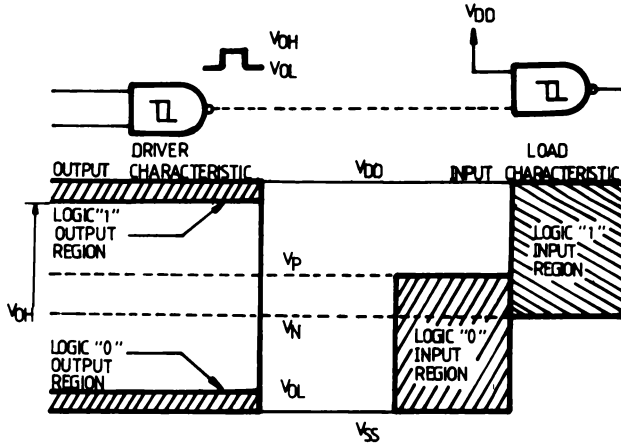

Fig. 2' Input and output characteristics



# GATED J-K MASTER-SLAVE FLIP-FLOPS

## GENERAL DESCRIPTION

The MMC 4095/4096 (intermediate or extended temperature range) are monolithic integrated circuits, available in 14-lead dual in-line plastic or ceramic package.

The MMC 4095 and MMC 4096 are J-K Master-Slave Flip-Flops featuring separate AND gating of multiple J and K inputs. The gated J-K inputs control transfer of information into the master section during clocked operation. Information on the J-K inputs is transferred to the Q and  $\bar{Q}$  outputs on the positive edge of the clock pulse. SET and RESET inputs (active high) are provided for asynchronous operation.

## FEATURES

- 16 MHz toggle rate (typ.) at  $V_{DD} - V_{SS} = 10\text{ V}$
- Gated inputs.

## ABSOLUTE MAXIMUM RATINGS

|            |  |         |                |    |
|------------|--|---------|----------------|----|
| $V_{DD}^*$ | Supply voltage: G and H types  | -0.5 to | 20             | V  |
|            | E and F types  | -0.5 to | 18             | V  |
| $V_i$      | Input voltage  | -0.5 to | $V_{DD} + 0.5$ | V  |
| $I_i$      | DC input current (any one input)   |         | $\pm 10$       | mA |
| $P_{tot}$  | Total power dissipation (per package)  |         | 200            | mW |
|            | Dissipation per output transistor for $T_A =$ full package-temperature range |         | 100            | mW |
| $T_A$      | Operating temperature :  |         |                |    |
|            | G and H types  | -55 to  | 125            | °C |
|            | E and F types  | -40 to  | 85             | °C |
| $T_{stg}$  | Storage temperature  | -65 to  | 150            | °C |

\* All voltage values are referred to  $V_{SS}$  pin voltage

## RECOMMENDED OPERATING CONDITIONS

|            |                               |        |          |    |
|------------|-------------------------------|--------|----------|----|
| $V_{DD}^*$ | Supply voltage: G and H types | 3 to   | 18       | V  |
|            | E and F types                 | 3 to   | 15       | V  |
| $V_i$      | Input voltage                 | 0 to   | $V_{DD}$ | V  |
| $T_A$      | Operating temperature :       |        |          |    |
|            | G and H types                 | -55 to | 125      | °C |
|            | E and F types                 | -40 to | 85       | °C |

## CONNECTION DIAGRAM

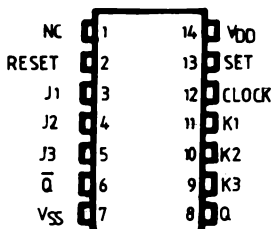
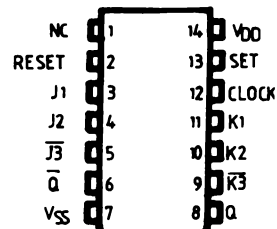
**MMC 4095**

**MMC 4096**

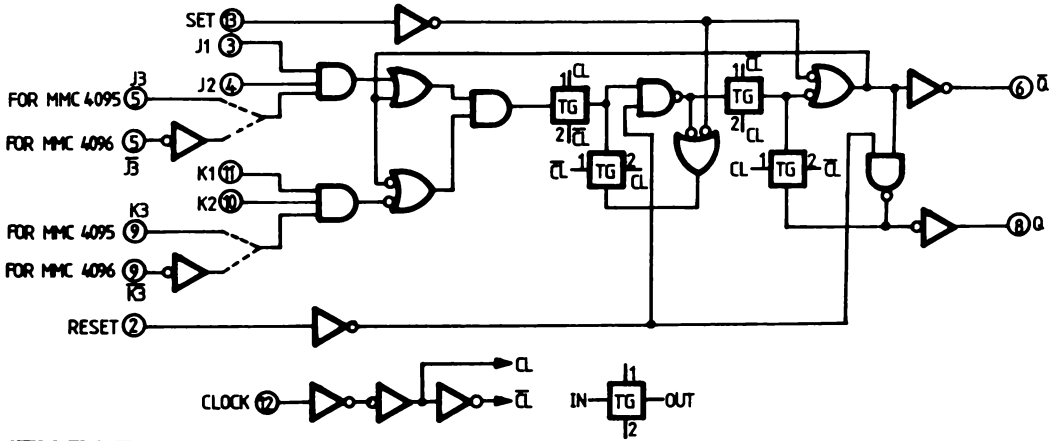
**LOGIC DIAGRAM**



**TRUTH TABLES**

**SYNCHRONOUS OPERATION**

(S = 0 R = 0)

| Inputs before positive clock transition |    | Outputs after positive clock transition |   |
|---|----|---|---|
| J*                                      | K* | Q                                       | Q |
| 0                                       | 0  | No change                               |   |
| 0                                       | 1  | 0                                       | 1 |
| 1                                       | 0  | 1                                       | 0 |
| 1                                       | 1  | Toggles                                 |   |

**ASYNCHRONOUS OPERATION**

(J and K — DON'T CARE)

| S | R | Q         | Q |
|---|---|-----------|---|
| 0 | 0 | No change |   |
| 0 | 1 | 0         | 1 |
| 1 | 0 | 1         | 0 |
| 1 | 1 | 0         | 0 |

\* For MMC 4095

For MMC 4096

$J = J1 \cdot J2 \cdot J3$

$J = J1 \cdot J2 \cdot \bar{J3}$

$K = K1 \cdot K2 \cdot K3$

$K = K1 \cdot K2 \cdot \bar{K3}$

$0 = V_{SS}, 1 = V_{DD}$

**STATIC ELECTRICAL CHARACTERISTICS**

(over recommended operating conditions)

| PARAMETER                           | TEST CONDITIONS | VALUES             |                    |                       |                     |                  |       |      |      |       |                   | UNIT |      |
|-------------------------------------|-----------------|--------------------|--------------------|-----------------------|---------------------|------------------|-------|------|------|-------|-------------------|------|------|
|                                     |                 | V <sub>I</sub> (V) | V <sub>O</sub> (V) | I <sub>O</sub>   (μA) | V <sub>DD</sub> (V) | T <sub>LOW</sub> |       | 25°C |      |       | T <sub>HIGH</sub> |      |      |
|                                     |                 |                    |                    |                       |                     | min.             | max.  | min. | typ. | max.  | min.              |      | max. |
| I <sub>L</sub> Quiescent current    | G, H types      | 0/ 5               |                    |                       | 5                   |                  | 1     |      | 0.02 | 1     |                   | 30   | μA   |
|                                     |                 | 0/10               |                    |                       | 10                  |                  | 2     |      | 0.02 | 2     |                   | 60   |      |
|                                     |                 | 0/15               |                    |                       | 15                  |                  | 4     |      | 0.02 | 4     |                   | 120  |      |
|                                     |                 | 0/20               |                    |                       | 20                  |                  | 20    |      | 0.04 | 20    |                   | 600  |      |
|                                     | E, F types      | 0/ 5               |                    |                       | 5                   |                  | 4     |      | 0.02 | 4     |                   | 30   |      |
|                                     |                 | 0/10               |                    |                       | 10                  |                  | 8     |      | 0.02 | 8     |                   | 60   |      |
|                                     |                 | 0/15               |                    |                       | 15                  |                  | 16    |      | 0.02 | 16    |                   | 120  |      |
| V <sub>OH</sub> Output high voltage | 0/ 5            |                    | < 1                | 5                     | 4.95                |                  | 4.95  |      |      | 4.95  |                   | V    |      |
|                                     | 0/10            |                    | < 1                | 10                    | 9.95                |                  | 9.95  |      |      | 9.95  |                   |      |      |
|                                     | 0/15            |                    | < 1                | 15                    | 14.95               |                  | 14.95 |      |      | 14.95 |                   |      |      |
| V <sub>OL</sub> Output low voltage  | 5 /0            |                    | < 1                | 5                     |                     | 0.05             |       |      | 0.05 |       | 0.05              | V    |      |
|                                     | 10/0            |                    | < 1                | 10                    |                     | 0.05             |       |      | 0.05 |       | 0.05              |      |      |
|                                     | 15/0            |                    | < 1                | 10                    |                     | 0.05             |       |      | 0.05 |       | 0.05              |      |      |
|                                     |                 |                    | < 1                | 15                    |                     | 0.05             |       |      | 0.05 |       | 0.05              |      |      |

| PARAMETER        |                       | TEST CONDITIONS |                              |                           |                 | $T_{LOW}^*$        |                                | VALUES         |                                |                            | $T_{HIGH}^*$   |                                | UNIT    |         |
|------------------|-----------------------|-----------------|------------------------------|---------------------------|-----------------|--------------------|--------------------------------|----------------|--------------------------------|----------------------------|----------------|--------------------------------|---------|---------|
|                  |                       | $V_I$<br>(V)    | $V_O$<br>(V)                 | $ I_{O1} $<br>( $\mu A$ ) | $V_{DD}$<br>(V) |                    |                                | 25°C           |                                |                            |                |                                |         |         |
|                  |                       |                 |                              |                           |                 | min.               | max.                           | min.           | typ.                           | max.                       | min.           | max.                           |         |         |
| $V_{IH}$         | Input high voltage    |                 | 0.5/4.5<br>1/9<br>1.5/13.5   | < 1<br>< 1<br>< 1         | 5<br>10<br>15   | 3.5<br>7<br>11     |                                | 3.5<br>7<br>11 |                                |                            | 3.5<br>7<br>11 |                                | V       |         |
| $V_{IL}$         | Input low voltage     |                 | 4.5/0.5<br>9/1<br>13.5/1.5   | < 1<br>< 1<br>< 1         | 5<br>10<br>15   |                    | 1.5<br>3<br>4                  |                |                                | 1.5<br>3<br>4              |                | 1.5<br>3<br>4                  |         | V       |
| $I_{OH}$         | Output drive current  | G, H types      | 0/ 5<br>0/ 5<br>0/10<br>0/15 | 2.5<br>4.6<br>9.5<br>13.5 |                 | 5<br>5<br>10<br>15 | -2<br>-0.64<br>-1.6<br>-4.2    |                | -1.6<br>-0.51<br>-1.3<br>-3.4  | -3.2<br>-1<br>-2.6<br>-6.8 |                | -1.15<br>-0.36<br>-0.9<br>-2.4 |         | mA      |
|                  |                       | E, F types      | 0/ 5<br>0/ 5<br>0/10<br>0/15 | 2.5<br>4.6<br>9.5<br>13.5 |                 | 5<br>5<br>10<br>15 | -1.53<br>-0.52<br>-1.3<br>-3.6 |                | -1.36<br>-0.44<br>-1.1<br>-3.0 | -3.2<br>-1<br>-2.6<br>-6.8 |                | -1.1<br>-0.36<br>-0.9<br>-2.4  |         |         |
| $I_{OL}$         | Output sink current   | G, H types      | 0/ 5<br>0/10<br>0/15         | 0.4<br>0.5<br>1.5         |                 | 5<br>10<br>15      | 0.64<br>1.6<br>4.2             |                | 0.51<br>1.3<br>3.4             | 1<br>2.6<br>6.8            |                | 0.36<br>0.9<br>2.4             |         | mA      |
|                  |                       | E, F types      | 0/ 5<br>0/10<br>0/15         | 0.4<br>0.5<br>1.5         |                 | 5<br>10<br>15      | 0.52<br>1.3<br>3.6             |                | 0.44<br>1.1<br>3.0             | 1<br>2.6<br>6.8            |                | 0.36<br>0.9<br>2.4             |         |         |
| $I_{IH}, I_{IL}$ | Input leakage current | G, H types      | 0/18                         | Any input                 |                 | 18                 |                                | $\pm 0.1$      |                                | $\pm 10^{-5}$              | $\pm 0.1$      |                                | $\pm 1$ | $\mu A$ |
|                  |                       | E, F types      | 0/15                         |                           |                 | 15                 |                                | $\pm 0.3$      |                                | $\pm 10^{-5}$              | $\pm 0.3$      |                                | $\pm 1$ |         |
| $C_i$            | Input capacitance     |                 | Any input                    |                           |                 |                    |                                |                |                                | 5                          | 7.5            |                                |         | pF      |

\*  $T_{LOW} = -55^\circ C$  for G, H devices;  $-40^\circ C$  for E, F devices.

\*  $T_{HIGH} = +125^\circ C$  for G, H devices;  $+85^\circ C$  for E, F devices.

The Noise Margin for both "1" and "0" level is:

- 1 V min. with  $V_{DD} = 5 V$
- 2 V min. with  $V_{DD} = 10 V$
- 2.5 V min. with  $V_{DD} = 15 V$

**DYNAMIC ELECTRICAL CHARACTERISTICS**

( $T_A = 25^\circ C$ ,  $C_L = 50 pF$ ,  $R_L = 200 kohm$ , typical temperature coefficient for all  $V_{DD} = 0.3\%/^\circ C$  all input rise and fall times = 20 ns).

| PARAMETER |                                       | TEST CONDITIONS |  | VALUES |      |      | UNIT |
|-----------|---------------------------------------|-----------------|--|--------|------|------|------|
|           |                                       | $V_{DD}$ (V)    |  | min.   | typ. | max. |      |
| $t_{PLH}$ | Propagation delay time                | 5               |  |        | 250  | 500  | ns   |
|           |                                       | 10              |  |        | 100  | 200  |      |
|           |                                       | 15              |  |        | 75   | 150  |      |
| $t_{PHL}$ | Propagation delay time (Set or reset) | 5               |  |        | 150  | 300  | ns   |
|           |                                       | 10              |  |        | 75   | 150  |      |
|           |                                       | 15              |  |        | 50   | 100  |      |

| PARAMETER                       | TEST CONDITIONS               | VALUES              |      |      | UNIT |      |
|---------------------------------|-------------------------------|---------------------|------|------|------|------|
|                                 |                               | V <sub>DD</sub> (V) | min. | typ. |      | max. |
| t <sub>THL</sub>                | Transition time               | 5                   |      | 100  | 200  | ns   |
| t <sub>TLH</sub>                |                               | 10                  |      | 50   | 100  |      |
|                                 |                               | 15                  |      | 40   | 80   |      |
| f <sub>CL</sub>                 | Maximum clock input frequency | 5                   | 3.5  | 7    |      | MHz  |
|                                 |                               | 10                  | 8    | 16   |      |      |
|                                 |                               | 15                  | 12   | 24   |      |      |
| t <sub>W</sub>                  | Clock pulse width             | 5                   | 140  | 70   |      | ns   |
|                                 |                               | 10                  | 60   | 30   |      |      |
|                                 |                               | 15                  | 40   | 20   |      |      |
| t <sub>w</sub> , t <sub>f</sub> | Clock input rise or fall time | 5                   |      |      | 15   | μs   |
|                                 |                               | 10                  |      |      | 5    |      |
|                                 |                               | 15                  |      |      | 5    |      |
| t <sub>W</sub>                  | Set or reset pulse width      | 5                   | 200  | 100  |      | ns   |
|                                 |                               | 10                  | 100  | 50   |      |      |
|                                 |                               | 15                  | 50   | 25   |      |      |
| t <sub>setup</sub>              | Data setup time               | 5                   | 400  | 200  |      | ns   |
|                                 |                               | 10                  | 160  | 80   |      |      |
|                                 |                               | 15                  | 100  | 50   |      |      |

**TYPICAL APPLICATIONS**

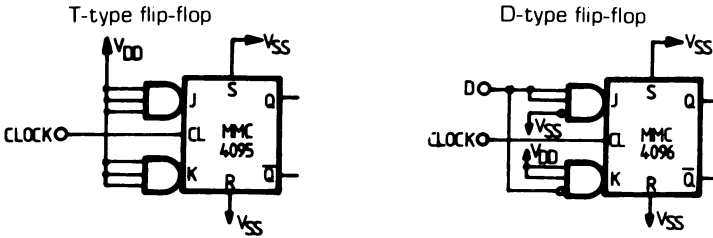

Synchronous binary divide-by-ten counter

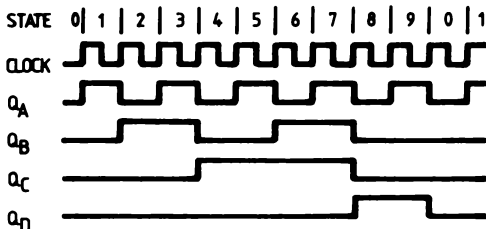
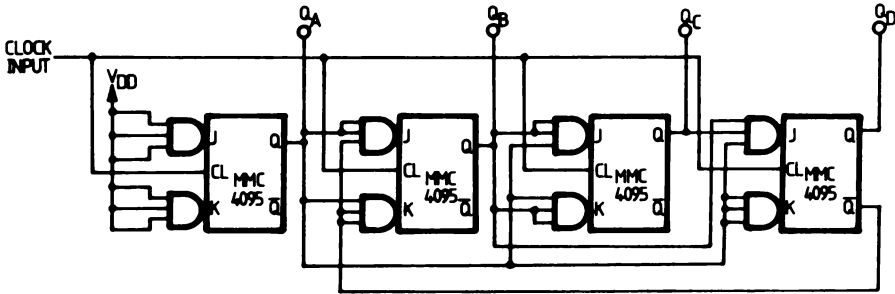

| STATE | Q <sub>A</sub> | Q <sub>B</sub> | Q <sub>C</sub> | Q <sub>D</sub> |
|-------|----------------|----------------|----------------|----------------|
| 0     | 0              | 0              | 0              | 0              |
| 1     | 1              | 0              | 0              | 0              |
| 2     | 0              | 1              | 0              | 0              |
| 3     | 1              | 1              | 0              | 0              |
| 4     | 0              | 0              | 1              | 0              |
| 5     | 1              | 0              | 1              | 0              |
| 6     | 0              | 1              | 1              | 0              |
| 7     | 1              | 1              | 1              | 0              |
| 8     | 0              | 0              | 0              | 1              |
| 9     | 1              | 0              | 0              | 1              |

In all MMC 4095 units the Set and Reset are connected to V<sub>SS</sub>

**WAVEFORMS**

Propagation delay, transition and setup-time

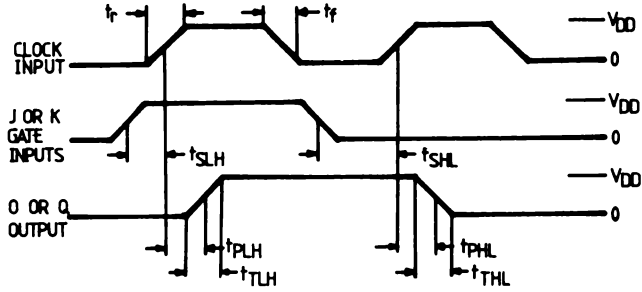

Clock pulse rise and fall time

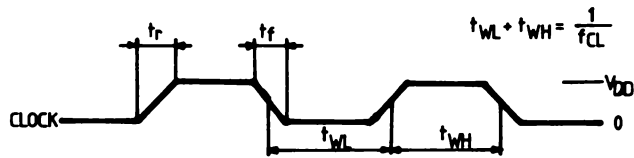

# DUAL MONOSTABLE MULTIVIBRATOR

## GENERAL DESCRIPTION

The MMC 4098 is a monolithic integrated circuit, available in 16-lead dual in-line plastic or ceramic package. The MMC 4098 dual monostable multivibrator provides stable retriggerable/resettable one-shot operation for any fixed-voltage timing application. An external resistor ( $R_X$ ) and an external capacitor ( $C_X$ ) control the timing for the circuit. Adjustment of  $R_X$  and  $C_X$  provides a wide range of output pulse widths from the Q and  $\bar{Q}$  terminals. The time delay from trigger input to output transition (trigger propagation delay) and the time delay from reset input to output transition (reset propagation delay) are independent of  $R_X$  and  $C_X$ .

Leading-edge-triggering (+TR) and trailing-edge-triggering (-TR) inputs are provided for triggering from either edge of an input pulse. An unused +TR input should be tied to  $V_{SS}$ . An unused -TR input should be tied to  $V_{DD}$ . A RESET (on low level) is provided for immediate termination of the output pulse or to prevent output pulses when power is turned on. An unused RESET input should be tied to  $V_{DD}$ . However, if an entire section of the MMC 4098 is not used, its RESET should be tied to  $V_{SS}$ . See Table I. In normal operation the circuit triggers (extends the output pulse one period) on the application of each new trigger pulse. For operation in the non-triggera-

ble mode, Q is connected to -TR when leading-edge triggering(+TR) is used or Q is connected to +TR when trailing-edge triggering (-TR) is used. The time period (T) for this multivibrator can be approximated

$$\text{by: } T_X = \frac{1}{2} R_X C_X \text{ for } C_X \geq 0.01 \mu\text{F. Values of T}$$

vary from unit to unit and as a function of voltage, temperature, and  $R_X C_X$ . The minimum value of external resistance,  $R_X$ , is 5 k $\Omega$ . The maximum value of external capacitance,  $C_X$ , is 100  $\mu\text{F}$ . The output pulse width has variations of  $\pm 2.5\%$  typically over the temperature range of  $-55^\circ\text{C}$  to  $125^\circ\text{C}$  for  $C_X = 1000 \text{ pF}$  and  $R_X = 100 \text{ k}\Omega$ .

For power supply variations of  $\pm 5\%$ , the output pulse width has variations of  $\pm 0.5\%$  typically, for  $V_{DD} = 10 \text{ V}$  and  $15 \text{ V}$  and  $\pm 1\%$  typically, for  $V_{DD} = 5 \text{ V}$  at  $C_X = 1000 \text{ pF}$  and  $R_X = 5 \text{ k}\Omega$ .

## FEATURES

- Retriggerable/resettable capability
- Trigger and reset propagation delays independent of  $R_X C_X$
- Triggering from leading or trailing edge
- Q and  $\bar{Q}$  buffered outputs available
- Separate resets
- Wide range of output-pulse widths

## ABSOLUTE MAXIMUM RATINGS

|            |  |                    |                |                                      |
|------------|--|--------------------|----------------|--------------------------------------|
| $V_{DD}^*$ | Supply voltage: G and H types<br>E and F types   | -0.5 to<br>-0.5 to | 20<br>18       | V<br>V                               |
| $V_i$      | Input voltage  | -0.5 to            | $V_{DD} + 0.5$ | V                                    |
| $I_i$      | DC input current (any one input)   |                    | $\pm 10$       | mA                                   |
| $P_{tot}$  | Total power dissipation (per package)<br>Dissipation per output transistor<br>for $T_A =$ full package-temperature range |                    | 200            | mW                                   |
| $T_A$      | Operating<br>temperature : G and H types<br>E and F types  | -55 to<br>-40 to   | 125<br>85      | $^\circ\text{C}$<br>$^\circ\text{C}$ |
| $T_{stg}$  | Storage temperature  | -65 to             | 150            | $^\circ\text{C}$                     |

\* All voltage values are referred to  $V_{SS}$  pin voltage

## RECOMMENDED OPERATING CONDITIONS

|            |   |                  |           |                                      |
|------------|---|------------------|-----------|--------------------------------------|
| $V_{DD}^*$ | Supply voltage: G and H types<br>E and F types            | 3 to<br>3 to     | 18<br>15  | V<br>V                               |
| $V_i$      | Input voltage   | 0 to             | $V_{DD}$  | V                                    |
| $T_A$      | Operating<br>temperature : G and H types<br>E and F types | -55 to<br>-40 to | 125<br>85 | $^\circ\text{C}$<br>$^\circ\text{C}$ |

## CONNECTION DIAGRAM

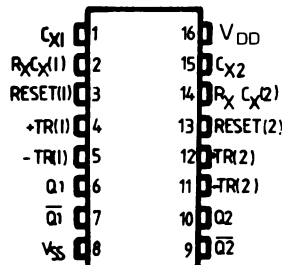

LOGIC DIAGRAM

FUNCTIONAL DIAGRAM

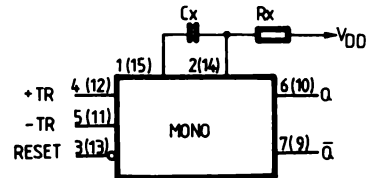
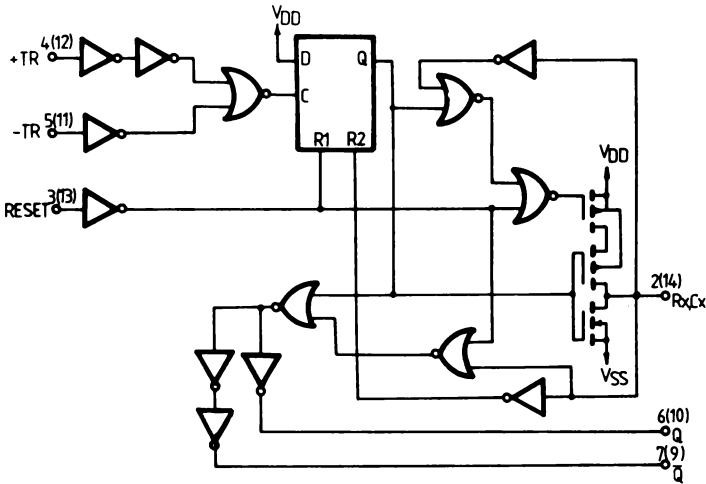
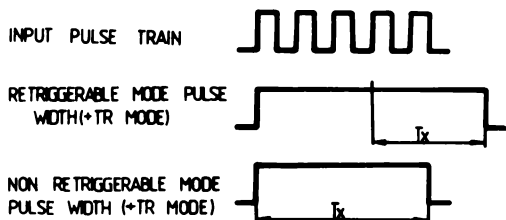

TABLE I

— Functional terminal connections

| FUNCTION                                | TERMINAL CONNECTIONS |          |          |          | INPUT PULSE TO |          | OTHER CONNECTIONS |          |
|---|----------------------|----------|----------|----------|----------------|----------|-------------------|----------|
|   | TO VDD               |          | TO VSS   |          |                |          |                   |          |
|   | Mono (1)             | Mono (2) | Mono (1) | Mono (2) | Mono (1)       | Mono (2) | Mono (1)          | Mono (2) |
| Leading-Edge Trigger/Retriggerable      | 3,5                  | 11,13    |          |          | 4              | 12       |                   |          |
| Leading-Edge Trigger/Non-retriggerable  | 3                    | 13       |          |          | 4              | 12       | 5,7               | 11,9     |
| Trailing-Edge Trigger/Retriggerable     | 3                    | 13       | 4        | 12       | 5              | 11       |                   |          |
| Trailing-Edge Trigger/Non-retriggerable | 3                    | 13       |          |          | 5              | 11       | 4,6               | 12,10    |
| Unused Section                          | 5                    | 11       | 3,4      | 12,13    |                |          |                   |          |

- NOTES: 1) A Retriggerable one-shot multivibrator has an output pulse width which is extended one full time period ( $T_x$ ) after application of the last trigger pulse.  
 2) A Non-retriggerable one-shot multivibrator has a time period  $T_x$  referenced from the application of the first trigger pulse.





**STATIC ELECTRICAL CHARACTERISTICS**

(over recommended operating conditions)

| PARAMETER                         |                       | TEST CONDITIONS       |                       |                          |                        | VALUES             |       |       |                   |      |                     | UNIT  |      |
|-----------------------------------|-----------------------|-----------------------|-----------------------|--------------------------|------------------------|--------------------|-------|-------|-------------------|------|---------------------|-------|------|
|                                   |                       | V <sub>I</sub><br>(V) | V <sub>O</sub><br>(V) | I <sub>O</sub>  <br>(μA) | V <sub>DD</sub><br>(V) | T <sub>LOW</sub> * |       | 25°C  |                   |      | T <sub>HIGH</sub> * |       |      |
|                                   |                       |                       |                       |                          |                        | min.               | max.  | min.  | typ               | max. | min.                |       | max. |
| I <sub>L</sub>                    | Quiescent current     | G, H types            | 0/ 5                  |                          |                        | 5                  |       | 1     |                   | 0.02 | 1                   |       | 30   |
|                                   |                       |                       | 0/10                  |                          |                        | 10                 |       | 2     |                   | 0.02 | 2                   |       | 60   |
|                                   |                       |                       | 0/15                  |                          |                        | 15                 |       | 4     |                   | 0.02 | 4                   |       | 120  |
|                                   |                       |                       | 0/20                  |                          |                        | 20                 |       | 20    |                   | 0.04 | 20                  |       | 600  |
|                                   | E, F types            | 0/ 5                  |                       |                          | 5                      |                    | 4     |       | 0.02              | 4    |                     | 30    |      |
|                                   |                       | 0/10                  |                       |                          | 10                     |                    | 8     |       | 0.02              | 8    |                     | 60    |      |
|                                   |                       | 0/15                  |                       |                          | 15                     |                    | 16    |       | 0.02              | 16   |                     | 120   |      |
| V <sub>OH</sub>                   | Output high voltage   | 0/ 5                  |                       | < 1                      | 5                      | 4.95               |       | 4.95  |                   |      | 4.95                |       |      |
|                                   |                       | 0/10                  |                       | < 1                      | 10                     | 9.95               |       | 9.95  |                   |      | 9.95                |       |      |
|                                   |                       | 0/15                  |                       | < 1                      | 15                     | 14.95              |       | 14.95 |                   |      | 14.95               |       |      |
| V <sub>OL</sub>                   | Output low voltage    | 5 /0                  |                       | < 1                      | 5                      |                    | 0.05  |       |                   | 0.05 |                     | 0.05  |      |
|                                   |                       | 10/0                  |                       | < 1                      | 10                     |                    | 0.05  |       |                   | 0.05 |                     | 0.05  |      |
|                                   |                       | 15/0                  |                       | < 1                      | 15                     |                    | 0.05  |       |                   | 0.05 |                     | 0.05  |      |
| V <sub>IH</sub>                   | Input high voltage    |                       | 0.5/4.5               | < 1                      | 5                      | 3.5                |       | 3.5   |                   |      | 3.5                 |       |      |
|                                   |                       |                       | 1/9                   | < 1                      | 10                     | 7                  |       | 7     |                   |      | 7                   |       |      |
|                                   |                       |                       | 1.5/13.5              | < 1                      | 15                     | 11                 |       | 11    |                   |      | 11                  |       |      |
| V <sub>IL</sub>                   | Input low voltage     |                       | 4.5/0.5               | < 1                      | 5                      |                    | 1.5   |       |                   | 1.5  |                     | 1.5   |      |
|                                   |                       |                       | 9/1                   | < 1                      | 10                     |                    | 3     |       |                   | 3    |                     | 3     |      |
|                                   |                       |                       | 13.5/1.5              | < 1                      | 15                     |                    | 4     |       |                   | 4    |                     | 4     |      |
| I <sub>OH</sub>                   | Output drive current  | G, H types            | 0/ 5                  | 2.5                      |                        | 5                  | -2    |       | -1.6              | -3.2 |                     | -1.15 |      |
|                                   |                       |                       | 0/ 5                  | 4.6                      |                        | 5                  | -0.64 |       | -0.51             | -1   |                     | -0.36 |      |
|                                   |                       |                       | 0/10                  | 9.5                      |                        | 10                 | -1.6  |       | -1.3              | -2.6 |                     | -0.9  |      |
|                                   |                       |                       | 0/15                  | 13.5                     |                        | 15                 | -4.2  |       | -3.4              | -6.8 |                     | -2.4  |      |
|                                   |                       | E, F types            | 0/ 5                  | 2.5                      |                        | 5                  | -1.53 |       | -1.36             | -3.2 |                     | -1.1  |      |
|                                   |                       |                       | 0/ 5                  | 4.6                      |                        | 5                  | -0.52 |       | -0.44             | -1   |                     | -0.36 |      |
|                                   |                       | 0/10                  | 9.5                   |                          | 10                     | -1.3               |       | -1.1  | -2.6              |      | -0.9                |       |      |
|                                   |                       | 0/15                  | 13.5                  |                          | 15                     | -3.6               |       | -3.0  | -6.8              |      | -2.4                |       |      |
| I <sub>OL</sub>                   | Output sink current   | G, H types            | 0/ 5                  | 0.4                      |                        | 5                  | 0.64  |       | 0.51              | 1    |                     | 0.36  |      |
|                                   |                       |                       | 0/10                  | 0.5                      |                        | 10                 | 1.6   |       | 1.3               | 2.6  |                     | 0.9   |      |
|                                   |                       |                       | 0/15                  | 1.5                      |                        | 15                 | 4.2   |       | 3.4               | 6.8  |                     | 2.4   |      |
|                                   |                       | E, F types            | 0/ 5                  | 0.4                      |                        | 5                  | 0.52  |       | 0.44              | 1    |                     | 0.36  |      |
|                                   |                       |                       | 0/10                  | 0.5                      |                        | 10                 | 1.3   |       | 1.1               | 2.6  |                     | 0.9   |      |
|                                   |                       |                       | 0/15                  | 1.5                      |                        | 15                 | 3.6   |       | 3.0               | 6.8  |                     | 2.4   |      |
| I <sub>IH</sub> , I <sub>IL</sub> | Input leakage current | G, H types            | 0/18                  | Any input                | 18                     |                    | ±0.1  |       | ±10 <sup>-5</sup> | ±0.1 |                     | ±1    |      |
|                                   |                       | E, F types            | 0/15                  |                          | 15                     |                    | ±0.3  |       | ±10 <sup>-5</sup> | ±0.3 |                     | ±1    |      |
| C <sub>I</sub>                    | Input capacitance     |                       | Any input             |                          |                        |                    |       |       | 5                 | 7.5  |                     | pF    |      |

\* T<sub>LOW</sub> = -55°C for G, H devices; -40°C for E, F devices.

\* T<sub>HIGH</sub> = +125°C for G, H devices; +85°C for E, F devices.

The Noise Margin for both "1" and "0" level is:

- 1 V min. with V<sub>DD</sub> = 5 V
- 2 V min. with V<sub>DD</sub> = 10 V
- 2.5 V min. with V<sub>DD</sub> = 15 V

**DYNAMIC ELECTRICAL CHARACTERISTICS**

( $T_{amb} = 25^{\circ}C$ ,  $C_L = 50$  pF,  $R_L = 200$  k $\Omega$ , typical temperature coefficient for all  $V_{DD}$  values is 0.3%/ $^{\circ}C$ , all input rise and fall time = 20 ns)

| PARAMETER                                     | TEST CONDITIONS     |              |              | VALUES |      |      | UNIT    |
|---|---------------------|--------------|--------------|--------|------|------|---------|
|   | $R_X$ (k $\Omega$ ) | $C_X$ (pF)   | $V_{DD}$ (V) | Min.   | Typ. | Max. |         |
| $t_{PLH}$ , Trigger propagation delay         | 5 to                | $\geq 15$    | 5            |        | 250  | 500  | ns      |
| $t_{PHL}$ , time (+TR, -TR to Q, $\bar{Q}$ )  | 10 000              |              | 10           |        | 125  | 250  |         |
|   |                     |              | 15           |        | 100  | 200  |         |
| $t_{WH}$ , Trigger pulse width                | 5 to                | $\geq 15$    | 5            | 140    | 70   |      | ns      |
| $t_{WL}$                                      | 10 000              |              | 10           | 60     | 30   |      |         |
|   |                     |              | 15           | 40     | 20   |      |         |
| $t_{TLH}$ , Transition time                   | 5 to                | $\geq 15$    | 5            |        | 100  | 200  |         |
|   | 10 000              |              | 10           |        | 50   | 100  |         |
|   |                     |              | 15           |        | 40   | 80   |         |
| $t_{THL}$ , Transition time                   | 5 to                | 15 to        | 5            |        | 100  | 200  | ns      |
|   | 10 000              | 10 000       | 10           |        | 50   | 100  |         |
|   |                     |              | 15           |        | 40   | 80   |         |
|   | 5 to                | 0.01 $\mu F$ | 5            |        | 150  | 300  |         |
|   | 10 000              | to           | 10           |        | 75   | 150  |         |
|   |                     | 0.1 $\mu F$  | 15           |        | 65   | 130  |         |
|   | 5 to                | 0.1 $\mu F$  | 5            |        | 250  | 500  |         |
|   | 10 000              | to           | 10           |        | 150  | 300  |         |
|   |                     | 1 $\mu F$    | 15           |        | 80   | 160  |         |
| $t_{PLH}$ , Propagation delay time            | 5 to                |              | 5            |        | 225  | 450  | ns      |
| $t_{PHL}$ , (Reset)                           | 10 000              | $\geq 15$    | 10           |        | 125  | 250  |         |
|   |                     |              | 15           |        | 75   | 150  |         |
| $t_{WR}$ , Pulse width (Reset)                |                     |              | 5            | 200    | 100  |      | ns      |
|   |                     | 15           | 10           | 80     | 40   |      |         |
|   |                     |              | 15           | 60     | 30   |      |         |
|   |                     |              | 5            | 1 200  | 600  |      |         |
|   | 100                 | 1 000        | 10           | 600    | 300  |      |         |
|   |                     |              | 15           | 500    | 250  |      |         |
|   |                     | 0.1 $\mu F$  | 5            | 50     | 25   |      | $\mu s$ |
|   |                     |              | 10           | 30     | 15   |      |         |
|   |                     |              | 15           | 20     | 10   |      |         |
| $t_r, t_f$ , (TR) Rise or fall time (Trigger) |                     |              | 5 to 15      |        |      | 100  | $\mu s$ |

| PARAMETER  | TEST CONDITIONS     |                     |                     | VALUES |      |      | UNIT |
|--|---------------------|---------------------|---------------------|--------|------|------|------|
|  | R <sub>x</sub> (kΩ) | C <sub>x</sub> (pF) | V <sub>DD</sub> (V) | Min.   | Typ. | Max. |      |
| Pulse width match between circuits in same package | 10                  | 10 000              | 5                   |        | 5    | 10   | %    |
|  |                     |                     | 10                  |        | 7.5  | 15   |      |
|  |                     |                     | 15                  |        | 7.5  | 15   |      |

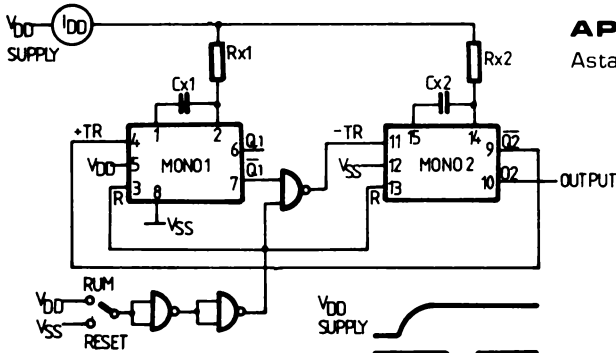

**APPLICATIONS**

Astable multivibrator with restart after reset capability

TO ENSURE RESTART APPLY RESET NEGATIVE PULSE AFTER V<sub>DD</sub> SUPPLY VOLTAGE HAS REACHED ITS V<sub>DD</sub> LEVEL

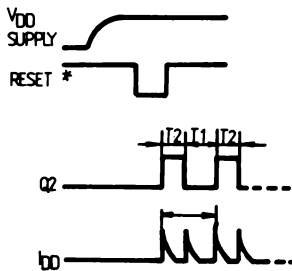

| R <sub>x</sub> | I <sub>DD</sub> (Avg) | T <sub>x</sub> (T1+T2) | V <sub>DD</sub> |
|----------------|-----------------------|------------------------|-----------------|
| 10 kΩ          | 1 mA / 0.05 mA        | 3.8 s / 0.5 s          | 5 V             |
|                | 2.5 mA / 0.5 mA       | 3.2 s / 0.5 s          | 10 V            |
| ↓<br>10 MΩ     | 5 mA / 1 mA           | 3 s / 0.5 s            | 15 V            |

NOTE:  
ALL VALUES ARE TYPICAL  
C<sub>x</sub> RANGE: 0,0001 μF TO 0,1 μF

Pulse delay

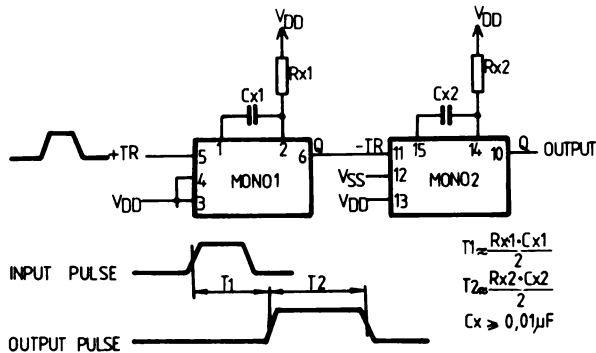

# HEX NON-INVERTING TRI-STATE BUFFER

## GENERAL DESCRIPTION

The MMC 4503 is a hex non-inverting TRI-STATE buffer with high output current sink and source capability. TRI-STATE outputs make it useful in bus oriented applications. Two separate disable inputs are provided. Buffers 1 to 4 are controlled by the disable **A** input. Buffers 5 and 6 are controlled by the disable **B** input. A high level on either disable input will cause those gates on its control line to go into a high impedance state.

## FEATURES

- Wide supply voltage range 3.0  $V_{DC}$  to 18  $V_{DC}$
- TRI-STATE outputs
- Symmetrical turn on/turn off delays
- Symmetrical output rise and fall times
- 1 TTL-load output drive capability
- 2 output-disable controls
- 100% tested for quiescent current

## ABSOLUTE MAXIMUM RATINGS

|            |  |  |                          |   |
|------------|--|--|--------------------------|---|
| $V_{DD}^*$ | Supply voltage: G and H types<br>E and F types   | -0.5 to 20<br>-0.5 to 18<br>-0.5 to $V_{DD}+0.5$ | 20<br>18<br>$V_{DD}+0.5$ | V<br>V<br>V                               |
| $V_i$      | Input voltage  |  |                          |   |
| $I_i$      | DC input current (any one input)   |  | $\pm 10$                 | mA  |
| $P_{tot}$  | Total power dissipation (per package)<br>Dissipation per output transistor<br>for $T_A$ = full package-temperature range |  | 200                      | mW  |
| $T_A$      | Operating temperature : G and H types<br>E and F types   | -55 to -40 to -65 to                             | 125<br>85<br>150         | $^{\circ}C$<br>$^{\circ}C$<br>$^{\circ}C$ |
| $T_{stg}$  | Storage temperature  |  |                          |   |

\* All voltage values are referred to  $V_{SS}$  pin voltage

## RECOMMENDED OPERATING CONDITIONS

|            |  |                |                      |                            |
|------------|--|----------------|----------------------|----------------------------|
| $V_{DD}^*$ | Supply voltage: G and H types<br>E and F types         | 3 to 3 to 0 to | 18<br>15<br>$V_{DD}$ | V<br>V<br>V                |
| $V_i$      | Input voltage  |                |                      |                            |
| $T_A$      | Operating temperature : G and H types<br>E and F types | -55 to -40 to  | 125<br>85            | $^{\circ}C$<br>$^{\circ}C$ |

## CONNECTION DIAGRAM

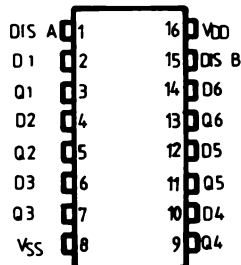

**STATIC ELECTRICAL CHARACTERISTICS**

(over recommended operating conditions)

| PARAMETER                       |                       |            | TEST CONDITIONS              |                            |                                |                        | VALUES                       |                      |                               |                               |                   |                              | UNIT                   |         |
|---------------------------------|-----------------------|------------|------------------------------|----------------------------|--------------------------------|------------------------|------------------------------|----------------------|-------------------------------|-------------------------------|-------------------|------------------------------|------------------------|---------|
|                                 |                       |            | V <sub>I</sub><br>(V)        | V <sub>O</sub><br>(V)      | I <sub>O</sub>  <br>( $\mu$ A) | V <sub>DD</sub><br>(V) | T <sub>Low</sub>             |                      | 25°C                          |                               |                   | T <sub>High</sub>            |                        |         |
|                                 |                       |            |                              |                            |                                |                        | min.                         | max.                 | min.                          | typ                           | max.              | min.                         |                        | max.    |
| I <sub>L</sub>                  | Quiescent current     | G, H types | 0/ 5<br>0/10<br>0/15<br>0/20 |                            |                                | 5<br>10<br>15<br>20    |                              | 1<br>2<br>4<br>20    |                               | 0.02<br>0.02<br>0.02<br>0.04  | 1<br>2<br>4<br>20 |                              | 30<br>60<br>120<br>600 | $\mu$ A |
|                                 |                       | E, F types | 0/ 5<br>0/10<br>0/15         |                            |                                | 5<br>10<br>15          |                              | 4<br>8<br>16         |                               | 0.02<br>0.02<br>0.02          | 4<br>8<br>16      |                              | 30<br>60<br>120        |         |
| V <sub>OH</sub>                 | Output high-voltage   |            | 0/ 5<br>0/10<br>0/15         |                            | < 1<br>< 1<br>< 1              | 5<br>10<br>15          | 4.95<br>9.95<br>14.95        |                      | 4.95<br>9.95<br>14.95         |                               |                   | 4.95<br>9.95<br>14.95        |                        | V       |
| V <sub>OL</sub>                 | Output low voltage    |            | 5 /0<br>10/0<br>15/0         |                            | < 1<br>< 1<br>< 1              | 5<br>10<br>15          |                              | 0.05<br>0.05<br>0.05 |                               |                               |                   | 0.05<br>0.05<br>0.05         |                        | V       |
| V <sub>IH</sub>                 | Input high voltage    |            |                              | 0.5/4.5<br>1/9<br>1.5/13.5 | < 1<br>< 1<br>< 1              | 5<br>10<br>15          | 3.5<br>7<br>11               |                      | 3.5<br>7<br>11                |                               |                   | 3.5<br>7<br>11               |                        | V       |
| V <sub>IL</sub>                 | Input low voltage     |            |                              | 4.5/0.5<br>9/1<br>13.5/1.5 | < 1<br>< 1<br>< 1              | 5<br>10<br>15          |                              | 1.5<br>3<br>4        |                               |                               |                   | 1.5<br>3<br>4                |                        | V       |
| I <sub>OH</sub>                 | Output drive current  | G, H types | 0/ 5<br>0/ 5<br>0/10<br>0/15 | 2.5<br>4.6<br>9.5<br>13.5  |                                | 5<br>5<br>10<br>15     | -5.8<br>-1.2<br>-3.1<br>-8.2 |                      | -4.8<br>-1.02<br>-2.6<br>-6.8 | -6.1<br>-1.9<br>-3.7<br>-14.1 |                   | -3<br>-0.7<br>-1.8<br>-4.8   |                        | mA      |
|                                 |                       | E, F types | 0/ 5<br>0/ 5<br>0/10<br>0/15 | 2.5<br>4.6<br>9.5<br>13.5  |                                | 5<br>5<br>10<br>15     | -4.8<br>-1<br>-2.5<br>-6.8   |                      | -4.1<br>-0.8<br>-2.2<br>-5.8  | -5.2<br>-1.6<br>-3.1<br>-11.9 |                   | -2.9<br>-0.6<br>-1.6<br>-4.2 |                        |         |
| I <sub>OL</sub>                 | Output sink current   | G, H types | 0/ 5<br>0/10<br>0/15         | 0.4<br>0.5<br>1.5          |                                | 5<br>10<br>15          | 2.6<br>6.5<br>19.2           |                      | 2.1<br>5.5<br>16.1            | 2.3<br>2.6<br>2.3             |                   | 1.3<br>3.8<br>11.2           |                        | mA      |
|                                 |                       | E, F types | 0/ 5<br>0/10<br>0/15         | 0.4<br>0.5<br>1.5          |                                | 5<br>10<br>15          | 2.1<br>5.4<br>1.6            |                      | 1.8<br>4.7<br>13.7            | 1.9<br>5.3<br>19.5            |                   | 1.2<br>3.3<br>9.7            |                        |         |
| I <sub>IH</sub> I <sub>IL</sub> | Input leakage current | G, H types | 0/18                         | Any input                  |                                | 18                     |                              | $\pm$ 0.1            |                               | $\pm$ 10 <sup>-5</sup>        | $\pm$ 0.1         |                              | $\pm$ 1                | $\mu$ A |
|                                 |                       | E, F types | 0/15                         |                            |                                | 15                     |                              | $\pm$ 0.3            |                               | $\pm$ 10 <sup>-5</sup>        | $\pm$ 0.3         |                              | $\pm$ 1                |         |
| I <sub>OH</sub>                 | 3—state output        | G, H types | 0/18                         | 0/18                       |                                | 18                     |                              | $\pm$ 0.4            |                               | $\pm$ 10 <sup>-4</sup>        | $\pm$ 0.4         |                              | $\pm$ 12               | $\mu$ A |
|                                 |                       | E, F types | 0/15                         | 0/15                       |                                | 15                     |                              | $\pm$ 1.0            |                               | $\pm$ 10 <sup>-4</sup>        | $\pm$ 1.0         |                              | $\pm$ 7.5              |         |

| PARAMETER                        | TEST CONDITIONS       |                       |                                |                        | VALUES             |      |      |     |      |                     | UNIT |      |
|----------------------------------|-----------------------|-----------------------|--------------------------------|------------------------|--------------------|------|------|-----|------|---------------------|------|------|
|                                  | V <sub>I</sub><br>(V) | V <sub>O</sub><br>(V) | I <sub>O</sub>  <br>( $\mu$ A) | V <sub>DD</sub><br>(V) | T <sub>LOW</sub> * |      | 25°C |     |      | T <sub>HIGH</sub> * |      |      |
|                                  |                       |                       |                                |                        | min.               | max. | min. | typ | max. | min.                |      | max. |
| C <sub>I</sub> Input capacitance |                       | Any input             |                                |                        |                    |      |      | 5   | 7.5  |                     |      | pF   |

- \* T<sub>LOW</sub> = -55°C for G, H devices; -40°C for E, F devices.
  - \* T<sub>HIGH</sub> = +125°C for G, H devices; +85°C for E, F devices.
- The Noise Margin for both "1" and "0" level is:
- 1 V min. with V<sub>DD</sub> = 5 V
  - 2 V min. with V<sub>DD</sub> = 10 V
  - 2.5 V min. with V<sub>DD</sub> = 15 V

**DYNAMIC ELECTRICAL CHARACTERISTICS**

(T<sub>A</sub> = 25°C, C<sub>L</sub> = 50 pF, R<sub>L</sub> = 200 k, typical temperature coefficient for all V<sub>DD</sub> = 0.3%/°C values, all input rise and fall time = 20 ns)

| PARAMETER                                       | TEST CONDITIONS | VALUES              |      |      | UNIT |
|---|-----------------|---------------------|------|------|------|
|   |                 | V <sub>DD</sub> (V) | min. | typ. |      |
| t <sub>PLH</sub> Propagation delay time         | 5               |                     | 75   | 150  | ns   |
| t <sub>PHL</sub> Low-to-High                    | 10              |                     | 35   | 70   |      |
|   | 15              |                     | 25   | 50   |      |
|   |                 |                     |      |      | ns   |
|   | 5               |                     | 55   | 110  |      |
|   | 10              |                     | 25   | 50   |      |
|   | 15              |                     | 17   | 35   |      |
| t <sub>PHZ</sub> 3—state propagation delay time | 5               |                     | 70   | 140  | ns   |
| t <sub>PZH</sub>                                | 10              |                     | 30   | 60   |      |
|   | 15              |                     | 25   | 50   |      |
| t <sub>PZL</sub> 3—state propagation delay time | 5               |                     | 90   | 180  | ns   |
| t <sub>PLZ</sub>                                | 10              |                     | 40   | 80   |      |
|   | 15              |                     | 35   | 70   |      |
| t <sub>TLH</sub> Transition time                | 5               |                     | 50   | 90   | ns   |
| t <sub>THL</sub> Low-to-High                    | 10              |                     | 30   | 45   |      |
|   | 15              |                     | 25   | 35   |      |
|   |                 |                     |      |      | ns   |
|   | 5               |                     | 35   | 70   |      |
|   | 10              |                     | 20   | 40   |      |
|   | 15              |                     | 13   | 25   |      |

**LOGIC DIAGRAM AND TRUTH TABLE**

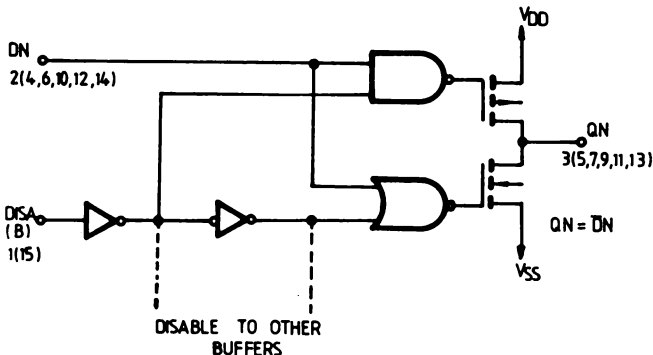

| DN | DISA(B) | QN     |
|----|---------|--------|
| 0  | 0       | 0      |
| 1  | 0       | 1      |
| X  | 1       | HIGH Z |

## DUAL 4-BIT LATCH

The MMC 4508 dual 4-bit latch contains two identical 4-bit latches with separate STROBE, RESET and OUTPUT DISABLE controls. With the STROBE line in high state, the data on the "D" inputs appear at the corresponding "Q" outputs provided the DISABLE line is in the low state. Changing the STROBE line to the low state locks the data into the latch. A high on the RESET line forces the outputs to a low level regardless of the state of the STROBE input. The outputs are forced to the high-impedance state for bus line application by a high level on the DISABLE input.

The MMC 4508 E/F/G/H types are supplied in the 24-lead dual-in-line ceramic or plastic packages.

## FEATURES

- Two independent 4-bit latches
- Individual master reset for each 4-bit latch
- 3-state outputs with high-impedance state for bus line applications
- Medium-speed operation:  $t_{PLH} = t_{PHL} = 70$  ns (typ.) at  $V_{DD} = 10$  V and  $C_L = 50$  pF

## APPLICATIONS

- Buffer storage
- Holding register
- Data storage and multiplexing

## ABSOLUTE MAXIMUM RATINGS

|            |  |                    |                |          |
|------------|--|--------------------|----------------|----------|
| $V_{DD}^*$ | Supply voltage: G and H types<br>E and F types   | -0.5 to<br>-0.5 to | 20<br>18       | V<br>V   |
| $V_i$      | Input voltage  | -0.5 to            | $V_{DD} + 0.5$ | V        |
| $I_i$      | DC input current (any one input)   |                    | $\pm 10$       | mA       |
| $P_{tot}$  | Total power dissipation (per package)<br>Dissipation per output transistor<br>for $T_A =$ full package-temperature range |                    | 200            | mW       |
| $T_A$      | Operating<br>temperature : G and H types<br>E and F types  | -55 to<br>-40 to   | 125<br>85      | °C<br>°C |
| $T_{stg}$  | Storage temperature  | -65 to             | 150            | °C       |

\* All voltage values are referred to  $V_{SS}$  pin voltage

## RECOMMENDED OPERATING CONDITIONS

|            |   |                  |           |          |
|------------|---|------------------|-----------|----------|
| $V_{DD}^*$ | Supply voltage: G and H types<br>E and F types            | 3 to<br>3 to     | 18<br>15  | V<br>V   |
| $V_i$      | Input voltage   | 0 to             | $V_{DD}$  | V        |
| $T_A$      | Operating<br>temperature : G and H types<br>E and F types | -55 to<br>-40 to | 125<br>85 | °C<br>°C |

## CONNECTION DIAGRAM

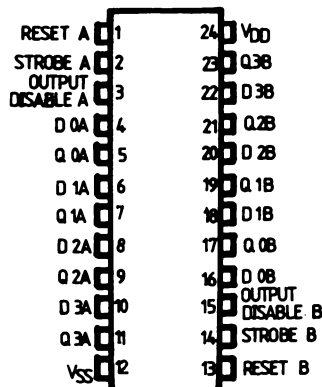

**STATIC ELECTRICAL CHARACTERISTICS**

(over recommended operating conditions)

| PARAMETER                         |                       | TEST CONDITIONS       |                            |                                |                        | VALUES                |                       |                       |                        |                      |                       | UNIT                  |      |
|-----------------------------------|-----------------------|-----------------------|----------------------------|--------------------------------|------------------------|-----------------------|-----------------------|-----------------------|------------------------|----------------------|-----------------------|-----------------------|------|
|                                   |                       | V <sub>I</sub><br>(V) | V <sub>O</sub><br>(V)      | I <sub>O</sub>  <br>( $\mu$ A) | V <sub>DD</sub><br>(V) | T <sub>LOW</sub> *    |                       | 25°C                  |                        |                      | T <sub>HIGH</sub> *   |                       |      |
|                                   |                       |                       |                            |                                |                        | min.                  | max.                  | min.                  | typ.                   | max.                 | min.                  |                       | max. |
| I <sub>L</sub>                    | Quiescent current     | G, H types            | 0/ 5                       |                                |                        | 5                     |                       | 5                     |                        | 0.04                 | 5                     |                       | 150  |
|                                   |                       |                       | 0/10                       |                                |                        | 10                    |                       | 10                    |                        | 0.04                 | 10                    |                       | 300  |
|                                   |                       |                       | 0/15                       |                                |                        | 15                    |                       | 20                    |                        | 0.04                 | 20                    |                       | 600  |
|                                   |                       |                       | 0/20                       |                                |                        | 20                    |                       | 100                   |                        | 0.08                 | 100                   |                       | 3000 |
|                                   | E, F types            | 0/ 5                  |                            |                                | 5                      |                       | 20                    |                       | 0.04                   | 20                   |                       | 150                   |      |
|                                   |                       | 0/10<br>0/15          |                            |                                | 10<br>15               |                       | 40<br>80              |                       | 0.04<br>0.04           | 40<br>80             |                       | 300<br>600            |      |
| V <sub>OH</sub>                   | Output high voltage   | 0/ 5<br>0/10<br>0/15  |                            | < 1<br>< 1<br>< 1              | 5<br>10<br>15          | 4.95<br>9.95<br>14.95 |                       | 4.95<br>9.95<br>14.95 |                        |                      | 4.95<br>9.95<br>14.95 |                       | V    |
| V <sub>OL</sub>                   | Output low voltage    | 5 /0<br>10/0<br>15/0  |                            | < 1<br>< 1<br>< 1              | 5<br>10<br>15          |                       | 0.05<br>0.05<br>0.05  |                       |                        | 0.05<br>0.05<br>0.05 |                       | 0.05<br>0.05<br>0.05  | V    |
| V <sub>IH</sub>                   | Input high voltage    |                       | 0.5/4.5<br>1/9<br>1.5/13.5 | < 1<br>< 1<br>< 1              | 5<br>10<br>15          | 3.5<br>7<br>11        |                       | 3.5<br>7<br>11        |                        |                      | 3.5<br>7<br>11        |                       | V    |
| V <sub>IL</sub>                   | Input low voltage     |                       | 4.5/0.5<br>9/1<br>13.5/1.5 | < 1<br>< 1<br>< 1              | 5<br>10<br>15          |                       | 1.5<br>3<br>4         |                       |                        | 1.5<br>3<br>4        |                       | 1.5<br>3<br>4         | V    |
| I <sub>OH</sub>                   | Output drive current  | G, H types            | 0/ 5                       | 2.5                            |                        | 5                     | -2                    |                       | -1.6                   | -3.2                 |                       | -1.15                 |      |
|                                   |                       |                       | 0/ 5                       | 4.6                            |                        | 5                     | -0.64                 |                       | -0.51                  | -1                   |                       | -0.36                 |      |
|                                   |                       |                       | 0/10                       | 9.5                            |                        | 10                    | -1.6                  |                       | -1.3                   | -2.6                 |                       | -0.9                  |      |
|                                   |                       |                       | 0/15                       | 13.5                           |                        | 15                    | -4.2                  |                       | -3.4                   | -6.8                 |                       | -2.4                  |      |
|                                   |                       | E, F types            | 0/ 5                       | 2.5                            |                        | 5                     | -1.53                 |                       | -1.36                  | -3.2                 |                       | -1.1                  |      |
|                                   |                       |                       | 0/ 5<br>0/10<br>0/15       | 4.6<br>9.5<br>13.5             |                        | 5<br>10<br>15         | -0.52<br>-1.3<br>-3.6 |                       | -0.44<br>-1.1<br>-3.0  | -1<br>-2.6<br>-6.8   |                       | -0.36<br>-0.9<br>-2.4 |      |
| I <sub>OL</sub>                   | Output sink current   | G, H types            | 0/ 5                       | 0.4                            |                        | 5                     | 0.64                  |                       | 0.51                   | 1                    |                       | 0.36                  |      |
|                                   |                       |                       | 0/10                       | 0.5                            |                        | 10                    | 1.6                   |                       | 1.3                    | 2.6                  |                       | 0.9                   |      |
|                                   |                       |                       | 0/15                       | 1.5                            |                        | 15                    | 4.2                   |                       | 3.4                    | 6.8                  |                       | 2.4                   |      |
|                                   |                       | E, F types            | 0/ 5                       | 0.4                            |                        | 5                     | 0.52                  |                       | 0.44                   | 1                    |                       | 0.36                  |      |
|                                   |                       |                       | 0/10                       | 0.5                            |                        | 10                    | 1.3                   |                       | 1.1                    | 2.6                  |                       | 0.9                   |      |
|                                   |                       |                       | 0/15                       | 1.5                            |                        | 15                    | 3.6                   |                       | 3.0                    | 6.8                  |                       | 2.4                   |      |
| I <sub>IH</sub> , I <sub>IL</sub> | Input leakage current | G, H types            | 0/18                       | Any input                      | 18                     |                       | $\pm$ 0.1             |                       | $\pm$ 10 <sup>-5</sup> | $\pm$ 0.1            |                       | $\pm$ 1               |      |
|                                   |                       | E, F types            | 0/15                       |                                | 15                     |                       | $\pm$ 0.3             |                       | $\pm$ 10 <sup>-5</sup> | $\pm$ 0.3            |                       | $\pm$ 1               |      |
| I <sub>OH</sub>                   | 3--state output       | G, H types            | 0/18                       | 0/18                           | 18                     |                       | $\pm$ 0.4             |                       | $\pm$ 10 <sup>-4</sup> | $\pm$ 0.4            |                       | $\pm$ 12              |      |
|                                   |                       | E, F types            | 0/15                       | 0/15                           | 15                     |                       | $\pm$ 1.0             |                       | $\pm$ 10 <sup>-4</sup> | $\pm$ 1.0            |                       | $\pm$ 7.5             |      |



| PARAMETER                         | TEST CONDITIONS       |                       |                        |                        | VALUES             |      |      |      |      |                     | UNIT |      |
|-----------------------------------|-----------------------|-----------------------|------------------------|------------------------|--------------------|------|------|------|------|---------------------|------|------|
|                                   | V <sub>I</sub><br>(V) | V <sub>O</sub><br>(V) | I <sub>O</sub><br>(μA) | V <sub>DD</sub><br>(V) | T <sub>LOW</sub> * |      | 25°C |      |      | T <sub>HIGH</sub> * |      |      |
|                                   |                       |                       |                        |                        | min.               | max. | min. | typ. | max. | min.                |      | max. |
| C <sub>I</sub> —Input capacitance |                       | Any input             |                        |                        |                    |      |      | 5    | 7.5  |                     |      | pF   |

\* T<sub>LOW</sub> = -55°C for G, H devices; -40°C for E, F devices.

\* T<sub>HIGH</sub> = +125°C for G, H devices; +85°C for E, F devices.

The Noise Margin for both "1" and "0" level is:

- 1 V min. with V<sub>DD</sub> = 5 V
- 2 V min. with V<sub>DD</sub> = 10 V
- 2.5 V min. with V<sub>DD</sub> = 15 V

**DYNAMIC ELECTRICAL CHARACTERISTICS**

(T<sub>A</sub> = 25°C, input t<sub>r</sub> t<sub>f</sub> = 20 ns, C<sub>L</sub> = 50 pF, R<sub>I</sub> = 200 kΩ, unless otherwise specified)

| PARAMETER   | TEST CONDITIONS     | VALUES              |      |      | UNIT |      |
|---|---------------------|---------------------|------|------|------|------|
|   |                     | V <sub>DD</sub> (V) | min. | typ. |      | max. |
| t <sub>THL</sub> Transition time<br>t <sub>TLH</sub>                            |                     | 5                   |      | 100  | 200  | ns   |
|   |                     | 10                  |      | 50   | 100  |      |
|   |                     | 15                  |      | 40   | 80   |      |
| t <sub>W(R)</sub> Reset pulse width   |                     | 5                   | 200  | 100  |      | ns   |
|   |                     | 10                  | 140  | 70   |      |      |
|   |                     | 15                  | 100  | 50   |      |      |
| t <sub>W(st)</sub> Strobe pulse width   |                     | 5                   | 140  | 70   |      | ns   |
|   |                     | 10                  | 80   | 40   |      |      |
|   |                     | 15                  | 70   | 35   |      |      |
| t <sub>setup</sub> Setup time   |                     | 5                   | 50   | 25   |      | ns   |
|   |                     | 10                  | 30   | 15   |      |      |
|   |                     | 15                  | 20   | 10   |      |      |
| t <sub>H</sub> Hold time  |                     | 5                   | 0    | 0    |      | ns   |
|   |                     | 10                  | 0    | 0    |      |      |
|   |                     | 15                  | 0    | 0    |      |      |
| t <sub>PHL</sub> Propagation delay times:<br>t <sub>PLH</sub>                   | Strobe to data out  | 5                   |      | 130  | 260  | ns   |
|   |                     | 10                  |      | 70   | 140  |      |
|   |                     | 15                  |      | 50   | 100  |      |
|   | Data in to data out | 5                   |      | 105  | 210  | ns   |
|   |                     | 10                  |      | 60   | 120  |      |
|   |                     | 15                  |      | 45   | 90   |      |
|   | Reset to data out   | 5                   |      | 90   | 180  | ns   |
|   |                     | 10                  |      | 50   | 100  |      |
|   |                     | 15                  |      | 40   | 80   |      |
| t <sub>PHZ</sub> 3-state propagation delay times: output high to high impedance |                     | 5                   |      | 90   | 180  | ns   |
|   |                     | 10                  |      | 50   | 100  |      |
|   |                     | 15                  |      | 35   | 70   |      |
| t <sub>PZH</sub> High impedance to output high                                  |                     | 5                   |      | 90   | 180  | ns   |
|   |                     | 10                  |      | 50   | 100  |      |
|   |                     | 15                  |      | 35   | 70   |      |
| t <sub>PLZ</sub> Output low to high impedance                                   |                     | 5                   |      | 90   | 180  | ns   |
|   |                     | 10                  |      | 50   | 100  |      |
|   |                     | 15                  |      | 35   | 70   |      |

| PARAMETER                                     | TEST CONDITIONS | VALUES              |      |      | UNIT |      |
|---|-----------------|---------------------|------|------|------|------|
|   |                 | V <sub>DD</sub> (V) | min. | typ. |      | max. |
| t <sub>pZL</sub> High impedance to output low |                 | 5                   |      | 90   | 180  | ns   |
|   |                 | 10                  |      | 50   | 100  |      |
|   |                 | 15                  |      | 35   | 70   |      |

**LOGIC DIAGRAM (A Section)**

1 of 4 identical latches with common output disable, reset and strobe

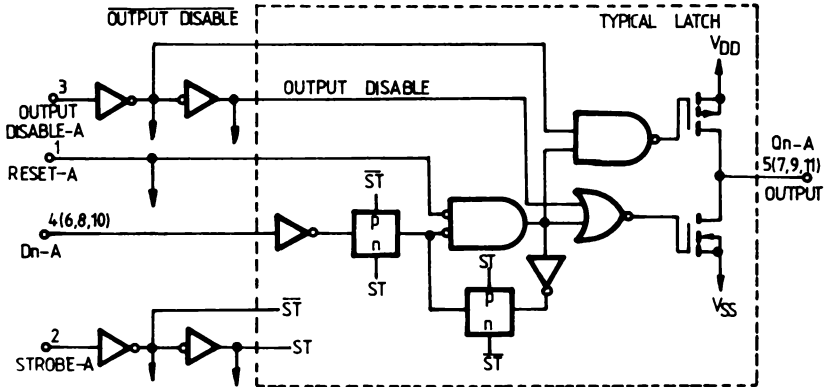

**TRUTH TABLE**

| RESET | DISAB | STROBE | D INPUT | Q INPUT |
|-------|-------|--------|---------|---------|
| 0     | 0     | 1      | 1       | 1       |
| 0     | 0     | 1      | 0       | 0       |
| 0     | 0     | 0      | X       | Latched |
| 1     | 0     | X      | X       | 0       |
| X     | 1     | X      | X       | Z       |

1 = High level  
0 = Low level

X = Don't care  
Z = High impedance

**TEST WAVEFORM**

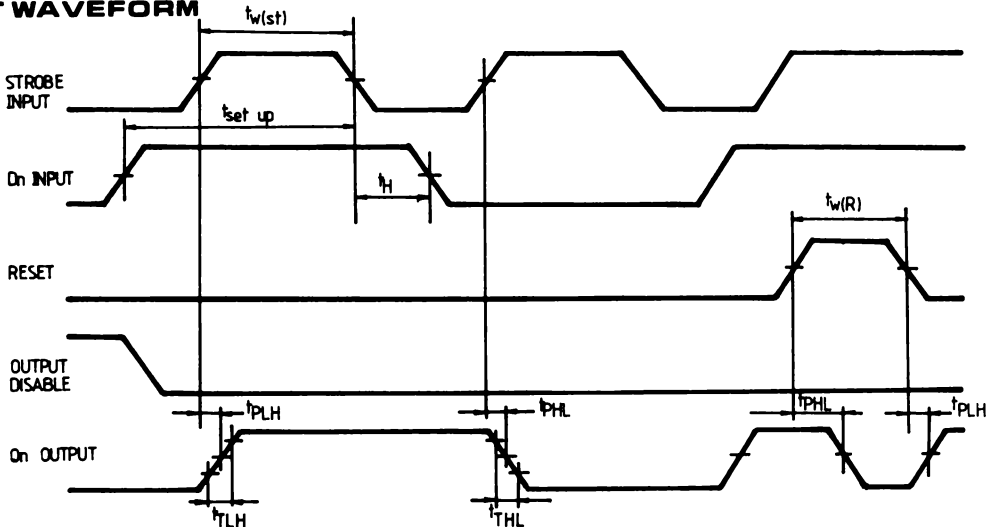

TYPICAL APPLICATIONS

Bus register

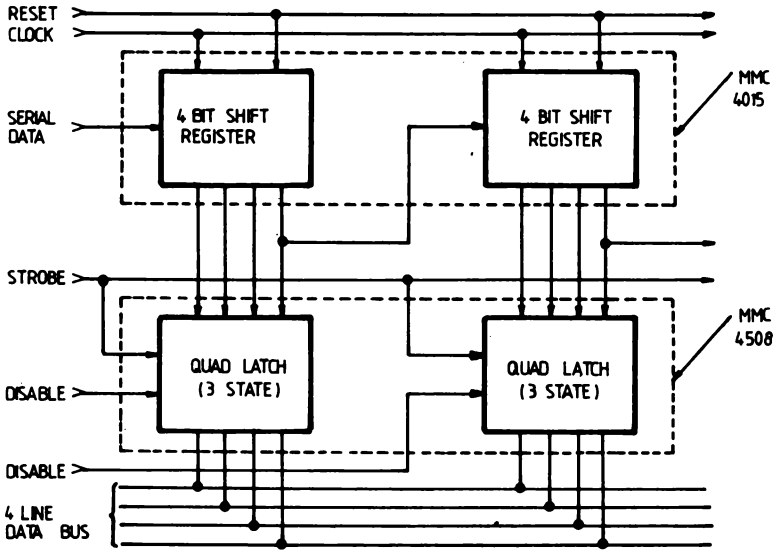

Dual multiplexed bus register with function select

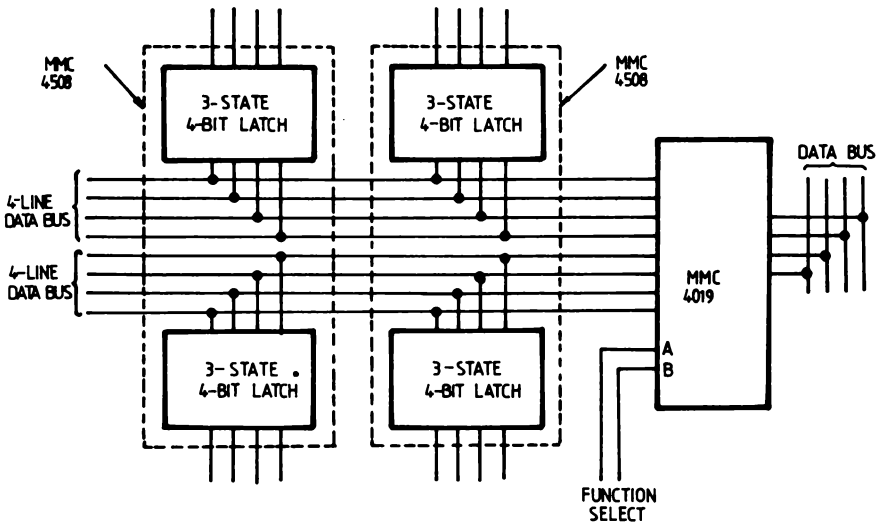

# PRESETTABLE UP/DOWN COUNTERS:

## MMC 4510 PRESETTABLE BCD UP/DOWN COUNTERS

## MMC 4516 PRESETTABLE BINARY UP/DOWN COUNTER

### GENERAL DESCRIPTION

The MMC 4510, MMC 4516 are monolithic integrated circuits available in 16-lead dual in-line plastic package.

The MMC 4510 Presettable BCD Up/Down Counter and MMC 4516 Binary Up/Down Counter consist of four synchronously clocked D-type flip-flops (with a gating structure to provide T-type flip-flop capability) connected as counters. These counters can be cleared by a high level RESET line, and can be preset to any binary number present on the jam inputs by a high level on the PRESET ENABLE line. The MMC 4510 will count out of non-BCD counter states in a maximum of two clock pulses in the up mode, and a maximum of four clock pulses in the down mode. If the CARRY-IN input is held low, the counter advances up or down on each positive-going clock transition. Synchronous cascading is accomplished by

connecting all clock inputs in parallel and connecting the CARRY-OUT of a less significant stage to the CARRY-IN of a more significant stage. The MMC 4510 and MMC 4516 can be cascaded in the ripple mode by connecting the CARRY-OUT to the clock of the next stage. If the UP/DOWN input changes during a terminal count, the CARRY-OUT must be gated with the clock, and the UP/DOWN input must change while the clock is high. This method provides a clean clock signal to the subsequent counting stage.

### FEATURES

- Medium speed operation to 8 MHz typ. at 10 V
- Synchronous internal CARRY propagation
- RESET and PRESET capability

### ABSOLUTE MAXIMUM RATINGS

|            |   |  |               |          |
|------------|---|--|---------------|----------|
| $V_{DD}^*$ | Supply voltage: G and H types<br>E and F types                                  | -0.5 to 20<br>-0.5 to 18<br>-0.5 to $V_{DD}+0.5$ | 20<br>18<br>V | V        |
| $V_i$      | Input voltage   |  | $V_{DD}+0.5$  | V        |
| $I_i$      | DC input current (any one input)  |  | 10            | mA       |
| $P_{tot}$  | Total power dissipation (per package)   |  | 200           | mW       |
|            | Dissipation per output transistor<br>for $T_A$ = full package-temperature range |  | 100           | mW       |
| $T_A$      | Operating<br>temperature : G and H types<br>E and F types                       | -55 to -40 to -65 to                             | 125<br>85     | °C<br>°C |
| $T_{stg}$  | Storage temperature   | -65 to   | 150           | °C       |

\* All voltage values are referred to  $V_{SS}$  pin voltage

### RECOMMENDED OPERATING CONDITIONS

|            |   |               |           |          |
|------------|---|---------------|-----------|----------|
| $V_{DD}^*$ | Supply voltage: G and H types<br>E and F types            | 3 to 3 to     | 18<br>15  | V<br>V   |
| $V_i$      | Input voltage   | 0 to          | $V_{DD}$  | V        |
| $T_A$      | Operating<br>temperature : G and H types<br>E and F types | -55 to -40 to | 125<br>85 | °C<br>°C |

### CONNECTION DIAGRAM

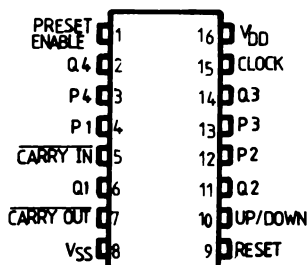

**STATIC ELECTRICAL CHARACTERISTICS**

(over recommended operating conditions)

| PARAMETER                         |                       | TEST CONDITIONS       |                       |                           |                        | VALUES           |       |       |       |                   |                   | UNIT  |      |    |
|-----------------------------------|-----------------------|-----------------------|-----------------------|---------------------------|------------------------|------------------|-------|-------|-------|-------------------|-------------------|-------|------|----|
|                                   |                       | V <sub>I</sub><br>(V) | V <sub>O</sub><br>(V) | I <sub>ol</sub>  <br>(μA) | V <sub>DD</sub><br>(V) | T <sub>LOW</sub> |       | 25°C  |       |                   | T <sub>HIGH</sub> |       |      |    |
|                                   |                       |                       |                       |                           |                        | min.             | max.  | min.  | typ   | max.              | min.              |       | max. |    |
| I <sub>L</sub>                    | Quiescent current     | G, H types            | 0/ 5                  |                           |                        | 5                |       | 5     | 0.04  | 5                 |                   | 150   | μA   |    |
|                                   |                       |                       | 0/10                  |                           |                        | 10               |       | 10    | 0.04  | 10                |                   | 300   |      |    |
|                                   |                       |                       | 0/15                  |                           |                        | 15               |       | 20    | 0.04  | 20                |                   | 600   |      |    |
|                                   |                       |                       | 0/20                  |                           |                        | 20               |       | 100   | 0.08  | 100               |                   | 3000  |      |    |
|                                   | E, F types            | 0/ 5                  |                       |                           | 5                      |                  | 20    | 0.04  | 20    |                   | 150               |       |      |    |
|                                   |                       | 0/10                  |                       |                           | 10                     |                  | 40    | 0.04  | 40    |                   | 300               |       |      |    |
|                                   |                       | 0/15                  |                       |                           | 15                     |                  | 80    | 0.04  | 80    |                   | 600               |       |      |    |
| V <sub>OH</sub>                   | Output high voltage   | 0/ 5                  |                       | < 1                       | 5                      | 4.95             |       | 4.95  |       |                   | 4.95              | V     |      |    |
|                                   |                       | 0/10                  |                       | < 1                       | 10                     | 9.95             |       | 9.95  |       |                   | 9.95              |       |      |    |
|                                   |                       | 0/15                  |                       | < 1                       | 15                     | 14.95            |       | 14.95 |       |                   | 14.95             |       |      |    |
| V <sub>OL</sub>                   | Output low voltage    | 5 /0                  |                       | < 1                       | 5                      |                  | 0.05  |       |       | 0.05              |                   | 0.05  | V    |    |
|                                   |                       | 10/0                  |                       | < 1                       | 10                     |                  | 0.05  |       |       | 0.05              |                   | 0.05  |      |    |
|                                   |                       | 15/0                  |                       | < 1                       | 15                     |                  | 0.05  |       |       | 0.05              |                   | 0.05  |      |    |
| V <sub>IH</sub>                   | input high voltage    |                       | 0.5/4.5               | < 1                       | 5                      | 3.5              |       | 3.5   |       |                   | 3.5               | V     |      |    |
|                                   |                       |                       | 1/9                   | < 1                       | 10                     | 7                |       | 7     |       |                   | 7                 |       |      |    |
|                                   |                       |                       | 1.5/13.5              | < 1                       | 15                     | 11               |       | 11    |       |                   | 11                |       |      |    |
| V <sub>IL</sub>                   | Input low voltage     |                       | 4.5/0.5               | < 1                       | 5                      |                  | 1.5   |       |       | 1.5               |                   | 1.5   | V    |    |
|                                   |                       |                       | 9/1                   | < 1                       | 10                     |                  | 3     |       |       | 3                 |                   | 3     |      |    |
|                                   |                       |                       | 13.5/1.5              | < 1                       | 15                     |                  | 4     |       |       | 4                 |                   | 4     |      |    |
| I <sub>OH</sub>                   | Output drive current  | G, H types            | 0/ 5                  | 2.5                       |                        | 5                | -2    |       | -1.6  | -3.2              |                   | -1.15 | mA   |    |
|                                   |                       |                       | 0/ 5                  | 4.6                       |                        | 5                | -0.64 |       | -0.51 | -1                |                   | -0.36 |      |    |
|                                   |                       |                       | 0/10                  | 9.5                       |                        | 10               | -1.6  |       | -1.3  | -2.6              |                   | -0.9  |      |    |
|                                   |                       |                       | 0/15                  | 13.5                      |                        | 15               | -4.2  |       | -3.4  | -6.8              |                   | -2.4  |      |    |
|                                   |                       | E, F types            | 0/ 5                  | 2.5                       |                        | 5                | -1.53 |       | -1.36 | -3.2              |                   | -1.1  |      |    |
|                                   |                       |                       | 0/ 5                  | 4.6                       |                        | 5                | -0.52 |       | -0.44 | -1                |                   | -0.36 |      |    |
|                                   |                       | 0/10                  | 9.5                   |                           | 10                     | -1.3             |       | -1.1  | -2.6  |                   | -0.9              |       |      |    |
|                                   |                       | 0/15                  | 13.5                  |                           | 15                     | -3.6             |       | -3.0  | -6.8  |                   | -2.4              |       |      |    |
| I <sub>OL</sub>                   | Output sink current   | G, H types            | 0/ 5                  | 0.4                       |                        | 5                | 0.64  |       | 0.51  | 1                 |                   | 0.36  | mA   |    |
|                                   |                       |                       | 0/10                  | 0.5                       |                        | 10               | 1.6   |       | 1.3   | 2.6               |                   | 0.9   |      |    |
|                                   |                       |                       | 0/15                  | 1.5                       |                        | 15               | 4.2   |       | 3.4   | 6.8               |                   | 2.4   |      |    |
|                                   |                       | E, F types            | 0/ 5                  | 0.4                       |                        | 5                | 0.52  |       | 0.44  | 1                 |                   | 0.36  |      |    |
|                                   |                       |                       | 0/10                  | 0.5                       |                        | 10               | 1.3   |       | 1.1   | 2.6               |                   | 0.9   |      |    |
|                                   |                       |                       | 0/15                  | 1.5                       |                        | 15               | 3.6   |       | 3.0   | 6.8               |                   | 2.4   |      |    |
| I <sub>IH</sub> , I <sub>IL</sub> | Input leakage current | G, H types            | 0/18                  | Any input                 |                        | 18               |       | ±0.1  |       | ±10 <sup>-5</sup> | ±0.1              |       | ±1   | μA |
|                                   |                       | E, F types            | 0/15                  |                           |                        | 15               |       | ±0.3  |       | ±10 <sup>-5</sup> | ±0.3              |       | ±1   |    |
| C <sub>i</sub>                    | Input capacitance     |                       | Any input             |                           |                        |                  |       |       | 5     | 7.5               |                   |       | pF   |    |

\* T<sub>LOW</sub> = -55°C for G, H devices; -40°C for E, F devices.

\* T<sub>HIGH</sub> = +125°C for G, H devices; +85°C for E, F devices.

The Noise Margin for both "1" and "0" level is:

- 1 V min. with V<sub>DD</sub> = 5 V
- 2 V min. with V<sub>DD</sub> = 10 V
- 2.5 V min. with V<sub>DD</sub> = 15 V

**DYNAMIC ELECTRICAL CHARACTERISTICS**

( $T_{amb} = 25\text{ }^{\circ}\text{C}$ ,  $C_L = 50\text{ pF}$ ,  $R_L = 200\text{ k}$ , typical temperature coefficient for all  $V_{DD}$  values is  $0.3\%/^{\circ}\text{C}$ , all input rise and fall times =  $20\text{ ns}$ )

| PARAMETER              | TEST CONDITIONS<br>$V_{DD}$ (V)                     | VALUES        |                   |                   | UNIT |
|------------------------|---|---------------|-------------------|-------------------|------|
|                        |   | MIN.          | TYP.              | MAX.              |      |
| $t_{PLH}$<br>$t_{PLH}$ | Propagation delay time Clock to Q                   | 5<br>10<br>15 | 200<br>100<br>75  | 400<br>200<br>150 | ns   |
| $t_{PHL}$<br>$t_{PLH}$ | Propagation delay time preset or reset to Q output  | 5<br>10<br>15 | 210<br>105<br>80  | 420<br>210<br>160 | ns   |
| $t_{XHL}$<br>$t_{PLH}$ | Propagation delay time clock to carry out           | 5<br>10<br>15 | 240<br>120<br>90  | 480<br>240<br>180 | ns   |
| $t_{PHL}$<br>$t_{PLH}$ | Propagation delay time carry in to carry out        | 5<br>10<br>15 | 125<br>60<br>50   | 250<br>120<br>100 | ns   |
| $t_{PHL}$<br>$t_{PLH}$ | Propagation delay time preset or reset to carry out | 5<br>10<br>15 | 320<br>160<br>125 | 640<br>320<br>250 | ns   |
| $t_{TLH}$<br>$t_{THL}$ | Transition time                                     | 5<br>10<br>15 | 100<br>50<br>40   | 200<br>100<br>80  | ns   |
| $f_{max}$              | Max. clock frequency                                | 5<br>10<br>15 | 2<br>4<br>5.5     | 4<br>8<br>11      | MHz  |
| $t_w$                  | Clock pulse width                                   | 5<br>10<br>15 | 150<br>75<br>60   |                   | ns   |
|                        | (*) Preset enable or removal time                   | 5<br>10<br>15 | 150<br>80<br>60   |                   | ns   |
| $t_r$<br>$t_f$         | * Clock rise and fall time                          | 5<br>10<br>15 |                   | 15<br>5<br>5      | ns   |
| $t_{setup}$            | Carry in setup time                                 | 5<br>10<br>15 | 130<br>60<br>45   |                   | ns   |
| $t_{setup}$            | Up-down setup time                                  | 5<br>10<br>15 | 360<br>160<br>110 |                   | ns   |
| $t_w$                  | Preset enable or reset pulse width                  | 5<br>10<br>15 | 220<br>100<br>75  |                   | ns   |

\* Time required after the falling edge of the reset or preset enable inputs before the rising edge of the clock will trigger the counter (similar to setup time).  
If more than unit is cascaded in the parallel clocked application,  $t_r$  clock should be made less than or equal to the sum of the fixed propagation delay at  $15\text{ pF}$  and the transition time of the carry output driving stage for the estimated capacitive load.

**LOGIC DIAGRAM**

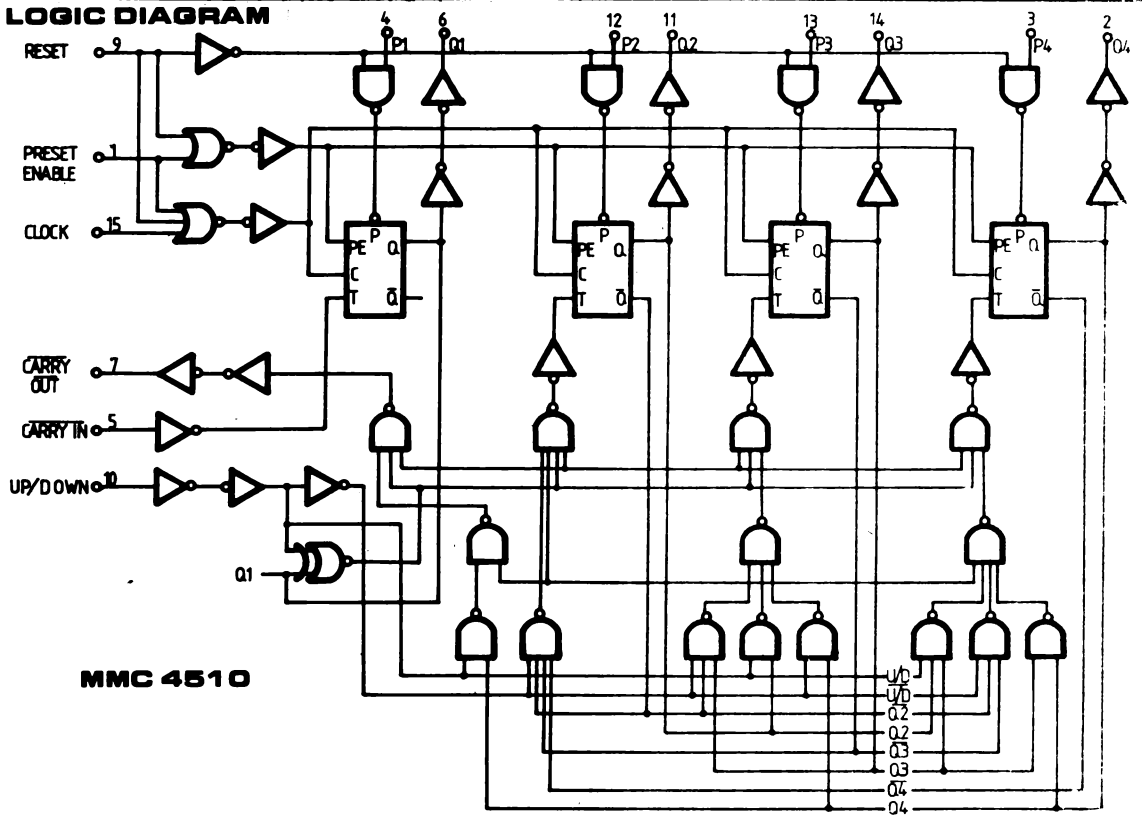

**MMC 4510**

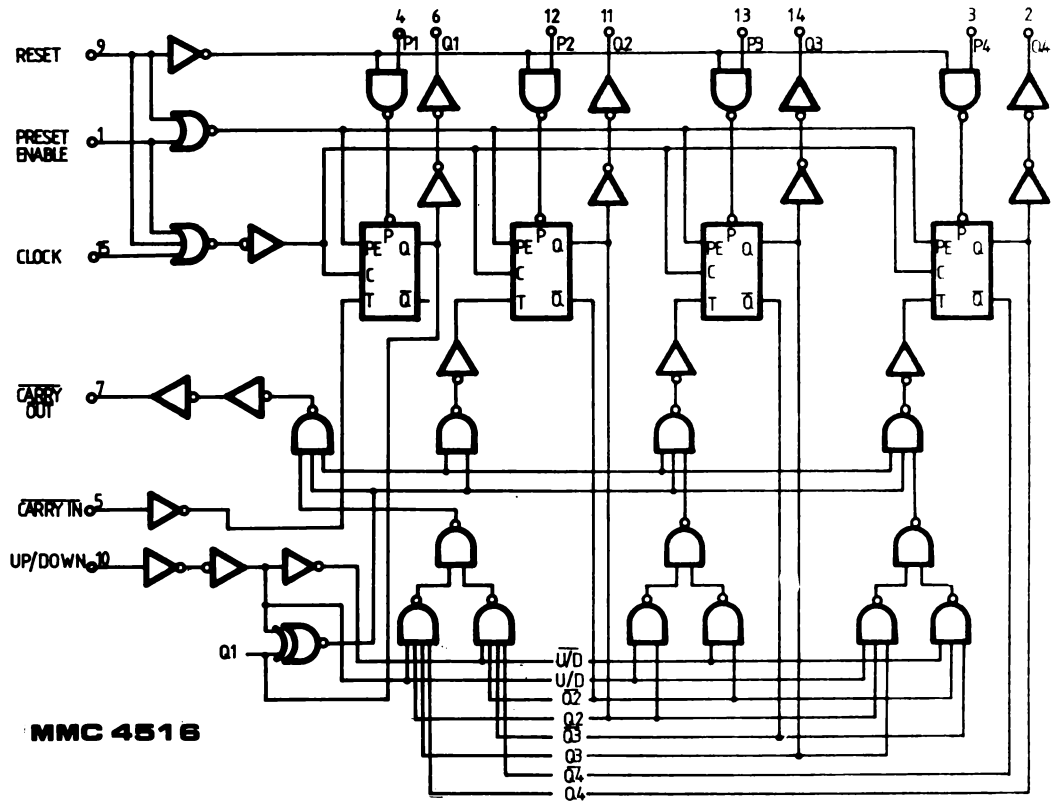

**MMC 4516**

**TIMING DIAGRAMS**

**MMC 4510**

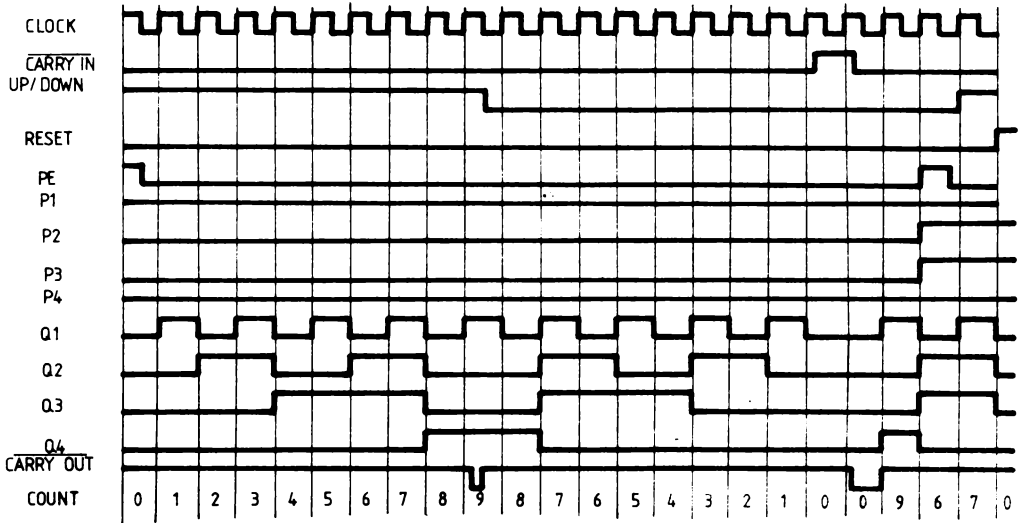

**TRUTH TABLE**

| CL | CI | U/D | PE | R | ACTION     |
|----|----|-----|----|---|------------|
| X  | 1  | X   | 0  | 0 | NO COUNT   |
|    | 0  | 1   | 0  | 0 | COUNT UP   |
|    | 0  | 0   | 0  | 0 | COUNT DOWN |
| X  | X  | X   | 1  | 0 | PRESET     |
| X  | X  | X   | X  | 1 | RESET      |

X = Don't care

**TIMING DIAGRAM**

**MMC 4516**

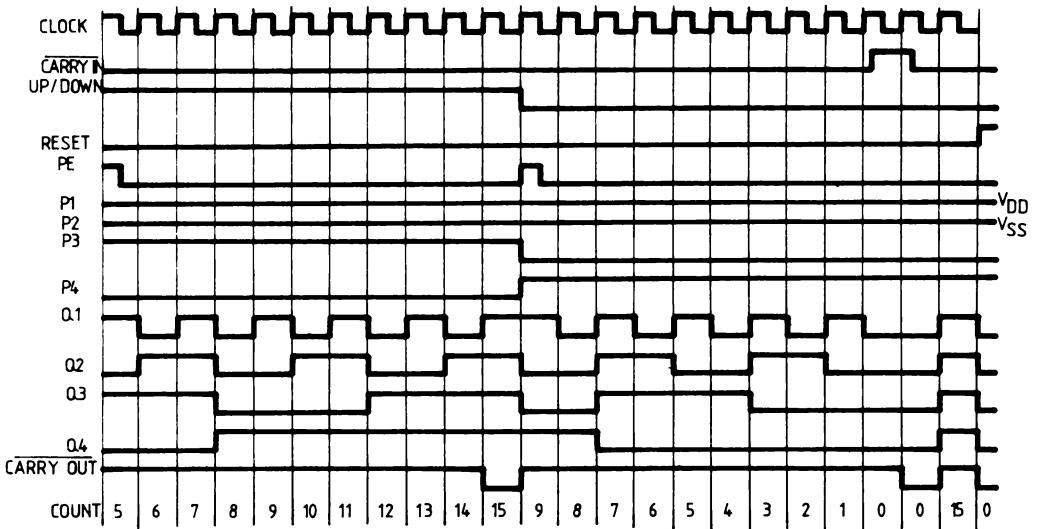



TYPICAL APPLICATIONS

Typical 16-channel 10 bit data acquisition system

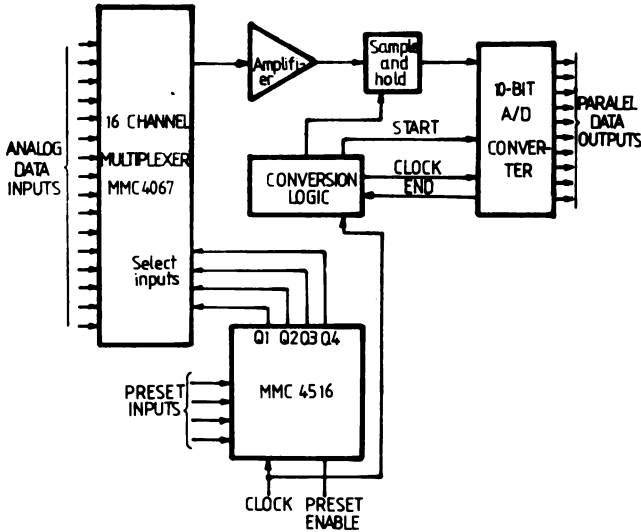

This acquisition system can be operated in the random access mode by jamming in the channel number at the present inputs, or in the sequential mode by clocking the MMC 4516.

Cascading counter packages

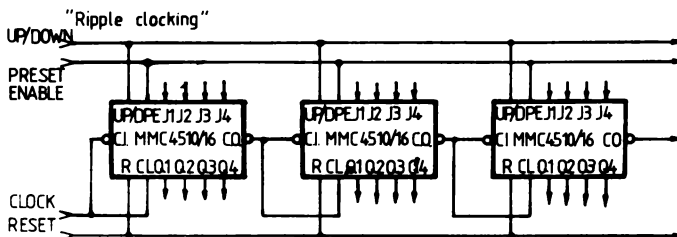
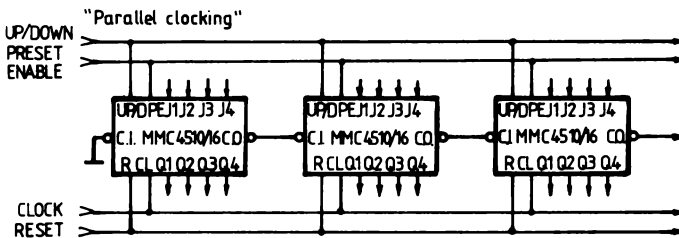

# BCD-TO-SEVEN SEGMENT LATCH/ DECODER/DRIVER

## GENERAL DESCRIPTION

The MMC 4511 is a monolithic integrated circuit available in 16-lead dual in-line plastic or ceramic package.

The MMC 4511 type is a BCD-to-7-segment latch decoder driver constructed with COS/MOS logic and n-p-n bipolar transistor output devices on a single monolithic structure. This device combines the low quiescent power dissipation and high noise immunity features of COS/MOS with n-p-n bipolar output capable of sourcing up to 25 mA. This capability allows the MMC 4511 type to drive LED's and other displays directly. Lamp Test (LT), Blanking (BL) and Latch Enable or Strobe inputs are provided to test the display, shut off or intensity-modulate it, and store or strobe a BCD code, respectively. Several different signals may be multiplexed and displayed when external multiplexing circuitry is used.

## FEATURES

- High-output-sourcing capability (up to 25mA)
- Input latches for BCD code storage
- Lamp test and blanking capability
- 7-segment outputs blanked for BCD input codes > 1001

## APPLICATION

- Interfacing with various displays
- Driving common-cathode 7-segment LED displays
- Driving low-voltage fluorescent displays
- Driving incandescent displays.

## ABSOLUTE MAXIMUM RATINGS

|            |   |                    |              |          |
|------------|---|--------------------|--------------|----------|
| $V_{DD}^*$ | Supply voltage: G and H types<br>E and F types  | -0.5 to<br>-0.5 to | 20<br>18     | V<br>V   |
| $V_i$      | Input voltage   | -0.5 to            | $V_{DD}+0.5$ | V        |
| $I_i$      | DC input current (any one input)  |                    | $\pm 10$     | mA       |
| $P_{tot}$  | Total power dissipation (per package)<br>Dissipation per output transistor<br>for $T_A$ = full package-temperature range. |                    | 200          | mW       |
| $T_A$      | Operating<br>temperature : G and H types<br>E and F types   | -55 to<br>-40 to   | 125<br>85    | °C<br>°C |
| $T_{stg}$  | Storage temperature   | -65 to             | 150          | °C       |

\* All voltage values are referred to  $V_{SS}$  pin voltage

## RECOMMENDED OPERATING CONDITIONS

|            |   |                  |           |          |
|------------|---|------------------|-----------|----------|
| $V_{DD}^*$ | Supply voltage: G and H types<br>E and F types            | 3 to<br>3 to     | 18<br>15  | V<br>V   |
| $V_i$      | Input voltage   | 0 to             | $V_{DD}$  | V        |
| $T_A$      | Operating<br>temperature : G and H types<br>E and F types | -55 to<br>-40 to | 125<br>85 | °C<br>°C |

## CONNECTION DIAGRAM

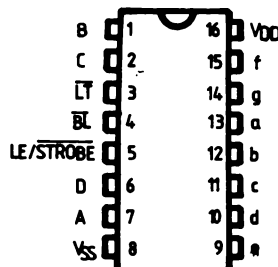

LOGIC DIAGRAM

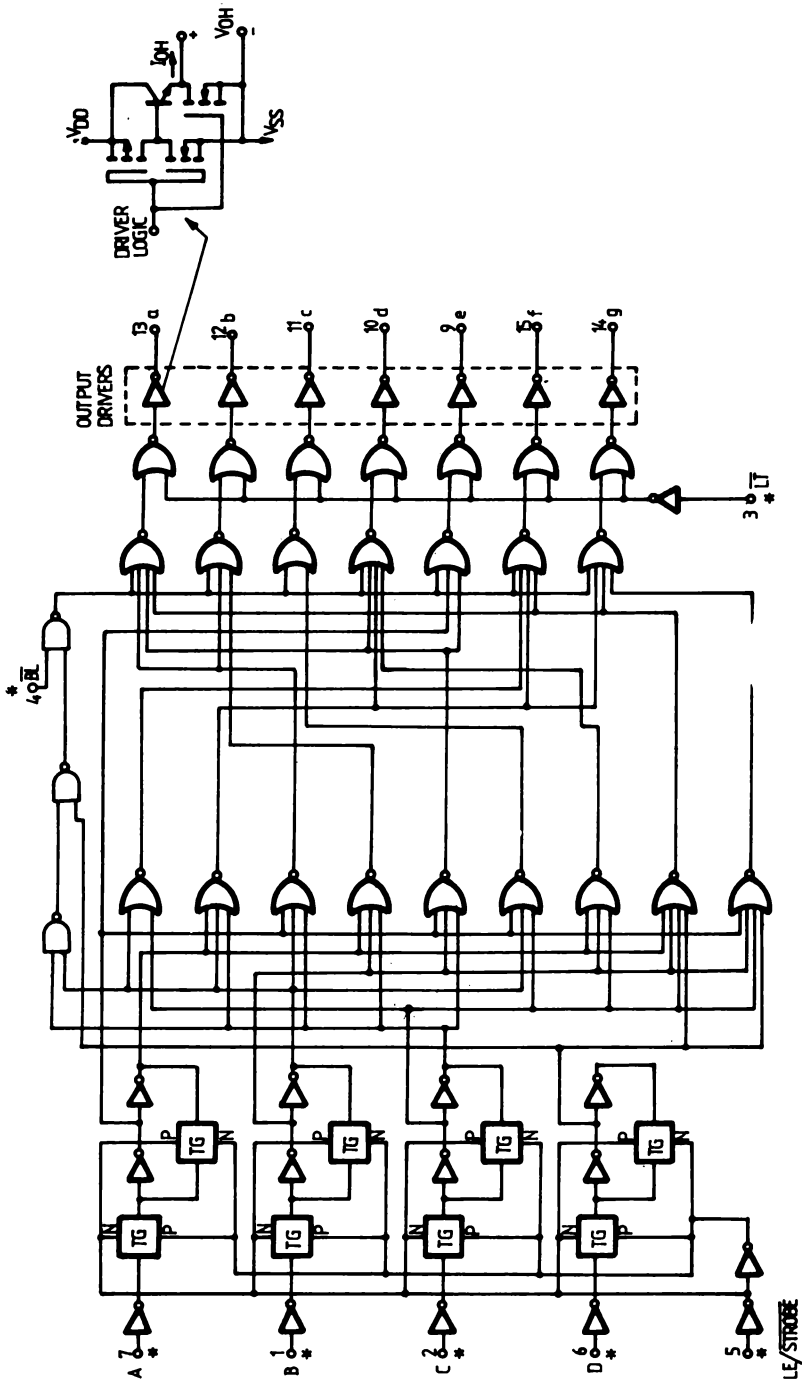

**TRUTH TABLE**

| LE | Bi | LT | D | C | B | A | a | b | c | d | e | f | g | Display  |
|----|----|----|---|---|---|---|---|---|---|---|---|---|---|----------|
| X  | X  | 0  | X | X | X | X | 1 | 1 | 1 | 1 | 1 | 1 | 1 | <b>8</b> |
| X  | 0  | 1  | X | X | X | X | 0 | 0 | 0 | 0 | 0 | 0 | 0 | Blank    |
| 0  | 1  | 1  | 0 | 0 | 0 | 0 | 1 | 1 | 1 | 1 | 1 | 1 | 0 | <b>0</b> |
| 0  | 1  | 1  | 0 | 0 | 0 | 1 | 0 | 1 | 1 | 0 | 0 | 0 | 0 | <b>1</b> |
| 0  | 1  | 1  | 0 | 0 | 1 | 0 | 1 | 1 | 0 | 1 | 1 | 0 | 1 | <b>2</b> |
| 0  | 1  | 1  | 0 | 0 | 1 | 1 | 1 | 1 | 1 | 1 | 0 | 0 | 1 | <b>3</b> |
| 0  | 1  | 1  | 0 | 1 | 0 | 0 | 0 | 1 | 1 | 0 | 0 | 1 | 1 | <b>4</b> |
| 0  | 1  | 1  | 0 | 1 | 0 | 1 | 1 | 0 | 1 | 1 | 0 | 1 | 1 | <b>5</b> |
| 0  | 1  | 1  | 0 | 1 | 1 | 0 | 0 | 0 | 1 | 1 | 1 | 1 | 1 | <b>6</b> |
| 0  | 1  | 1  | 0 | 1 | 1 | 1 | 1 | 1 | 1 | 0 | 0 | 0 | 0 | <b>7</b> |
| 0  | 1  | 1  | 1 | 0 | 0 | 0 | 1 | 1 | 1 | 1 | 1 | 1 | 1 | <b>8</b> |
| 0  | 1  | 1  | 1 | 0 | 0 | 1 | 1 | 1 | 1 | 0 | 0 | 1 | 1 | <b>9</b> |
| 0  | 1  | 1  | 1 | 0 | 1 | 0 | 0 | 0 | 0 | 0 | 0 | 0 | 0 | Blank    |
| 0  | 1  | 1  | 1 | 0 | 1 | 1 | 0 | 0 | 0 | 0 | 0 | 0 | 0 | Blank    |
| 0  | 1  | 1  | 1 | 1 | 0 | 0 | 0 | 0 | 0 | 0 | 0 | 0 | 0 | Blank    |
| 0  | 1  | 1  | 1 | 1 | 0 | 1 | 0 | 0 | 0 | 0 | 0 | 0 | 0 | Blank    |
| 0  | 1  | 1  | 1 | 1 | 1 | 0 | 0 | 0 | 0 | 0 | 0 | 0 | 0 | Blank    |
| 0  | 1  | 1  | 1 | 1 | 1 | 1 | 0 | 0 | 0 | 0 | 0 | 0 | 0 | Blank    |
| 1  | 1  | 1  | X | X | X | X |   |   |   | * |   |   |   | *        |

X = Don't care

\* = Depends on BCD code previously applied when LE = 0

Note : Display is blank for all illegal input codes (BCD > 1001)

**WAVEFORMS**

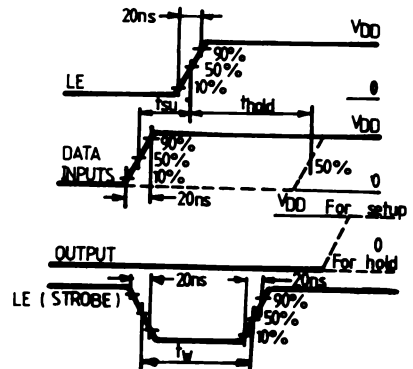
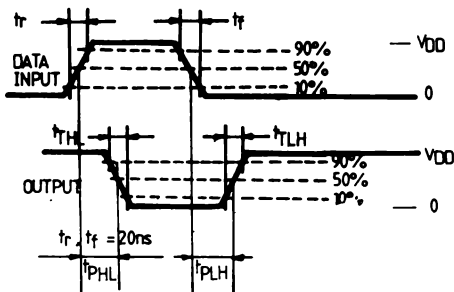

**STATIC ELECTRICAL CHARACTERISTICS**

(over recommended operating conditions)

| PARAMETER       |                      | TEST CONDITIONS       |                       |                          |                        | VALUES           |      |      |       |       |                   | UNIT |      |  |
|-----------------|----------------------|-----------------------|-----------------------|--------------------------|------------------------|------------------|------|------|-------|-------|-------------------|------|------|--|
|                 |                      | V <sub>I</sub><br>(V) | V <sub>O</sub><br>(V) | I <sub>O</sub>  <br>(μA) | V <sub>DD</sub><br>(V) | T <sub>LOW</sub> |      | 25°C |       |       | T <sub>HIGH</sub> |      |      |  |
|                 |                      |                       |                       |                          |                        | min.             | max. | min. | typ   | max.  | min.              |      | max. |  |
| I <sub>L</sub>  | Quiescent current    | G, H types            | 0/ 5                  |                          |                        | 5                |      | 5    |       | 0.04  | 5                 |      | 150  |  |
|                 |                      |                       | 0/10                  |                          |                        | 10               |      | 10   |       | 0.04  | 10                |      | 300  |  |
|                 |                      |                       | 0/15                  |                          |                        | 15               |      | 20   |       | 0.04  | 20                |      | 600  |  |
|                 |                      |                       | 0/20                  |                          |                        | 20               |      | 100  |       | 0.08  | 100               |      | 3000 |  |
|                 | E, F types           | 0/ 5                  |                       |                          | 5                      |                  | 20   |      | 0.04  | 20    |                   | 150  |      |  |
|                 |                      | 0/10                  |                       |                          | 10                     |                  | 40   |      | 0.04  | 40    |                   | 300  |      |  |
|                 | 0/15                 |                       |                       | 15                       |                        | 80               |      | 0.04 | 80    |       | 600               |      |      |  |
| V <sub>OH</sub> | Output high voltage  |                       |                       |                          | 5                      | 4                |      | 4.1  | 4.55  |       | 4.2               |      | V    |  |
|                 |                      | 0/10                  |                       |                          | 10                     | 9                |      | 9.1  | 9.55  |       | 9.2               |      |      |  |
|                 |                      | 0/15                  |                       |                          | 15                     | 14               |      | 14.1 | 14.55 |       | 14.2              |      |      |  |
| V <sub>OL</sub> | Output low voltage   | 5 /0                  |                       | < 1                      | 5                      |                  | 0.05 |      |       | 0.05  |                   | 0.05 | V    |  |
|                 |                      | 10/0                  |                       | < 1                      | 10                     |                  | 0.05 |      |       | 0.05  |                   | 0.05 |      |  |
|                 |                      | 15/0                  |                       | < 1                      | 15                     |                  | 0.05 |      |       | 0.05  |                   | 0.05 |      |  |
| V <sub>IH</sub> | Input high voltage   |                       | 0.5/4.5               | < 1                      | 5                      | 3.5              |      | 3.5  |       |       | 3.5               |      | V    |  |
|                 |                      |                       | 1/9                   | < 1                      | 10                     | 7                |      | 7    |       |       | 7                 |      |      |  |
|                 |                      |                       | 1.5/13.5              | < 1                      | 15                     | 11               |      | 11   |       |       | 11                |      |      |  |
| V <sub>IL</sub> | Input low voltage    |                       | 4.5/0.5               | < 1                      | 5                      |                  | 1.5  |      |       | 1.5   |                   | 1.5  | V    |  |
|                 |                      |                       | 9/1                   | < 1                      | 10                     |                  | 3    |      |       | 3     |                   | 3    |      |  |
|                 |                      |                       | 13.5/1.5              | < 1                      | 15                     |                  | 4    |      |       | 4     |                   | 4    |      |  |
| V <sub>OH</sub> | Output drive voltage | G, H types            |                       | 0                        |                        | 4.1              |      | 4.1  | 4.55  |       | 4.2               |      |      |  |
|                 |                      |                       |                       | 5                        |                        | 5                |      | 3.8  | 4.25  |       | 3.9               |      |      |  |
|                 |                      |                       |                       | 10                       |                        | 10               |      | 3.9  | 4.10  |       | 3.9               |      |      |  |
|                 |                      |                       |                       | 15                       |                        | 15               |      | 3.55 | 3.95  |       |                   |      |      |  |
|                 |                      |                       |                       | 20                       |                        | 20               |      | 3.4  | 3.75  |       |                   |      |      |  |
|                 |                      |                       |                       | 25                       |                        | 25               |      | 3.4  | 3.55  |       |                   |      |      |  |
|                 |                      |                       |                       |                          | 0                      |                  | 9    |      | 9.1   | 9.55  |                   | 9.2  |      |  |
|                 |                      |                       |                       |                          | 5                      |                  | 10   |      | 8.85  | 9.25  |                   | 8.4  |      |  |
|                 |                      |                       |                       |                          | 10                     |                  | 10   |      | 9     | 9.15  |                   |      |      |  |
|                 |                      |                       |                       |                          | 15                     |                  | 15   |      | 8.7   | 9.05  |                   |      |      |  |
|                 |                      |                       |                       |                          | 20                     |                  | 20   |      | 8.6   | 8.9   |                   |      |      |  |
|                 |                      |                       |                       |                          | 25                     |                  | 25   |      | 8.6   | 8.75  |                   |      |      |  |
|                 |                      |                       |                       |                          | 0                      |                  | 14   |      | 14.1  | 14.55 |                   | 14.2 |      |  |
|                 |                      |                       |                       |                          | 5                      |                  | 15   |      | 13.9  | 14.3  |                   | 14.0 |      |  |
|                 |                      |                       |                       |                          | 10                     |                  | 10   |      | 13.75 | 14.2  |                   |      |      |  |
|                 |                      |                       |                       |                          | 15                     |                  | 15   |      | 13.7  | 14.1  |                   |      |      |  |
|                 |                      |                       |                       |                          | 20                     |                  | 20   |      | 13.75 | 13.95 |                   |      |      |  |
|                 |                      |                       |                       |                          | 25                     |                  | 25   |      | 13.65 | 13.8  |                   |      |      |  |
|                 | E, F types           |                       |                       | 0                        |                        | 4.1              |      | 4.1  | 4.57  |       | 4.1               |      |      |  |
|                 |                      |                       |                       | 5                        |                        | 5                |      | 3.6  | 4.24  |       | 3.3               |      |      |  |
|                 |                      |                       |                       | 10                       |                        | 10               |      | 3.6  | 4.12  |       | 2.5               |      |      |  |
|                 |                      |                       |                       | 15                       |                        | 15               |      | 2.8  | 3.94  |       |                   |      |      |  |
|                 |                      |                       |                       | 20                       |                        | 20               |      | 2.8  | 3.75  |       |                   |      |      |  |
|                 |                      |                       |                       | 25                       |                        | 25               |      | 2.8  | 3.54  |       |                   |      |      |  |
|                 |                      |                       |                       | 0                        |                        | 9.1              |      | 9.1  | 9.58  |       | 9.1               |      |      |  |
|                 |                      |                       |                       | 5                        |                        | 10               |      | 8.75 | 9.26  |       | 8.45              |      |      |  |
|                 |                      |                       |                       | 10                       |                        | 10               |      | 8.75 | 9.17  |       |                   |      |      |  |
|                 |                      |                       |                       | 15                       |                        | 15               |      | 8.1  | 9.04  |       |                   |      |      |  |
|                 |                      |                       |                       | 20                       |                        | 20               |      | 8.1  | 8.9   |       |                   |      |      |  |
|                 |                      |                       |                       | 25                       |                        | 25               |      | 8.1  | 8.75  |       |                   |      |      |  |

**STATIC ELECTRICAL CHARACTERISTICS**

(over recommended operating conditions)

| PARAMETER                       |                       | TEST CONDITIONS       |                       |                          |                        | VALUES           |      |       |       |                   |                   | UNIT |       |    |
|---------------------------------|-----------------------|-----------------------|-----------------------|--------------------------|------------------------|------------------|------|-------|-------|-------------------|-------------------|------|-------|----|
|                                 |                       | V <sub>I</sub><br>(V) | V <sub>O</sub><br>(V) | I <sub>O</sub>  <br>(μA) | V <sub>DD</sub><br>(V) | T <sub>LOW</sub> |      | 25°C  |       |                   | T <sub>HIGH</sub> |      |       |    |
|                                 |                       |                       |                       |                          |                        | min.             | max. | min.  | typ.  | max.              | min.              |      | max.  |    |
|                                 | E, F types            |                       |                       | 0                        | 15                     | 14.1             |      | 14.1  | 14.59 |                   | 14.1              | V    |       |    |
|                                 |                       |                       |                       | 5                        |                        |                  |      | 14.27 |       |                   |                   |      |       |    |
|                                 |                       |                       |                       | 10                       |                        | 13.75            |      | 13.75 |       | 14.18             |                   |      | 13.45 |    |
|                                 |                       |                       |                       | 15                       |                        |                  |      | 13.1  |       | 14.07             |                   |      |       |    |
|                                 |                       |                       |                       | 20                       |                        |                  |      |       |       | 13.95             |                   |      |       |    |
| I <sub>OL</sub>                 | Output sink current   | G, H types            | 0/ 5                  | 0.4                      |                        | 5                | 0.64 |       | 0.51  | 1                 |                   | 0.36 | mA    |    |
|                                 |                       |                       | 0/10                  | 0.5                      |                        | 10               | 1.6  |       | 1.3   | 2.6               |                   | 0.9  |       |    |
|                                 |                       |                       | 0/15                  | 1.5                      |                        | 15               | 4.2  |       | 3.4   | 6.8               |                   | 2.4  |       |    |
|                                 | E, F types            | 0/ 5                  | 0.4                   |                          | 5                      | 0.52             |      | 0.44  | 1     |                   | 0.36              |      |       |    |
|                                 |                       | 0/10                  | 0.5                   |                          | 10                     | 1.3              |      | 1.1   | 2.6   |                   | 0.9               |      |       |    |
|                                 |                       | 0/15                  | 1.5                   |                          | 15                     | 3.6              |      | 3.0   | 6.8   |                   | 2.4               |      |       |    |
| I <sub>IH</sub> I <sub>IL</sub> | Input leakage current | G, H types            | 0/18                  | Any input                |                        | 18               |      | ±0.1  |       | ±10 <sup>-5</sup> | ±0.1              |      | ±1    | μA |
|                                 |                       | E, F types            | 0/15                  |                          |                        | 15               |      | ±0.3  |       | ±10 <sup>-5</sup> | ±0.3              |      | ±1    |    |
| C <sub>i</sub>                  | Input capacitance     |                       | Any input             |                          |                        |                  |      |       | 5     | 7.5               |                   |      | pF    |    |

\* T<sub>LOW</sub> = -55°C for G, H devices; -40°C for E, F devices.  
 \* T<sub>HIGH</sub> = +125°C for G, H devices; +85°C for E, F devices.

The Noise Margin for both "1" and "0" level is:  
 1 V min. with V<sub>DD</sub> = 5 V  
 2 V min. with V<sub>DD</sub> = 10 V  
 2.5 V min. with V<sub>DD</sub> = 15 V

**DYNAMIC ELECTRICAL CHARACTERISTICS**

(T<sub>A</sub> = 25°C, C<sub>L</sub> = 50 pF, R<sub>L</sub> = 200 kΩ, typical temperature coefficient for all V<sub>DD</sub> values is 0.3%/°C, all input rise and fall times = 20 ns)

| PARAMETER        |  | TEST CONDITIONS | VALUES              |      |      | UNIT |
|------------------|--|-----------------|---------------------|------|------|------|
|                  |  |                 | V <sub>DD</sub> (V) | min. | typ. |      |
| t <sub>PHL</sub> | Propagation delay time (Data)              | 5               |                     | 520  | 1040 | ns   |
|                  |  | 10              |                     | 210  | 420  |      |
|                  |  | 15              |                     | 150  | 300  |      |
| t <sub>PLH</sub> | Propagation delay time (Data)              | 5               |                     | 660  | 1320 | ns   |
|                  |  | 10              |                     | 260  | 520  |      |
|                  |  | 15              |                     | 180  | 360  |      |
| t <sub>PHL</sub> | Propagation delay time ( $\overline{B}$ )  | 5               |                     | 350  | 700  | ns   |
|                  |  | 10              |                     | 175  | 350  |      |
|                  |  | 15              |                     | 150  | 300  |      |
| t <sub>PLH</sub> | Propagation delay time ( $\overline{B}$ )  | 5               |                     | 400  | 800  | ns   |
|                  |  | 10              |                     | 175  | 350  |      |
|                  |  | 15              |                     | 150  | 300  |      |
| t <sub>PHL</sub> | Propagation delay time ( $\overline{LT}$ ) | 5               |                     | 250  | 500  | ns   |
|                  |  | 10              |                     | 125  | 250  |      |
|                  |  | 15              |                     | 85   | 170  |      |
| t <sub>PLH</sub> | Propagation delay time ( $\overline{LT}$ ) | 5               |                     | 150  | 300  | ns   |
|                  |  | 10              |                     | 75   | 150  |      |
|                  |  | 15              |                     | 50   | 100  |      |

| PARAMETER                 | TEST CONDITIONS | VALUES |      |      | UNIT |
|---------------------------|-----------------|--------|------|------|------|
|                           |                 | VDD(V) | min. | typ. |      |
| $t_{TLH}$ Transition time | 5<br>10<br>15   |        | 40   | 80   | ns   |
|                           |                 |        | 30   | 60   |      |
|                           |                 |        | 20   | 50   |      |
| $t_{THL}$ Transition time | 5<br>10<br>15   |        | 125  | 310  | ns   |
|                           |                 |        | 75   | 185  |      |
|                           |                 |        | 65   | 160  |      |
| $t_{setup}$ Setup time    | 5<br>10<br>15   | 150    | 75   | ns   |      |
|                           |                 | 70     | 35   |      |      |
|                           |                 | 40     | 20   |      |      |
| $t_{hold}$ Hold time      | 5<br>10<br>15   | 0      | -75  | ns   |      |
|                           |                 | 0      | -35  |      |      |
|                           |                 | 0      | -20  |      |      |
| $t_W$ Strobe pulse width  | 5<br>10<br>15   | 400    | 200  | ns   |      |
|                           |                 | 160    | 80   |      |      |
|                           |                 | 100    | 50   |      |      |

**APPLICATION**

Driving common-cathode 7-segment LED displays

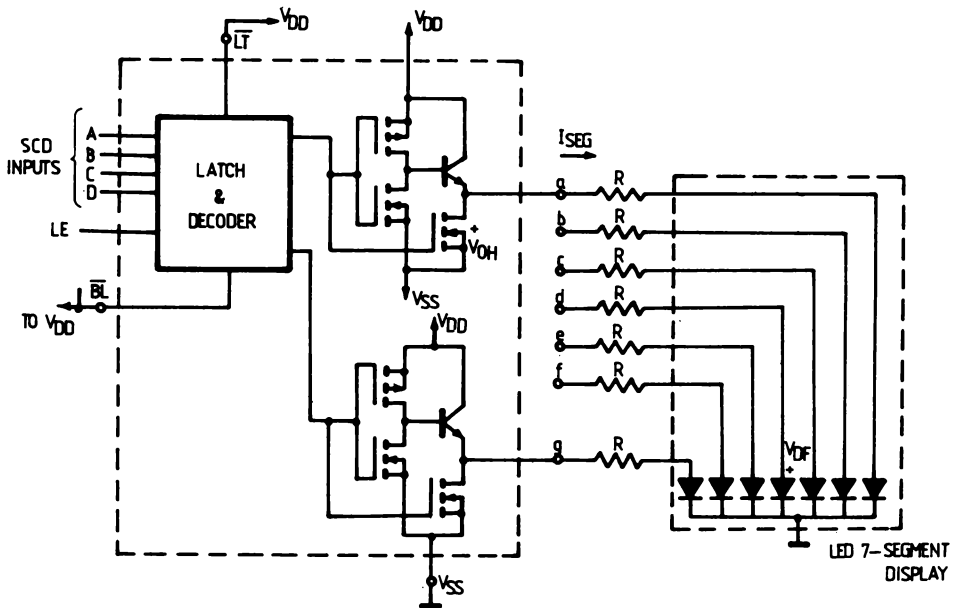

# DUAL UP-COUNTERS: MMC 4518 DUAL BCD UP-COUNTER MMC 4520 DUAL BINARY UP-COUNTER

## GENERAL DESCRIPTION

The MMC 4518/4520 are monolithic integrated circuits available in 16-lead dual in-line plastic package. The MMC 4518 Dual BCD Up Counter and MMC 4520 Dual Binary Up Counter each consist of two identical, internally synchronous 4-stage counters. The counter stages are D-type flip-flops having interchangeable Clock and Enable lines for incrementing on either the positive-going or negative-going transition. For single-unit operation the Enable input is maintained „high“ and the counter advances on each positive-going transition of the Clock. The counters are cleared by high levels on their Reset lines. The counter can be cascaded in the ripple mode by connecting Q4 to the Enable input of the subsequent counter while the clock input of the latter is held low.

## FEATURES

- Medium-speed operation-6 MHz typ. clock frequency at 10 V
- Positive or negative edge triggering
- Synchronous internal CARRY propagation

## ABSOLUTE MAXIMUM RATINGS

|            |  |  |                            |
|------------|--|--|----------------------------|
| $V_{DD}^*$ | Supply voltage: G and H types<br>E and F types                               | -0.5 to 20<br>-0.5 to 18<br>-0.5 to $V_{DD}+0.5$ | V<br>V<br>V                |
| $V_i$      | Input voltage  |  | V                          |
| $I_i$      | DC input current (any one input)   |  | $\pm 10$ mA                |
| $P_{tot}$  | Total power dissipation (per package)  |  | 200 mW                     |
|            | Dissipation per output transistor for $T_A$ = full package-temperature range |  | 100 mW                     |
| $T_A$      | Operating temperature : G and H types<br>E and F types                       | -55 to 125<br>-40 to 85                          | $^{\circ}C$<br>$^{\circ}C$ |
| $T_{stg}$  | Storage temperature  | -65 to 150                                       | $^{\circ}C$                |

\* All voltage values are referred to  $V_{SS}$  pin voltage

## RECOMMENDED OPERATING CONDITIONS

|            |  |                                     |                            |
|------------|--|-------------------------------------|----------------------------|
| $V_{DD}^*$ | Supply voltage: G and H types<br>E and F types         | 3 to 18<br>3 to 15<br>0 to $V_{DD}$ | V<br>V<br>V                |
| $V_i$      | Input voltage  |                                     | V                          |
| $T_A$      | Operating temperature : G and H types<br>E and F types | -55 to 125<br>-40 to 85             | $^{\circ}C$<br>$^{\circ}C$ |

## CONNECTION DIAGRAM

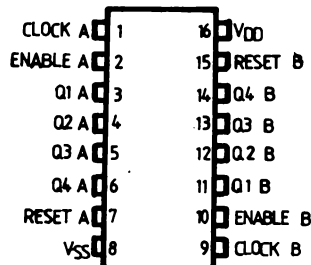



LOGIC DIAGRAM



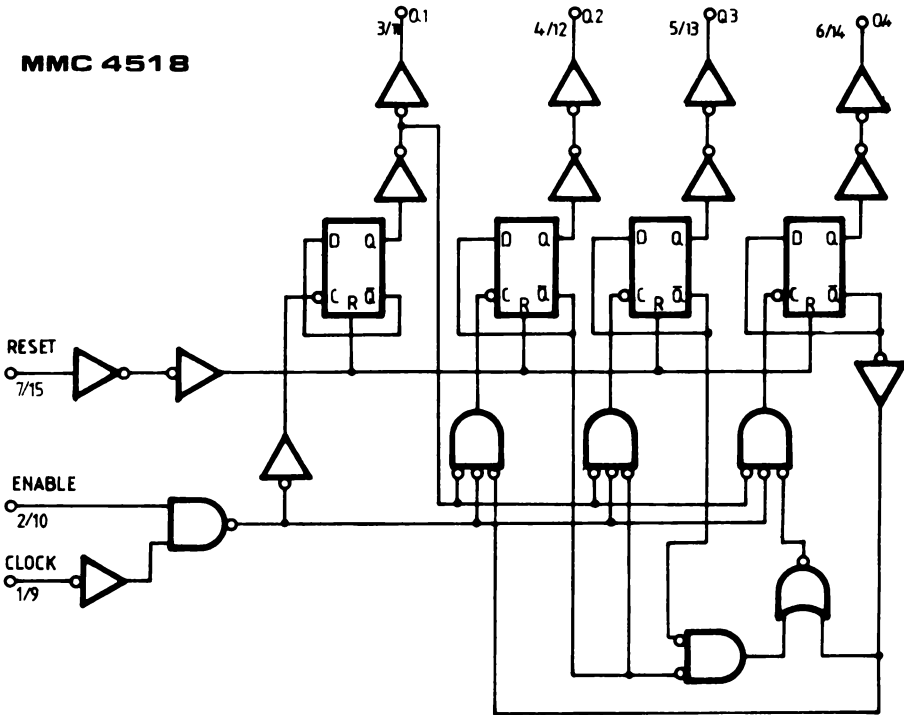

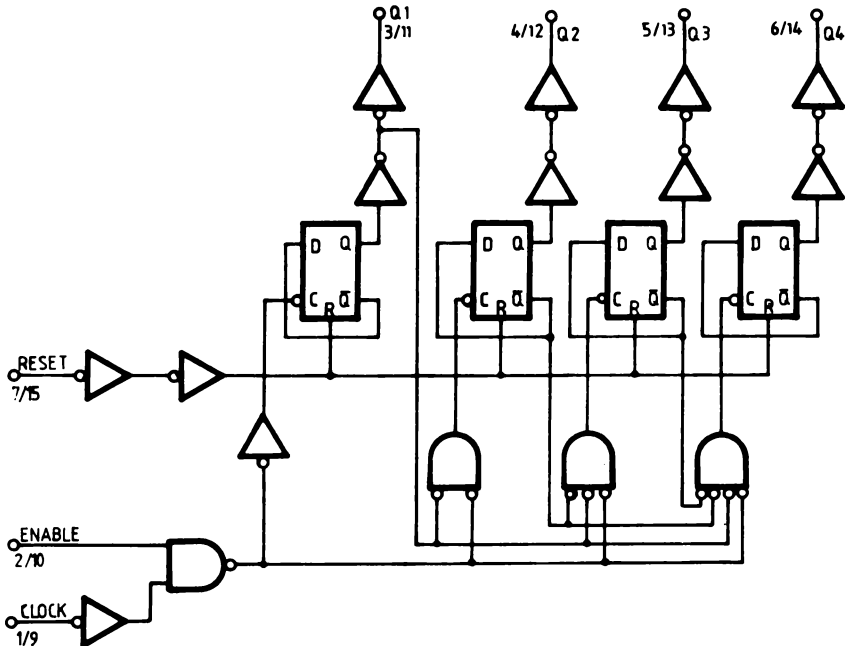

MMC 4518



MMC 4520



**TRUTH TABLE for MMC  
4518/4520**

| CLOCK   | ENABLE  | RESET | ACTION            |
|---|---|-------|-------------------|
|  | 1   | 1     | Increment counter |
| 0   |  | 0     | Inter counter     |
| X   |  | 0     | No change         |
|  | X   | 0     | No change         |
|  | 0   | 0     | No change         |
| 1   |  | 0     | No change         |
| X   | X   | 1     | Q1 thru Q4 = 0    |

**TIMING DIAGRAM**

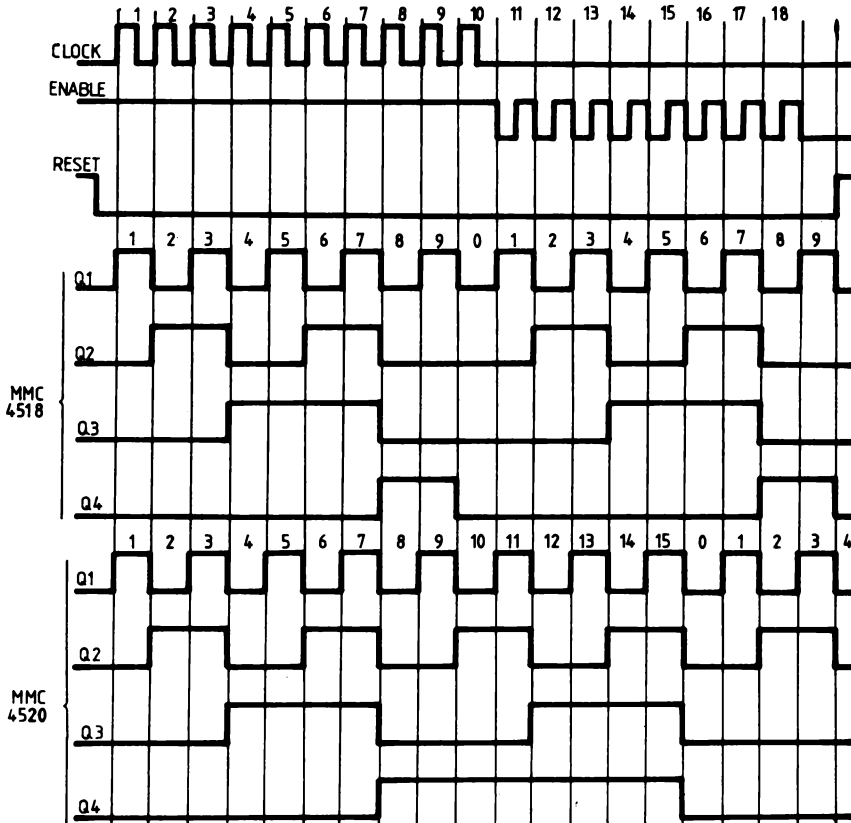

**STATIC ELECTRICAL CHARACTERISTICS**

(over recommended operating conditions)

| PARAMETER                         |                       |            | TEST CONDITIONS       |                       |                          |                        | VALUES             |       |                   |      |       |                     | UNIT |      |
|-----------------------------------|-----------------------|------------|-----------------------|-----------------------|--------------------------|------------------------|--------------------|-------|-------------------|------|-------|---------------------|------|------|
|                                   |                       |            | V <sub>I</sub><br>(V) | V <sub>O</sub><br>(V) | I <sub>O</sub>  <br>(μA) | V <sub>DD</sub><br>(V) | T <sub>LOW</sub> * |       | 25°C              |      |       | T <sub>HIGH</sub> * |      |      |
|                                   |                       |            |                       |                       |                          |                        | min.               | max.  | min.              | typ  | max.  | min.                |      | max. |
| I <sub>L</sub>                    | Quiescent current     | G, H types | 0/ 5                  |                       |                          | 5                      |                    | 5     |                   | 0.04 | 5     |                     | 150  |      |
|                                   |                       |            | 0/10                  |                       |                          | 10                     |                    | 10    |                   | 0.04 | 10    |                     | 300  |      |
|                                   |                       |            | 0/15                  |                       |                          | 15                     |                    | 20    |                   | 0.04 | 20    |                     | 600  |      |
|                                   |                       |            | 0/20                  |                       |                          | 20                     |                    | 100   |                   | 0.08 | 100   |                     | 3000 |      |
|                                   | E, F types            | 0/ 5       |                       |                       | 5                        |                        | 20                 |       | 0.04              | 20   |       | 150                 |      |      |
|                                   |                       | 0/10       |                       |                       | 10                       |                        | 40                 |       | 0.04              | 40   |       | 300                 |      |      |
| 0/15                              |                       |            |                       | 15                    |                          | 80                     |                    | 0.04  | 80                |      | 600   |                     |      |      |
| V <sub>OH</sub>                   | Output high voltage   | 0/ 5       |                       | < 1                   | 5                        | 4.95                   |                    | 4.95  |                   |      | 4.95  |                     | V    |      |
|                                   |                       | 0/10       |                       | < 1                   | 10                       | 9.95                   |                    | 9.95  |                   |      | 9.95  |                     |      |      |
|                                   |                       | 0/15       |                       | < 1                   | 15                       | 14.95                  |                    | 14.95 |                   |      | 14.95 |                     |      |      |
| V <sub>OL</sub>                   | Output low voltage    | 5 /0       |                       | < 1                   | 5                        |                        | 0.05               |       |                   | 0.05 |       | 0.05                | V    |      |
|                                   |                       | 10/0       |                       | < 1                   | 10                       |                        | 0.05               |       |                   | 0.05 |       | 0.05                |      |      |
|                                   |                       | 15/0       |                       | < 1                   | 15                       |                        | 0.05               |       |                   | 0.05 |       | 0.05                |      |      |
| V <sub>IH</sub>                   | Input high voltage    |            | 0.5/4.5               | < 1                   | 5                        | 3.5                    |                    | 3.5   |                   |      | 3.5   |                     | V    |      |
|                                   |                       |            | 1/9                   | < 1                   | 10                       | 7                      |                    | 7     |                   |      | 7     |                     |      |      |
|                                   |                       |            | 1.5/13.5              | < 1                   | 15                       | 11                     |                    | 11    |                   |      | 11    |                     |      |      |
| V <sub>IL</sub>                   | Input low voltage     |            | 4.5/0.5               | < 1                   | 5                        |                        | 1.5                |       |                   | 1.5  |       | 1.5                 | V    |      |
|                                   |                       |            | 9/1                   | < 1                   | 10                       |                        | 3                  |       |                   | 3    |       | 3                   |      |      |
|                                   |                       |            | 13.5/1.5              | < 1                   | 15                       |                        | 4                  |       |                   | 4    |       | 4                   |      |      |
| I <sub>OH</sub>                   | Output drive current  | G, H types | 0/ 5                  | 2.5                   |                          | 5                      | -2                 |       | -1.6              | -3.2 |       | -1.15               | mA   |      |
|                                   |                       |            | 0/ 5                  | 4.6                   |                          | 5                      | -0.64              |       | -0.51             | -1   |       | -0.36               |      |      |
|                                   |                       |            | 0/10                  | 9.5                   |                          | 10                     | -1.6               |       | -1.3              | -2.6 |       | -0.9                |      |      |
|                                   |                       |            | 0/15                  | 13.5                  |                          | 15                     | 4.2                |       | -3.4              | -6.8 |       | -2.4                |      |      |
|                                   |                       | E, F types | 0/ 5                  | 2.5                   |                          | 5                      | -1.53              |       | -1.36             | -3.2 |       | -1.1                |      |      |
|                                   |                       |            | 0/ 5                  | 4.6                   |                          | 5                      | 0.52               |       | -0.44             | 1    |       | 0.36                |      |      |
| 0/10                              | 9.5                   |            |                       | 10                    | -1.3                     |                        | 1.1                | -2.6  |                   | -0.9 |       |                     |      |      |
| 0/15                              | 13.5                  |            | 15                    | -3.6                  |                          | -3.0                   | -6.8               |       | 2.4               |      |       |                     |      |      |
| I <sub>OL</sub>                   | Output sink current   | G, H types | 0/ 5                  | 0.4                   |                          | 5                      | 0.64               |       | 0.51              | 1    |       | 0.36                | mA   |      |
|                                   |                       |            | 0/10                  | 0.5                   |                          | 10                     | 1.6                |       | 1.3               | 2.6  |       | 0.9                 |      |      |
|                                   |                       |            | 0/15                  | 1.5                   |                          | 15                     | 4.2                |       | 3.4               | 6.8  |       | 2.4                 |      |      |
|                                   |                       | E, F types | 0/ 5                  | 0.4                   |                          | 5                      | 0.52               |       | 0.44              | 1    |       | 0.36                |      |      |
|                                   |                       |            | 0/10                  | 0.5                   |                          | 10                     | 1.3                |       | 1.1               | 2.6  |       | 0.9                 |      |      |
|                                   |                       |            | 0/15                  | 1.5                   |                          | 15                     | 3.6                |       | 3.0               | 6.8  |       | 2.4                 |      |      |
| I <sub>IH</sub> , I <sub>IL</sub> | Input leakage current | G, H types | 0/18                  | Any input             | 18                       |                        | ±0.1               |       | ±10 <sup>-5</sup> | ±0.1 |       | ±1                  | μA   |      |
|                                   |                       | E, F types | 0/15                  |                       | 15                       |                        | ±0.3               |       | ±10 <sup>-5</sup> | ±0.3 |       | ±1                  |      |      |
| C <sub>I</sub>                    | Input capacitance     |            | Any input             |                       |                          |                        |                    |       | 5                 | 7.5  |       |                     | pF   |      |

\* T<sub>LOW</sub> = 55°C for G, H devices; -40°C for E, F devices.  
 \* T<sub>HIGH</sub> = +125°C for G, H devices; +85°C for E, F devices.  
 The Noise Margin for both "1" and "0" level is:

- 1 V min. with V<sub>DD</sub> = 5 V
- 2 V min. with V<sub>DD</sub> = 10 V
- 2.5 V min. with V<sub>DD</sub> = 15 V

**DYNAMIC ELECTRICAL CHARACTERISTICS**

( $T_A = 25^\circ\text{C}$ ,  $C_L = 50\text{ pF}$ ,  $R_L = 200\text{ k}$ , typical temperature coefficient for all  $V_{DD}$  values is  $0.3\%/^\circ\text{C}$ , all input rise and fall time =  $20\text{ ns}$ )

| PARAMETER   | TEST CONDITIONS<br>$V_{DD}(V)$ | VALUES |      |      | UNIT          |
|---|--------------------------------|--------|------|------|---------------|
|   |                                | Min.   | Typ. | Max. |               |
| $t_{PLH}$ , propagation delay time (Reset to output)<br>$t_{PHL}$           | 5                              |        | 280  | 560  | ns            |
|   | 10                             |        | 115  | 230  |               |
|   | 15                             |        | 80   | 160  |               |
| $t_{PLH}$ , Propagation delay time (Clock or Enable to output)<br>$t_{PHL}$ | 5                              |        | 330  | 650  | ns            |
|   | 10                             |        | 130  | 225  |               |
|   | 15                             |        | 90   | 170  |               |
| $t_{TLH}$ , Transition time<br>$t_{THL}$                                    | 5                              |        | 100  | 200  | ns            |
|   | 10                             |        | 50   | 100  |               |
|   | 15                             |        | 40   | 80   |               |
| $t_w$ , Clock pulse width   | 5                              | 200    | 100  |      | ns            |
|   | 10                             | 100    | 50   |      |               |
|   | 15                             | 70     | 35   |      |               |
| $t_w$ , Enable pulse width  | 5                              | 400    | 200  |      | ns            |
|   | 10                             | 200    | 100  |      |               |
|   | 15                             | 140    | 70   |      |               |
| $t_r$ , Clock or enable rise and fall time<br>$t_f$                         | 5                              |        |      | 15   | $\mu\text{s}$ |
|   | 10                             |        |      | 15   |               |
|   | 15                             |        |      | 5    |               |
| $f_{max}$ , Maximum clock frequency   | 5                              | 1.5    | 3    |      | MHz           |
|   | 10                             | 3      | 6    |      |               |
|   | 15                             | 4      | 8    |      |               |
| $t_r$ , Clock input rise and fall time<br>$t_f$                             | 5                              |        |      | 15   | $\mu\text{s}$ |
|   | 10                             |        |      | 5    |               |
|   | 15                             |        |      | 5    |               |
| $t_w$ , Reset pulse width   | 5                              | 250    | 125  |      | ns            |
|   | 10                             | 110    | 55   |      |               |
|   | 15                             | 80     | 40   |      |               |

**TYPICAL APPLICATIONS**

Ripple cascading of four counters with positive-edge triggering

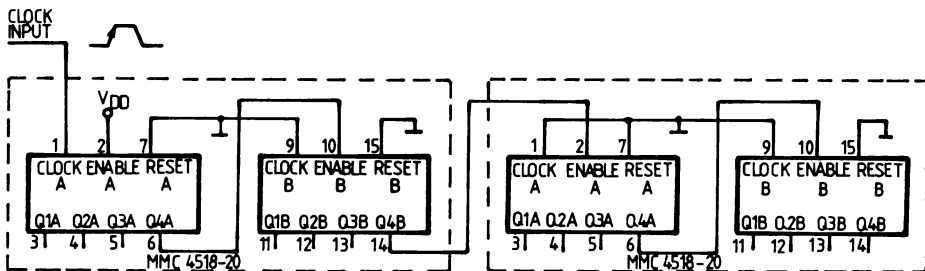

Synchronous cascading of four binary counters with negative-edge triggering

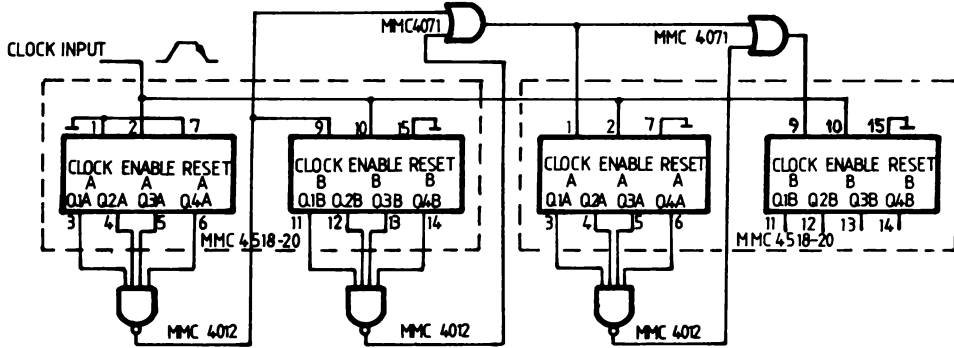

# BCD-TO-SEVEN SEGMENT LATCH/ DECODER/DRIVER

## GENERAL DESCRIPTION

The MMC 4543 BCD-to-7 Segment Latch/Decoder/Driver is designed for use with liquid crystal readouts and is constructed with complementary MOS (CMOS) enhancement-mode devices. The circuit provides the functions of a 4-bit storage latch and a B421 BCD-to-7 segment decoder and driver. The device has the capability to invert the logic levels of the output combinations. The Phase (Ph), Blanking (Bl), and Latch Disable (LD) inputs are used to reverse the truth-table phase, blank the display, and store a BCD code, respectively. For liquid crystal readouts, a square wave is applied to the Ph input of the circuit and the electrically common back plane of the display. The outputs of the circuit are connected directly to the segments of the readout. For other types of readouts, such as light-emitting diode (LED), incandescent, gas discharge, and fluorescent readouts, connections diagrams are given on this data sheet.

## FEATURES

- Phase input signal reproduced on outputs for liquid crystal display
- Latched storage of input code
- Blanking input for display intensity modulation
- Readout blanking for illegal input combinations
- Balanced output drive current specifications

## APPLICATIONS

Applications include instrument (e.g. counter, DVM, etc.) display driver, computer/calculator display driver, cockpit display driver, and various clock, watch, and timer uses.

## ABSOLUTE MAXIMUM RATINGS

|            |  |  |            |   |
|------------|--|--|------------|---|
| $V_{DD}^*$ | Supply voltage: G and H types<br>E and F types   | -0.5 to 20<br>-0.5 to 18<br>-0.5 to $V_{DD}+0.5$ |            | V<br>V<br>V                               |
| $V_i$      | Input voltage  |  |            | V   |
| $I_i$      | DC input current (any one input)   |  |            | $\pm 10$ mA                               |
| $P_{tot}$  | Total power dissipation (per package)<br>Dissipation per output transistor<br>for $T_A$ = full package-temperature range |  |            | 200 mW<br>100 mW                          |
| $T_A$      | Operating temperature : G and H types<br>E and F types   | -55 to -40 to -65 to                             | 125 85 150 | $^{\circ}C$<br>$^{\circ}C$<br>$^{\circ}C$ |
| $T_{stg}$  | Storage temperature  |  |            | $^{\circ}C$                               |

\* All voltage values are referred to  $V_{SS}$  pin voltage

## RECOMMENDED OPERATING CONDITIONS

|            |  |                |                |                            |
|------------|--|----------------|----------------|----------------------------|
| $V_{DD}^*$ | Supply voltage: G and H types<br>E and F types         | 3 to 3 to 0 to | 18 15 $V_{DD}$ | V<br>V<br>V                |
| $V_i$      | Input voltage  |                |                | V                          |
| $T_A$      | Operating temperature : G and H types<br>E and F types | -55 to -40 to  | 125 85         | $^{\circ}C$<br>$^{\circ}C$ |

## CONNECTION DIAGRAM

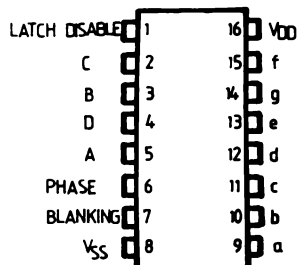

**STATIC ELECTRICAL CHARACTERISTICS**

(over recommended operating conditions)

| PARAMETER                       |                       | TEST CONDITIONS       |                       |                                |                        | VALUES           |       |           |       |                        |                   | UNIT  |         |         |
|---------------------------------|-----------------------|-----------------------|-----------------------|--------------------------------|------------------------|------------------|-------|-----------|-------|------------------------|-------------------|-------|---------|---------|
|                                 |                       | V <sub>I</sub><br>(V) | V <sub>O</sub><br>(V) | I <sub>O</sub>  <br>( $\mu$ A) | V <sub>DD</sub><br>(V) | T <sub>LOW</sub> |       | 25°C      |       |                        | T <sub>HIGH</sub> |       |         |         |
|                                 |                       |                       |                       |                                |                        | min.             | max.  | min.      | typ   | max.                   | min.              |       | max.    |         |
| I <sub>L</sub>                  | Quiescent current     | G, H types            | 0/ 5                  |                                |                        | 5                |       | 5         |       | 0.04                   | 5                 |       | 150     |         |
|                                 |                       |                       | 0/10                  |                                |                        | 10               |       | 10        |       | 0.04                   | 10                |       | 300     |         |
|                                 |                       |                       | 0/15                  |                                |                        | 15               |       | 20        |       | 0.04                   | 20                |       | 600     |         |
|                                 |                       |                       | 0/20                  |                                |                        | 20               |       | 100       |       | 0.08                   | 100               |       | 3000    |         |
|                                 |                       | E, F types            | 0/ 5                  |                                |                        | 5                |       | 20        |       | 0.04                   | 20                |       | 150     |         |
|                                 |                       |                       | 0/10                  |                                |                        | 10               |       | 40        |       | 0.04                   | 40                |       | 300     |         |
|                                 |                       |                       | 0/15                  |                                |                        | 15               |       | 80        |       | 0.04                   | 80                |       | 600     |         |
| V <sub>OH</sub>                 | Output high voltage   |                       | 0/ 5                  |                                | < 1                    | 5                | 4.95  |           | 4.95  |                        |                   | 4.95  |         | V       |
|                                 |                       |                       | 0/10                  |                                | < 1                    | 10               | 9.95  |           | 9.95  |                        |                   | 9.95  |         |         |
|                                 |                       |                       | 0/15                  |                                | < 1                    | 15               | 14.95 |           | 14.95 |                        |                   | 14.95 |         |         |
| V <sub>OL</sub>                 | Output low voltage    |                       | 5 / 0                 |                                | < 1                    | 5                |       | 0.05      |       |                        |                   | 0.05  |         | V       |
|                                 |                       |                       | 10/0                  |                                | < 1                    | 10               |       | 0.05      |       |                        |                   | 0.05  |         |         |
|                                 |                       |                       | 15/0                  |                                | < 1                    | 15               |       | 0.05      |       |                        |                   | 0.05  |         |         |
| V <sub>IH</sub>                 | Input high voltage    |                       |                       | 0.5/4.5                        | < 1                    | 5                | 3.5   |           | 3.5   |                        |                   | 3.5   |         | V       |
|                                 |                       |                       |                       | 1/9                            | < 1                    | 10               | 7     |           | 7     |                        |                   | 7     |         |         |
|                                 |                       |                       |                       | 1.5/13.5                       | < 1                    | 15               | 11    |           | 11    |                        |                   | 11    |         |         |
| V <sub>IL</sub>                 | Input low voltage     |                       |                       | 4.5/0.5                        | < 1                    | 5                |       | 1.5       |       |                        | 1.5               |       | 1.5     | V       |
|                                 |                       |                       |                       | 9/1                            | < 1                    | 10               |       | 3         |       |                        | 3                 |       | 3       |         |
|                                 |                       |                       |                       | 13.5/1.5                       | < 1                    | 15               |       | 4         |       |                        | 4                 |       | 4       |         |
| I <sub>OH</sub>                 | Output drive current  | G, H types            | 0/ 5                  | 2.5                            |                        | 5                | -2    |           | -1.6  | -3.2                   |                   | -1.15 |         | mA      |
|                                 |                       |                       | 0/ 5                  | 4.6                            |                        | 5                | -0.64 |           | -0.51 | -1                     |                   | -0.36 |         |         |
|                                 |                       |                       | 0/10                  | 9.5                            |                        | 10               | -1.6  |           | -1.3  | -2.6                   |                   | -0.9  |         |         |
|                                 |                       |                       | 0/15                  | 13.5                           |                        | 15               | -4.2  |           | -3.4  | -6.8                   |                   | -2.4  |         |         |
|                                 |                       | E, F types            | 0/ 5                  | 2.5                            |                        | 5                | -1.53 |           | -1.36 | -3.2                   |                   | -1.1  |         | mA      |
|                                 |                       |                       | 0/ 5                  | 4.6                            |                        | 5                | -0.52 |           | -0.44 | -1                     |                   | -0.36 |         |         |
|                                 |                       |                       | 0/10                  | 9.5                            |                        | 10               | -1.3  |           | -1.1  | -2.6                   |                   | -0.9  |         |         |
|                                 |                       |                       | 0/15                  | 13.5                           |                        | 15               | -3.6  |           | -3.0  | -6.8                   |                   | -2.4  |         |         |
| I <sub>OL</sub>                 | Output sink current   | G, H types            | 0/ 5                  | 0.4                            |                        | 5                | 0.64  |           | 0.51  | 1                      |                   | 0.36  |         | mA      |
|                                 |                       |                       | 0/10                  | 0.5                            |                        | 10               | 1.6   |           | 1.3   | 2.6                    |                   | 0.9   |         |         |
|                                 |                       |                       | 0/15                  | 1.5                            |                        | 15               | 4.2   |           | 3.4   | 6.8                    |                   | 2.4   |         |         |
|                                 |                       | E, F types            | 0/ 5                  | 0.4                            |                        | 5                | 0.52  |           | 0.44  | 1                      |                   | 0.36  |         | mA      |
|                                 |                       |                       | 0/10                  | 0.5                            |                        | 10               | 1.3   |           | 1.1   | 2.6                    |                   | 0.9   |         |         |
|                                 |                       |                       | 0/15                  | 1.5                            |                        | 15               | 3.6   |           | 3.0   | 6.8                    |                   | 2.4   |         |         |
| I <sub>IH</sub> I <sub>IL</sub> | Input leakage current | G, H types            | 0/18                  | Any input                      |                        | 18               |       | $\pm$ 0.1 |       | $\pm$ 10 <sup>-5</sup> | $\pm$ 0.1         |       | $\pm$ 1 | $\mu$ A |
|                                 |                       | E, F types            | 0/15                  |                                |                        | 15               |       | $\pm$ 0.3 |       | $\pm$ 10 <sup>-5</sup> | $\pm$ 0.3         |       | $\pm$ 1 |         |
| C <sub>I</sub>                  | Input capacitance     |                       |                       | Any input                      |                        |                  |       |           |       | 5                      | 7.5               |       |         | pF      |

\* T<sub>LOW</sub> = -55°C for G, H devices; -40°C for E, F devices.

\* T<sub>HIGH</sub> = +125°C for G, H devices; +85°C for E, F devices.

The Noise Margin for both "1" and "0" level is:

1 V min. with V<sub>DD</sub> = 5 V

2 V min. with V<sub>DD</sub> = 10 V

2.5 V min. with V<sub>DD</sub> = 15 V

**DYNAMIC ELECTRICAL CHARACTERISTICS**

(C<sub>L</sub> = 5 pF, T<sub>A</sub> = 25°C)

| PARAMETER  | V <sub>DD</sub><br>(Vdc) | VALUES |                   |                    | UNIT |
|--|--------------------------|--------|-------------------|--------------------|------|
|  |                          | min.   | typ.              | max.               |      |
| t <sub>PHL</sub> , t <sub>PLH</sub> Propagation delay time     | 5<br>10<br>15            |        | 550<br>210<br>160 | 1100<br>420<br>320 | ns   |
| t <sub>TLH</sub> , t <sub>THL</sub> Output transition time     | 5<br>10<br>15            |        | 100<br>50<br>40   | 200<br>100<br>80   | ns   |
| t <sub>s</sub> , t <sub>up</sub> Minimum data input setup time | 5<br>10<br>15            |        | -40<br>-15<br>-10 | 0<br>0<br>0        | ns   |
| t <sub>hold</sub> Minimum data input hold time                 | 5<br>10<br>15            |        | 40<br>15<br>10    | 80<br>30<br>20     | ns   |
| PW <sub>LD</sub> Minimum LD pulse width                        | 5<br>10<br>15            |        | 125<br>50<br>40   | 250<br>100<br>80   | ns   |

**TRUTH TABLE**

| INPUTS |    |     |   |   |   |   | OUTPUTS                              |   |   |   |   |   |   | Display          |
|--------|----|-----|---|---|---|---|--------------------------------------|---|---|---|---|---|---|------------------|
| LD     | BI | Ph* | D | C | B | A | a                                    | b | c | d | e | f | g |                  |
| X      | 1  | 0   | X | X | X | X | 0                                    | 0 | 0 | 0 | 0 | 0 | 0 | Blank            |
| 1      | 0  | 0   | 0 | 0 | 0 | 0 | 1                                    | 1 | 1 | 1 | 1 | 1 | 0 | 0                |
| 1      | 0  | 0   | 0 | 0 | 0 | 1 | 0                                    | 1 | 1 | 0 | 0 | 0 | 0 | 1                |
| 1      | 0  | 0   | 0 | 0 | 1 | 0 | 1                                    | 1 | 0 | 1 | 1 | 0 | 1 | 2                |
| 1      | 0  | 0   | 0 | 0 | 1 | 1 | 1                                    | 1 | 1 | 1 | 0 | 0 | 1 | 3                |
| 1      | 0  | 0   | 0 | 1 | 0 | 0 | 0                                    | 1 | 1 | 0 | 0 | 1 | 1 | 4                |
| 1      | 0  | 0   | 0 | 1 | 0 | 1 | 1                                    | 0 | 1 | 1 | 0 | 1 | 1 | 5                |
| 1      | 0  | 0   | 0 | 1 | 1 | 0 | 1                                    | 0 | 1 | 1 | 1 | 1 | 1 | 6                |
| 1      | 0  | 0   | 0 | 1 | 1 | 1 | 1                                    | 1 | 1 | 0 | 0 | 0 | 0 | 7                |
| 1      | 0  | 0   | 1 | 0 | 0 | 0 | 1                                    | 1 | 1 | 1 | 1 | 1 | 1 | 8                |
| 1      | 0  | 0   | 1 | 0 | 0 | 1 | 1                                    | 1 | 1 | 1 | 0 | 1 | 1 | 9                |
| 1      | 0  | 0   | 1 | 0 | 1 | 0 | 0                                    | 0 | 0 | 0 | 0 | 0 | 0 | Blank            |
| 1      | 0  | 0   | 1 | 0 | 1 | 1 | 0                                    | 0 | 0 | 0 | 0 | 0 | 0 | Blank            |
| 1      | 0  | 0   | 1 | 1 | 0 | 0 | 0                                    | 0 | 0 | 0 | 0 | 0 | 0 | *Blank           |
| 1      | 0  | 0   | 1 | 1 | 0 | 1 | 0                                    | 0 | 0 | 0 | 0 | 0 | 0 | Blank            |
| 1      | 0  | 0   | 1 | 1 | 1 | 0 | 0                                    | 0 | 0 | 0 | 0 | 0 | 0 | Blank            |
| 1      | 0  | 0   | 1 | 1 | 1 | 1 | 0                                    | 0 | 0 | 0 | 0 | 0 | 0 | Blank            |
| 0      | 0  | 0   | X | X | X | X |                                      | * | * |   |   |   |   | * *              |
| †      | †  | 1   |   | † |   |   | Inverse of output combinations above |   |   |   |   |   |   | Display as above |

X = Don't care

† = Above combinations

\* = For liquid crystal readouts, apply a square wave to Ph

For common cathode LED readouts, select Ph = 0

For common anode LED readouts, select Ph = 1

\*\* = Depends upon the BCD code previously applied when LD = 1



LOGIC DIAGRAM

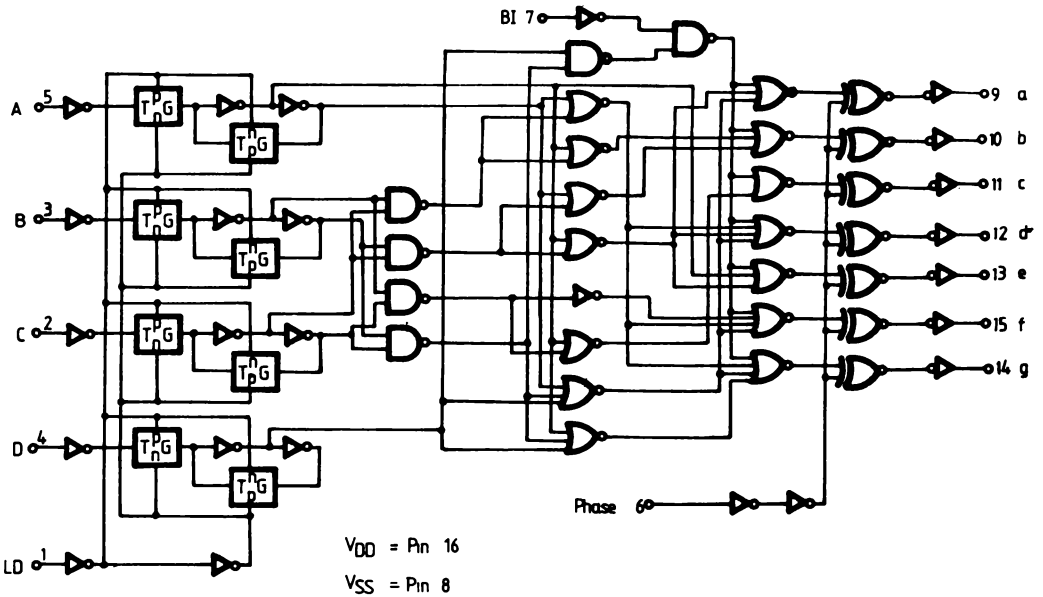

TYPICAL APPLICATIONS

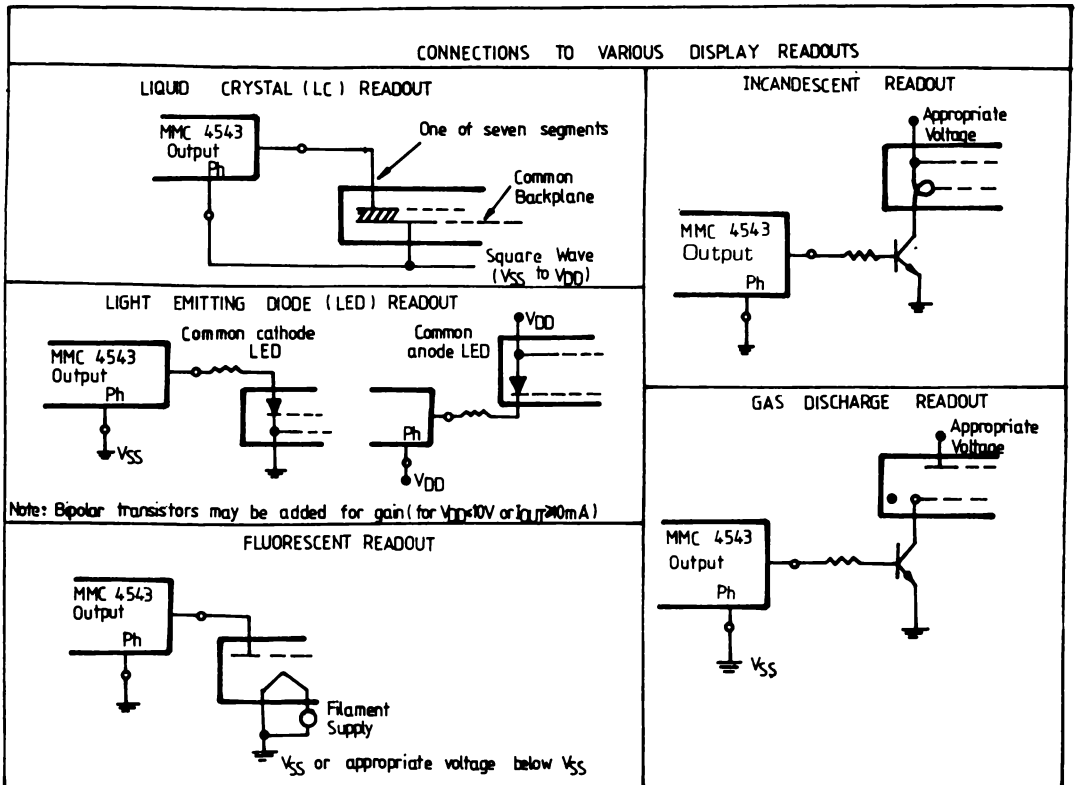

# 4-BIT BIDIRECTIONAL UNIVERSAL SHIFT REGISTER

## GENERAL DESCRIPTION

The MMC 40104 is a monolithic i.c., available in 16-lead dual in-line plastic or ceramic package. The MMC 40104 is a universal shift register featuring parallel inputs, parallel outputs, SHIFT RIGHT and SHIFT LEFT serial inputs, and a high-impedance third output state allowing the device to be used in bus-organized systems. In the parallel-load mode (S0 and S1 are high), data is loaded into the associated flip-flop and appears at the output after the positive transition of the CLOCK input. During loading, serial data flow is inhibited. Shift-right and shift-left are accomplished synchronously on the positive clock edge with serial data entered at the SHIFT RIGHT and SHIFT LEFT serial inputs, respectively. Clearing the register is accomplished by setting both mode controls low and clocking the register. When the output enable input is low, all outputs assume the high impedance state.

## FEATURES

- Medium-speed operation:  $f_{CL} = 9$  MHz,  $V_{DD} = 10$  V
- Fully static operation
- Synchronous parallel or serial operation
- Three-state outputs

## APPLICATIONS

Control circuitry

## ABSOLUTE MAXIMUM RATINGS

|            |  |  |  |
|------------|--|--|--|
| $V_{DD}^*$ | Supply voltage: G and H types<br>E and F types   | -0.5 to 20<br>-0.5 to 18<br>-0.5 to $V_{DD}+0.5$ | V<br>V<br>V                                  |
| $V_i$      | Input voltage  |  | $V_{DD}+0.5$                                 |
| $I_i$      | DC input current (any one input)   |  | $\pm 10$ mA                                  |
| $P_{tot}$  | Total power dissipation (per package)<br>Dissipation per output transistor<br>for $T_A =$ full package-temperature range |  | 200 mW<br>100 mW                             |
| $T_A$      | Operating temperature :  | -55 to 125<br>-40 to 85<br>-65 to 150            | $^{\circ}$ C<br>$^{\circ}$ C<br>$^{\circ}$ C |
| $T_{stg}$  | Storage temperature  |  |  |

\* All voltage values are referred to  $V_{SS}$  pin voltage

## RECOMMENDED OPERATING CONDITIONS

|            |  |                         |                              |
|------------|--|-------------------------|------------------------------|
| $V_{DD}^*$ | Supply voltage: G and H types<br>E and F types | 3 to 18<br>3 to 15      | V<br>V                       |
| $V_i$      | Input voltage                                  | 0 to $V_{DD}$           | V                            |
| $T_A$      | Operating temperature :                        | -55 to 125<br>-40 to 85 | $^{\circ}$ C<br>$^{\circ}$ C |

## CONNECTION DIAGRAM

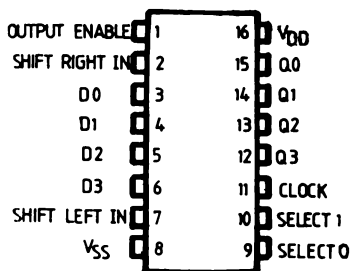

TOP VIEW

LOGIC DIAGRAM

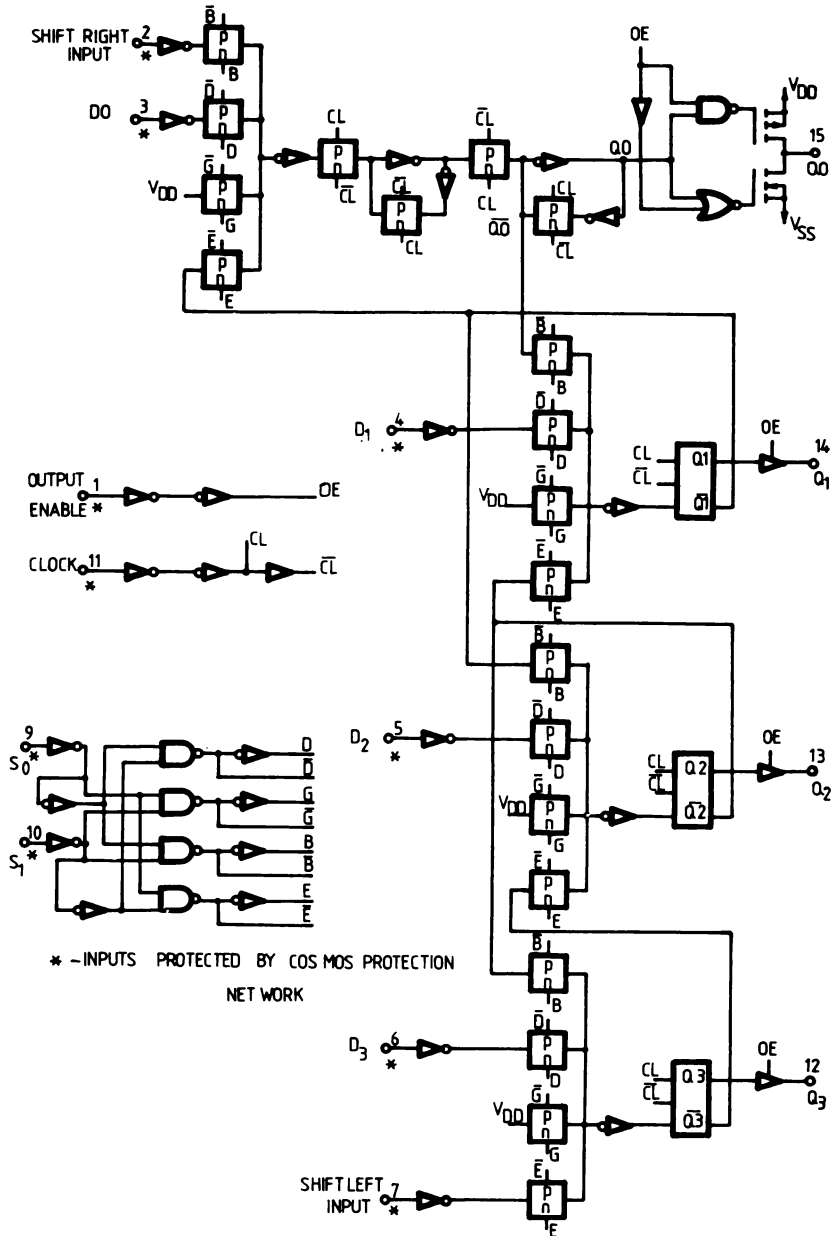

**STATIC ELECTRICAL CHARACTERISTICS**

(over recommended operating conditions)

| PARAMETER                       |                       |            | TEST CONDITIONS       |                            |                                |                        | VALUES                |                      |                       |                      |                       |                      | UNIT    |      |
|---------------------------------|-----------------------|------------|-----------------------|----------------------------|--------------------------------|------------------------|-----------------------|----------------------|-----------------------|----------------------|-----------------------|----------------------|---------|------|
|                                 |                       |            | V <sub>I</sub><br>(V) | V <sub>O</sub><br>(V)      | I <sub>O</sub>  <br>( $\mu$ A) | V <sub>DD</sub><br>(V) | T <sub>LOW</sub>      |                      | 25°C                  |                      |                       | T <sub>HIGH</sub>    |         |      |
|                                 |                       |            |                       |                            |                                |                        | min.                  | max.                 | min.                  | typ                  | max.                  | min.                 |         | max. |
| I <sub>L</sub>                  | Quiescent current     | G, H types | 0/ 5                  |                            |                                | 5                      |                       | 5                    |                       | 0.04                 | 5                     |                      | 150     |      |
|                                 |                       |            | 0/10                  |                            |                                | 10                     |                       | 10                   |                       | 0.04                 | 10                    |                      | 300     |      |
|                                 |                       |            | 0/15                  |                            |                                | 15                     |                       | 20                   |                       | 0.04                 | 20                    |                      | 600     |      |
|                                 |                       |            | 0/20                  |                            |                                | 20                     |                       | 100                  |                       | 0.08                 | 100                   |                      | 3000    |      |
|                                 |                       | E, F types | 0/ 5                  |                            |                                | 5                      |                       | 20                   |                       | 0.04                 | 20                    |                      | 150     |      |
|                                 |                       |            | 0/10                  |                            |                                | 10                     |                       | 40                   |                       | 0.04                 | 40                    |                      | 300     |      |
|                                 |                       | 0/15       |                       |                            | 15                             |                        | 80                    |                      | 0.04                  | 80                   |                       | 600                  |         |      |
| V <sub>OH</sub>                 | Output high voltage   |            | 0/ 5<br>0/10<br>0/15  |                            | < 1<br>< 1<br>< 1              | 5<br>10<br>15          | 4.95<br>9.95<br>14.95 |                      | 4.95<br>9.95<br>14.95 |                      | 4.95<br>9.95<br>14.95 |                      | V       |      |
| V <sub>OL</sub>                 | Output low voltage    |            | 5 /0<br>10/0<br>15/0  |                            | < 1<br>< 1<br>< 1              | 5<br>10<br>15          |                       | 0.05<br>0.05<br>0.05 |                       | 0.05<br>0.05<br>0.05 |                       | 0.05<br>0.05<br>0.05 | V       |      |
| V <sub>IH</sub>                 | Input high voltage    |            |                       | 0.5/4.5<br>1/9<br>1.5/13.5 | < 1<br>< 1<br>< 1              | 5<br>10<br>15          | 3.5<br>7<br>11        |                      | 3.5<br>7<br>11        |                      | 3.5<br>7<br>11        |                      | V       |      |
| V <sub>IL</sub>                 | Input low voltage     |            |                       | 4.5/0.5<br>9/1<br>13.5/1.5 | < 1<br>< 1<br>< 1              | 5<br>10<br>15          |                       | 1.5<br>3<br>4        |                       | 1.5<br>3<br>4        |                       | 1.5<br>3<br>4        | V       |      |
| I <sub>OH</sub>                 | Output drive current  | G, H types | 0/ 5                  | 2.5                        |                                | 5                      | -2                    |                      | -1.6                  | -3.2                 |                       | -1.15                |         |      |
|                                 |                       |            | 0/ 5                  | 4.6                        |                                | 5                      | -0.64                 |                      | -0.51                 | -1                   |                       | -0.36                |         |      |
|                                 |                       |            | 0/10                  | 9.5                        |                                | 10                     | -1.6                  |                      | -1.3                  | -2.6                 |                       | -0.9                 |         |      |
|                                 |                       |            | 0/15                  | 13.5                       |                                | 15                     | -4.2                  |                      | -3.4                  | -6.8                 |                       | -2.4                 |         |      |
|                                 |                       | E, F types | 0/ 5                  | 2.5                        |                                | 5                      | -1.53                 |                      | -1.36                 | -3.2                 |                       | -1.1                 |         |      |
|                                 |                       |            | 0/ 5                  | 4.6                        |                                | 5                      | -0.52                 |                      | -0.44                 | -1                   |                       | -0.36                |         |      |
|                                 |                       | 0/10       | 9.5                   |                            | 10                             | -1.3                   |                       | -1.1                 | -2.6                  |                      | -0.9                  |                      |         |      |
|                                 |                       | 0/15       | 13.5                  |                            | 15                             | -3.6                   |                       | -3.0                 | -6.8                  |                      | -2.4                  |                      |         |      |
| I <sub>OL</sub>                 | Output sink current   | G, H types | 0/ 5                  | 0.4                        |                                | 5                      | 0.64                  |                      | 0.51                  | 1                    |                       | 0.36                 |         |      |
|                                 |                       |            | 0/10                  | 0.5                        |                                | 10                     | 1.6                   |                      | 1.3                   | 2.6                  |                       | 0.9                  |         |      |
|                                 |                       |            | 0/15                  | 1.5                        |                                | 15                     | 4.2                   |                      | 3.4                   | 6.8                  |                       | 2.4                  |         |      |
|                                 |                       | E, F types | 0/ 5                  | 0.4                        |                                | 5                      | 0.52                  |                      | 0.44                  | 1                    |                       | 0.36                 |         |      |
|                                 |                       |            | 0/10                  | 0.5                        |                                | 10                     | 1.3                   |                      | 1.1                   | 2.6                  |                       | 0.9                  |         |      |
|                                 |                       |            | 0/15                  | 1.5                        |                                | 15                     | 3.6                   |                      | 3.0                   | 6.8                  |                       | 2.4                  |         |      |
| I <sub>IH</sub> I <sub>IL</sub> | Input leakage current | G, H types | 0/18                  | Any input                  |                                | 18                     |                       | $\pm 0.1$            |                       | $\pm 10^{-5}$        | $\pm 0.1$             |                      | $\pm 1$ |      |
|                                 |                       | E, F types | 0/15                  |                            |                                | 15                     |                       | $\pm 0.3$            |                       | $\pm 10^{-5}$        | $\pm 0.3$             |                      | $\pm 1$ |      |
| C <sub>I</sub>                  | Input capacitance     |            |                       | Any input                  |                                |                        |                       |                      |                       | 5                    | 7.5                   |                      | pF      |      |

\* T<sub>LOW</sub> = -55°C for G, H devices; -40°C for E, F devices.

\* T<sub>HIGH</sub> = +125°C for G, H devices; +85°C for E, F devices.

The Noise Margin for both "1" and "0" level is:

1 V min. with V<sub>DD</sub> = 5 V

2 V min. with V<sub>DD</sub> = 10 V





2.5 V min. with V<sub>DD</sub> = 15 V

**DYNAMIC ELECTRICAL CHARACTERISTICS**

( $T_A = 25^\circ\text{C}$ ,  $C_L = 50\text{ pF}$ ,  $R_L = 200\text{ kohm}$ , typical temperature coefficient for all  $V_{DD}$  values is  $0.3\%/^\circ\text{C}$ , all input rise and fall time =  $20\text{ ns}$ ).

| PARAMETER          |                                      | TEST CONDITIONS    | VALUES |      |      | UNIT          |
|--------------------|--------------------------------------|--------------------|--------|------|------|---------------|
|                    |                                      | $V_{DD}(\text{V})$ | min.   | typ. | max. |               |
| $t_{PLH}$          | Propagation delay time<br>Clock to Q | 5                  |        | 220  | 440  | ns            |
| $t_{PHL}$          |                                      | 10                 |        | 100  | 200  |               |
|                    |                                      | 15                 |        | 70   | 140  |               |
| $t_{PZH}$          | 3—state outputs<br>High impedance    | 5                  |        | 80   | 160  | ns            |
| $t_{PZL}$          |                                      | 10                 |        | 35   | 70   |               |
| $t_{PZ}$           |                                      | 15                 |        | 25   | 50   |               |
| $t_{PHZ}$          |                                      | 5                  |        | 45   | 90   | ns            |
|                    |                                      | 10                 |        | 25   | 50   |               |
|                    |                                      | 15                 |        | 20   | 40   |               |
| $t_{THL}$          | Transition time                      | 5                  |        | 100  | 200  | ns            |
| $t_{TLH}$          |                                      | 10                 |        | 50   | 100  |               |
|                    |                                      | 15                 |        | 40   | 80   |               |
| $t_{\text{setup}}$ | Setup time D0, D3, SR, SL to Clock   | 5                  |        | 80   | 100  | ns            |
|                    |                                      | 10                 |        | 35   | 70   |               |
|                    |                                      | 15                 |        | 20   | 50   |               |
|                    | S0, S1 to Clock                      | 5                  |        | 200  | 400  | ns            |
|                    |                                      | 10                 |        | 110  | 220  |               |
|                    |                                      | 15                 |        | 65   | 130  |               |
| $t_{\text{hold}}$  | Hold time D0, D3, SR, SL             | 5                  |        | -65  | 0    | ns            |
|                    |                                      | 10                 |        | -25  | 0    |               |
|                    |                                      | 15                 |        | -15  | 0    |               |
|                    | S0, S1 to Clock                      | 5                  |        | -170 | 0    | ns            |
|                    |                                      | 10                 |        | -95  | 0    |               |
|                    |                                      | 15                 |        | -55  | 0    |               |
| $t_w$              | Clock pulse width                    | 5                  |        | 90   | 180  | ns            |
|                    |                                      | 10                 |        | 40   | 180  |               |
|                    |                                      | 15                 |        | 25   | 50   |               |
| $f_{CL}$           | Clock input frequency                | 5                  | 3      | 6    |      | MHz           |
|                    |                                      | 10                 | 6      | 12   |      |               |
|                    |                                      | 15                 | 8      | 15   |      |               |
| $t_r, t_f$         | Clock input rise or fall time        | 5                  |        |      | 1000 | $\mu\text{s}$ |
|                    |                                      | 10                 |        |      | 100  |               |
|                    |                                      | 15                 |        |      | 100  |               |

**TRUTH TABLE**

| CLOCK   | MODE SELECT |    | OUTPUT ENABLE | ACTION   |
|---|-------------|----|---------------|--|
|   | S0          | S1 |               |  |
|  | 0           | 0  | 1             | Reset  |
|  | 1           | 0  | 1             | Shift right (Q0 toward Q3)   |
|  | 0           | 1  | 1             | Shift left (Q3 toward Q0)  |
|  | 1           | 1  | 1             | Parallel load  |
| x   | x           | x  | 0             | Operations occur as shown above, but outputs assume high impedance |

# DUAL 2-INPUT NAND BUFFER/DRIVER

## GENERAL DESCRIPTION

The MMC 40107 is a monolithic i.c., available in 14-lead dual in-line ceramic package and plastic package.

The MMC 40107 is a dual 2-input NAND buffer/driver containing two independent 2-input NAND buffers with open-drain single n-channel transistor outputs

This device features a wired-OR capability and high output sink current capability (136 mA typ at  $V_{DD} = 10\text{ V}$ ,  $V_{DS} = 1\text{ V}$ )

## FEATURES

- quiescent current specified to 20 V
- maximum input leakage of 1  $\mu\text{A}$  at 18 V (full package temperature range)
- standardized symmetrical output characteristics
- 5 V, 10 V, and 15 V parametric ratings

## APPLICATIONS

Driver circuits

## ABSOLUTE MAXIMUM RATINGS

|            |  |  |                         |  |
|------------|--|--|-------------------------|--|
| $V_{DD}^*$ | Supply voltage: G and H types<br>E and F types   | -0.5 to 20<br>-0.5 to 18<br>-0.5 to 18 | 20<br>18<br>18          | V<br>V<br>V                              |
| $V_i$      | Input voltage  | -0.5 to $V_{DD}+0.5$                   |                         | V  |
| $I_i$      | DC input current (any one input)   |  | $\pm 10$                | mA                                       |
| $P_{tot}$  | Total power dissipation (per package)<br>Dissipation per output transistor<br>for $T_A =$ full package-temperature range |  | 200                     | mW                                       |
| $T_A$      | Operating temperature :  | G and H types<br>E and F types         | -55 to 125<br>-40 to 85 | $^{\circ}\text{C}$<br>$^{\circ}\text{C}$ |
| $T_{stg}$  | Storage temperature  |  | -65 to 150              | $^{\circ}\text{C}$                       |

\* All voltage values are referred to  $V_{SS}$  pin voltage

## RECOMMENDED OPERATING CONDITIONS

|            |  |                                     |                         |  |
|------------|--|-------------------------------------|-------------------------|--|
| $V_{DD}^*$ | Supply voltage: G and H types<br>E and F types | 3 to 18<br>3 to 15<br>0 to $V_{DD}$ | 18<br>15<br>$V_{DD}$    | V<br>V<br>V                              |
| $V_i$      | Input voltage                                  |                                     |                         |  |
| $T_A$      | Operating temperature :                        | G and H types<br>E and F types      | -55 to 125<br>-40 to 85 | $^{\circ}\text{C}$<br>$^{\circ}\text{C}$ |

## CONNECTION DIAGRAM

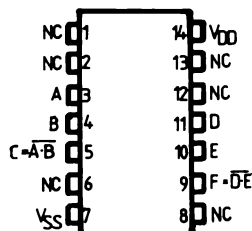

**STATIC ELECTRICAL CHARACTERISTICS**

(over recommended operating conditions)

| PARAMETER  |            | TEST CONDITIONS            |                            |                                |                        | VALUES             |               |                |                  |               |                     | UNIT    |      |
|--|------------|----------------------------|----------------------------|--------------------------------|------------------------|--------------------|---------------|----------------|------------------|---------------|---------------------|---------|------|
|  |            | V <sub>I</sub><br>(V)      | V <sub>O</sub><br>(V)      | I <sub>O</sub>  <br>( $\mu$ A) | V <sub>DD</sub><br>(V) | T <sub>LOW</sub> * |               | 25°C           |                  |               | T <sub>HIGH</sub> * |         |      |
|  |            |                            |                            |                                |                        | min.               | max.          | min.           | typ              | max.          | min.                |         | max. |
| I <sub>L</sub> Quiescent current                                     | G, H types | 0/ 5                       |                            |                                | 5                      |                    | 1             |                | 0.02             | 1             |                     | 30      |      |
|  |            | 0/10                       |                            |                                | 10                     |                    | 2             |                | 0.02             | 2             |                     | 60      |      |
|  |            | 0/15                       |                            |                                | 15                     |                    | 4             |                | 0.02             | 4             |                     | 120     |      |
|  |            | 0/20                       |                            |                                | 20                     |                    | 20            |                | 0.04             | 20            |                     | 600     |      |
|  | E, F types | 0/ 5                       |                            |                                | 5                      |                    | 4             |                | 0.02             | 4             |                     | 30      |      |
|  |            | 0/10                       |                            |                                | 10                     |                    | 8             |                | 0.02             | 8             |                     | 60      |      |
| 0/15   |            |                            |                            | 15                             |                        | 16                 |               | 0.02           | 16               |               | 120                 |         |      |
| V <sub>IH</sub> ** Input high voltage                                |            |                            | 0.5/4.5<br>1/9<br>1.5/13.5 | < 1<br>< 1<br>< 1              | 5<br>10<br>15          | 3.5<br>7<br>11     |               | 3.5<br>7<br>11 |                  |               | 3.5<br>7<br>11      | V       |      |
| V <sub>IL</sub> ** Input low voltage                                 |            |                            | 4.5<br>9<br>13.5           | < 1<br>< 1<br>< 1              | 5<br>10<br>15          |                    | 1.5<br>3<br>4 |                |                  | 1.5<br>3<br>4 | 1.5<br>3<br>4       | V       |      |
| I <sub>OL</sub> Output sink current                                  | G, H types | 5                          | 0.4                        |                                | 5                      | 21                 |               | 16             | 32               |               | 12                  |         |      |
|  |            | 5                          | 1                          |                                | 5                      | 44                 |               | 30             | 68               |               | 25                  |         |      |
|  |            | 10                         | 0.5                        |                                | 10                     | 49                 |               | 37             | 74               |               | 28                  |         |      |
|  |            | 10                         | 1                          |                                | 10                     | 89                 |               | 68             | 136              |               | 51                  |         |      |
|  |            | 15                         | 0.5                        |                                | 15                     | 66                 |               | 50             | 100              |               | 38                  |         |      |
|  | E, F types | 5                          | 0.4                        |                                | 5                      | 17                 |               | 13.6           | 32               |               | 12                  |         |      |
|  |            | 5                          | 1                          |                                | 5                      | 35.7               |               | 25.5           | 68               |               | 22                  |         |      |
|  |            | 10                         | 0.5                        |                                | 10                     | 39.1               |               | 31.4           | 74               |               | 27                  |         |      |
|  |            | 10                         | 1                          |                                | 10                     | 72.2               |               | 57.8           | 136              |               | 51                  |         |      |
|  |            | 15                         | 0.5                        |                                | 15                     | 53.5               |               | 42.5           | 100              |               | 37                  |         |      |
| I <sub>OH</sub> Output drive current                                 |            | No internal pull-up device |                            |                                |                        |                    |               |                |                  |               |                     | mA      |      |
| I <sub>IH</sub> , I <sub>IL</sub> Input leakage current              | G, H types | 0/18                       | Any input                  |                                | 18                     |                    | $\pm 0.1$     |                | $\pm 10^{-5}$    | $\pm 0.1$     |                     | $\pm 1$ |      |
|  | E, F types | 0/15                       |                            |                                | 15                     |                    | $\pm 0.3$     |                | $\pm 10^{-5}$    | $\pm 0.3$     |                     | $\pm 1$ |      |
| I <sub>OH</sub> , I <sub>OL</sub> *** 3-state output leakage current | G, H types | 0/18                       | 18                         |                                | 18                     |                    | 2             |                | 10 <sup>-4</sup> | 2             |                     | 20      |      |
|  | E, F types | 0/15                       | 15                         |                                | 15                     |                    | 2             |                | 10 <sup>-4</sup> | 2             |                     | 20      |      |
| C <sub>I</sub> Input capacitance                                     | Any input  |                            |                            |                                |                        |                    |               | 5              | 7.5              |               |                     | pF      |      |
| C <sub>O</sub> Output capacitance                                    | Any output |                            |                            |                                |                        |                    |               | 30             |                  |               |                     |         |      |

\* T<sub>LOW</sub> = -55°C for G, H devices; -40°C for E, F devices.

\* T<sub>HIGH</sub> = +125°C for G, H devices; +85°C for E, F devices.

The Noise Margin for both "1" and "0" level is:

1 V min. with V<sub>DD</sub> = 5 V

2 V min. with V<sub>DD</sub> = 10 V

2.5 V min. with V<sub>DD</sub> = 15 V

\*\* Measured with external pull-up resistor, R<sub>L</sub> = 10 K $\Omega$  to V<sub>DD</sub>

\*\*\* Forced output disabled

**DYNAMIC ELECTRICAL CHARACTERISTICS**

( $T_A = 25^\circ\text{C}$ ,  $C_L = 50\text{ pF}$ , typical temperature coefficient for all  $V_{DD}$  values is  $0.3\%/^\circ\text{C}$ , all input rise and fall time = 20 ns)

| PARAMETER  | TEST CONDITIONS       | VALUES             |      |      | UNIT |      |
|--|-----------------------|--------------------|------|------|------|------|
|  |                       | $V_{DD}(\text{V})$ | min. | typ. |      | max. |
| $t_{PHL}$<br>Propagation delay time<br>High-to-Low | $R_L^* = 120\ \Omega$ | 5                  |      | 100  | 200  | ns   |
|  |                       | 10                 |      | 45   | 90   |      |
|  |                       | 15                 |      | 30   | 60   |      |
| Low-to-High  | $R_L^* = 120\ \Omega$ | 5                  |      | 100  | 200  | ns   |
|  |                       | 10                 |      | 60   | 120  |      |
|  |                       | 15                 |      | 50   | 100  |      |
| $t_{THL}$<br>Transition time<br>High-to-Low        | $R_L^* = 120\ \Omega$ | 5                  |      | 50   | 100  | ns   |
|  |                       | 10                 |      | 20   | 40   |      |
|  |                       | 15                 |      | 10   | 20   |      |
| Low-to-High  | $R_L^* = 120\ \Omega$ | 5                  |      | 50   | 100  | ns   |
|  |                       | 10                 |      | 35   | 70   |      |
|  |                       | 15                 |      | 25   | 50   |      |

\* $R_L$  is external pull-up resistor to  $V_{DD}$ .

**SCHEMATIC DIAGRAM AND TRUTH TABLE**

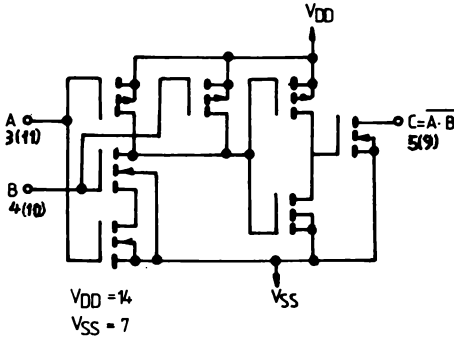

TRUTH TABLE

| A | B | C  |
|---|---|----|
| 0 | 0 | 1* |
| 1 | 0 | 1* |
| 0 | 1 | 1* |
| 1 | 1 | 0  |

\* Requires external pull-up resistor ( $R_L$ ) to  $V_{DD}$ .

\* Without pull-up resistor (3-state)

**TYPICAL APPLICATIONS**

The bar on the output line of this logic diagram indicates that the output is open drain as is shown in the previous schematic diagram and truth table.

Line-driver circuit

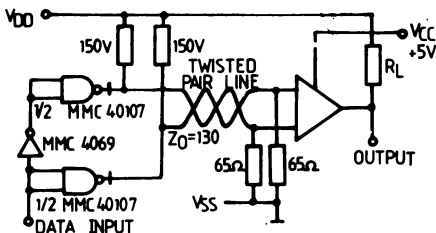

Direct dc drive interface of 40107 with a triac

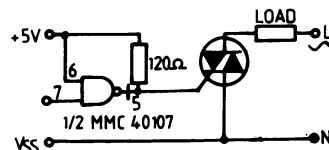



Motor-controller circuit

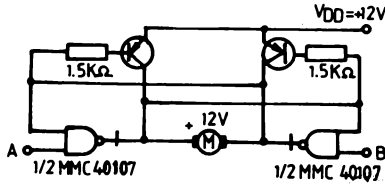

Interface of 40107 with triac, with COS/MOS component and triac isolated

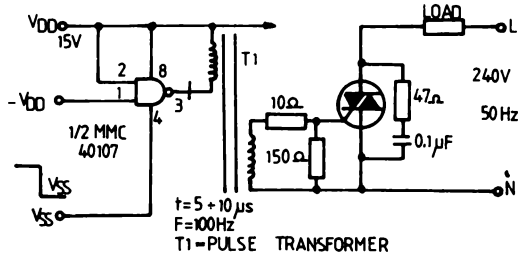

LED driver circuit

| A | B | MOTOR FUNCTION    |
|---|---|-------------------|
| 0 | 0 | OFF               |
| 1 | 0 | COUNTER CLOCKWISE |
| 1 | 1 | AS PREVIOUS STATE |
| 0 | 1 | CLOCKWISE         |
| 1 | 1 | AS PREVIOUS STATE |

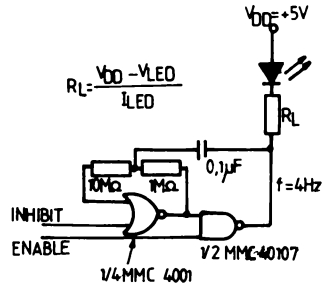

A 2.2 watt incandescent lamp-driver circuit

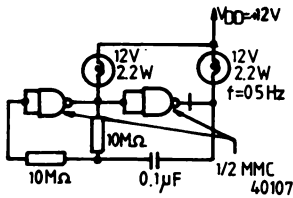

| INHIBIT | ENABLE | OUTPUT |
|---------|--------|--------|
| 0       | 0      | OFF    |
| 1       | 0      | OFF    |
| 0       | 1      | OFF    |
| 1       | 1      | ON     |

Multiplexed LED circuit

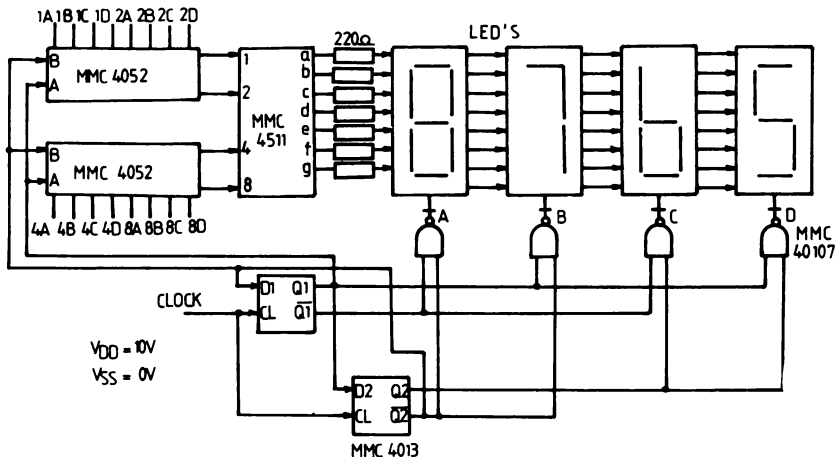

# 4-BIT ARITHMETIC LOGIC UNIT

## GENERAL DESCRIPTION

The MMC 40181 is a monolithic integrated circuit, available in 24-lead dual in-line plastic or ceramic package.

The MMC 40181 is a low-power four-bit parallel arithmetic logic unit (ALU) capable of providing 16 binary arithmetic operations on two Boolean variables. The mode control input M selects logical (M = High) or arithmetical (M = Low) operation. The four select inputs (S0, S1, S2 and S3) select the desired logical or arithmetical functions, which include AND, OR, NAND, NOR and exclusive-OR and-NOR in the logical mode, and addition, subtraction, decrement, left-shift, and straight transfer in the arithmetic mode, according to the truth table. The MMC 40181 operation may be interpreted with either active-low or active-high data at the A and B word inputs and the function outputs F, by using the appropriate truth table. The MMC 40181 contains logic for full look-ahead carry operation for fast carry generation using the carry-generate and carry-propagate out-

puts  $\bar{G}$  and  $\bar{P}$  for the four bits of the MMC 40181. A ripple carry output  $C_{n+4}$  is available for use in systems where speed is not of primary importance. Also included in the MMC 40181 is a comparator output  $A = B$ , which assumes a high level whenever the four-bit input words A and B are equal and the device is in the subtract mode. In addition, relative magnitude information may be derived from the carry-in input  $C_n$  and ripple carry-out output  $C_{n-4}$  by placing the unit in the subtract mode and externally decoding using the information in Table II.

## FEATURES

- Full look-ahead carry for speed operations on long words
- Generates 16 logic functions of two boolean variables
- Generates 16 arithmetic functions of two 4-bit binary words
- $A = B$  comparator output available

## ABSOLUTE MAXIMUM RATINGS

|            |  |  |                           |
|------------|--|--|---------------------------|
| $V_{DD}^*$ | Supply voltage: G and H types<br>E and F types   | -0.5 to 20<br>-0.5 to 18<br>-0.5 to $V_{DD}+0.5$ | V<br>V<br>V               |
| $V_i$      | Input voltage  |  | $V_{DD}+0.5$ V            |
| $I_i$      | DC input current (any one input)   |  | $\pm 10$ mA               |
| $P_{tot}$  | Total power dissipation (per package)<br>Dissipation per output transistor<br>for $T_A$ = full package-temperature range |  | 200 mW<br>100 mW          |
| $T_A$      | Operating temperature : G and H types<br>E and F types   | -55 to -40 to -65 to                             | 125 85 150 °C<br>°C<br>°C |
| $T_{stg}$  | Storage temperature  |  | 150 °C                    |

\* All voltage values are referred to  $V_{SS}$  pin voltage

## RECOMMENDED OPERATING CONDITIONS

|            |  |                |                            |
|------------|--|----------------|----------------------------|
| $V_{DD}^*$ | Supply voltage: G and H types<br>E and F types         | 3 to 3 to 0 to | 18 15 $V_{DD}$ V<br>V<br>V |
| $V_i$      | Input voltage  |                | $V_{DD}$ V                 |
| $T_A$      | Operating temperature : G and H types<br>E and F types | -55 to -40 to  | 125 85 °C<br>°C            |

## CONNECTION DIAGRAM

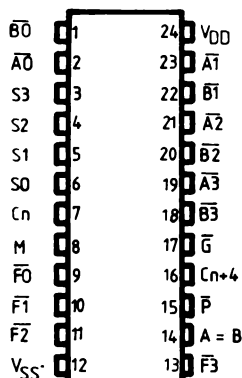

**STATIC ELECTRICAL CHARACTERISTICS**

(over recommended operating conditions)

| PARAMETER                         |                       | TEST CONDITIONS       |                       |                                |                        | VALUES             |           |       |               |           |                     | UNIT    |         |  |
|-----------------------------------|-----------------------|-----------------------|-----------------------|--------------------------------|------------------------|--------------------|-----------|-------|---------------|-----------|---------------------|---------|---------|--|
|                                   |                       | V <sub>I</sub><br>(V) | V <sub>O</sub><br>(V) | I <sub>O</sub>  <br>( $\mu$ A) | V <sub>DD</sub><br>(V) | T <sub>LOW</sub> * |           | 25°C  |               |           | T <sub>HIGH</sub> * |         |         |  |
|                                   |                       |                       |                       |                                |                        | min.               | max.      | min.  | typ           | max.      | min.                |         | max.    |  |
| I <sub>L</sub>                    | Quiescent current     | G, H types            | 0/ 5                  |                                |                        | 5                  |           | 5     |               | 0.04      | 5                   |         | 150     |  |
|                                   |                       |                       | 0/10                  |                                |                        | 10                 |           | 10    |               | 0.04      | 10                  |         | 300     |  |
|                                   |                       |                       | 0/15                  |                                |                        | 15                 |           | 20    |               | 0.04      | 20                  |         | 600     |  |
|                                   |                       |                       | 0/20                  |                                |                        | 20                 |           | 100   |               | 0.08      | 100                 |         | 3000    |  |
|                                   | E, F types            | 0/ 5                  |                       |                                | 5                      |                    | 20        |       | 0.04          | 20        |                     | 150     |         |  |
|                                   |                       | 0/10                  |                       |                                | 10                     |                    | 40        |       | 0.04          | 40        |                     | 300     |         |  |
|                                   |                       | 0/15                  |                       |                                | 15                     |                    | 80        |       | 0.04          | 80        |                     | 600     |         |  |
| V <sub>OH</sub>                   | Output high voltage   | 0/ 5                  |                       | < 1                            | 5                      | 4.95               |           | 4.95  |               |           | 4.95                |         | V       |  |
|                                   |                       | 0/10                  |                       | < 1                            | 10                     | 9.95               |           | 9.95  |               |           | 9.95                |         |         |  |
|                                   |                       | 0/15                  |                       | < 1                            | 15                     | 14.95              |           | 14.95 |               |           | 14.95               |         |         |  |
| V <sub>OL</sub>                   | Output low voltage    | 5 /0                  |                       | < 1                            | 5                      |                    | 0.05      |       |               | 0.05      |                     | 0.05    | V       |  |
|                                   |                       | 10/0                  |                       | < 1                            | 10                     |                    | 0.05      |       |               | 0.05      |                     | 0.05    |         |  |
|                                   |                       | 15/0                  |                       | < 1                            | 15                     |                    | 0.05      |       |               | 0.05      |                     | 0.05    |         |  |
| V <sub>IH</sub>                   | Input high voltage    |                       | 0.5/4.5               | < 1                            | 5                      | 3.5                |           | 3.5   |               |           | 3.5                 |         | V       |  |
|                                   |                       |                       | 1/9                   | < 1                            | 10                     | 7                  |           | 7     |               |           | 7                   |         |         |  |
|                                   |                       |                       | 1.5/13.5              | < 1                            | 15                     | 11                 |           | 11    |               |           | 11                  |         |         |  |
| V <sub>IL</sub>                   | Input low voltage     |                       | 4.5/0.5               | < 1                            | 5                      |                    | 1.5       |       |               | 1.5       |                     | 1.5     | V       |  |
|                                   |                       |                       | 9/1                   | < 1                            | 10                     |                    | 3         |       |               | 3         |                     | 3       |         |  |
|                                   |                       |                       | 13.5/1.5              | < 1                            | 15                     |                    | 4         |       |               | 4         |                     | 4       |         |  |
| I <sub>OH</sub>                   | Output drive current  | G, H types            | 0/ 5                  | 2.5                            |                        | 5                  | -2        |       | -1.6          | -3.2      |                     | -1.15   | mA      |  |
|                                   |                       |                       | 0/ 5                  | 4.6                            |                        | 5                  | -0.64     |       | -0.51         | -1        |                     | -0.36   |         |  |
|                                   |                       |                       | 0/10                  | 9.5                            |                        | 10                 | -1.6      |       | -1.3          | -2.6      |                     | -0.9    |         |  |
|                                   |                       |                       | 0/15                  | 13.5                           |                        | 15                 | -4.2      |       | -3.4          | -6.8      |                     | -2.4    |         |  |
|                                   |                       | E, F types            | 0/ 5                  | 2.5                            |                        | 5                  | -1.53     |       | -1.36         | -3.2      |                     | -1.1    |         |  |
|                                   |                       |                       | 0/ 5                  | 4.6                            |                        | 5                  | -0.52     |       | -0.44         | -1        |                     | -0.36   |         |  |
|                                   |                       | 0/10                  | 9.5                   |                                | 10                     | -1.3               |           | -1.1  | -2.6          |           | -0.9                |         |         |  |
|                                   |                       | 0/15                  | 13.5                  |                                | 15                     | -3.6               |           | -3.0  | -6.8          |           | -2.4                |         |         |  |
| I <sub>OL</sub>                   | Output sink current   | G, H types            | 0/ 5                  | 0.4                            |                        | 5                  | 0.64      |       | 0.51          | 1         |                     | 0.36    | mA      |  |
|                                   |                       |                       | 0/10                  | 0.5                            |                        | 10                 | 1.6       |       | 1.3           | 2.6       |                     | 0.9     |         |  |
|                                   |                       |                       | 0/15                  | 1.5                            |                        | 15                 | 4.2       |       | 3.4           | 6.8       |                     | 2.4     |         |  |
|                                   |                       | E, F types            | 0/ 5                  | 0.4                            |                        | 5                  | 0.52      |       | 0.44          | 1         |                     | 0.36    |         |  |
|                                   |                       |                       | 0/10                  | 0.5                            |                        | 10                 | 1.3       |       | 1.1           | 2.6       |                     | 0.9     |         |  |
|                                   |                       |                       | 0/15                  | 1.5                            |                        | 15                 | 3.6       |       | 3.0           | 6.8       |                     | 2.4     |         |  |
| I <sub>IH</sub> , I <sub>IL</sub> | Input leakage current | G, H types            | 0/18                  | Any input                      | 18                     |                    | $\pm 0.1$ |       | $\pm 10^{-5}$ | $\pm 0.1$ |                     | $\pm 1$ | $\mu$ A |  |
|                                   |                       | E, F types            | 0/15                  |                                | 15                     |                    | $\pm 0.3$ |       | $\pm 10^{-5}$ | $\pm 0.3$ |                     | $\pm 1$ |         |  |
| C <sub>I</sub>                    | Input capacitance     |                       | Any input             |                                |                        |                    |           |       | 5             | 7.5       |                     |         | pF      |  |

\* T<sub>LOW</sub> = -55°C for G, H devices; -40°C for E, F devices.

\* T<sub>HIGH</sub> = +125°C for G, H devices; +85°C for E, F devices.

The Noise Margin for both "1" and "0" level is:

1 V min. with V<sub>DD</sub> = 5 V

2 V min. with V<sub>DD</sub> = 10 V

2.5 V min. with V<sub>DD</sub> = 15 V

**DYNAMIC ELECTRICAL CHARACTERISTICS**

( $T_A = 25^\circ\text{C}$ ,  $C_L = 50\text{ pF}$ ,  $R_L = 200\text{ k}\Omega$ , typical temperature coefficient for all  $V_{DD} = 0.3\%/^\circ\text{C}$  all input rise and fall times = 20 ns).

| PARAMETER          | TEST CONDITIONS                        | VALUES       |      |      | UNIT |      |
|--------------------|--|--------------|------|------|------|------|
|                    |  | $V_{DD}$ (V) | min. | typ. |      | max. |
| $t_{PLH}$          | Propagation delay time                 | 5            |      | 400  | 800  | ns   |
| $t_{PHL}$          | A or B to F (logic mode)               | 10           |      | 160  | 320  |      |
|                    | A or B to G or P                       | 15           |      | 120  | 240  |      |
|                    | A or B to F,<br>$C_{n+4}$ , or $A = B$ | 5            |      | 300  | 1000 | ns   |
|                    |  | 10           |      | 200  | 400  |      |
|                    |  | 15           |      | 140  | 280  |      |
| $C_n$ to F         |  | 5            |      | 320  | 640  | ns   |
|                    |  | 10           |      | 135  | 270  |      |
|                    |  | 15           |      | 100  | 200  |      |
| $C_n$ to $C_{n+4}$ |  | 5            |      | 200  | 400  | ns   |
|                    |  | 10           |      | 100  | 200  |      |
|                    |  | 15           |      | 70   | 140  |      |
| $t_{TLH}$          | Transition time                        | 5            |      | 100  | 200  | ns   |
| $t_{THL}$          |  | 10           |      | 50   | 100  |      |
|                    |  | 15           |      | 40   | 80   |      |

**FUNCTIONAL DIAGRAM**

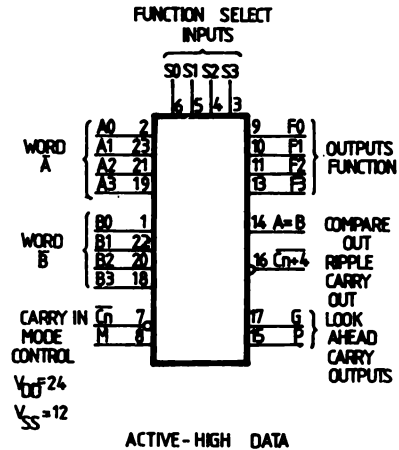
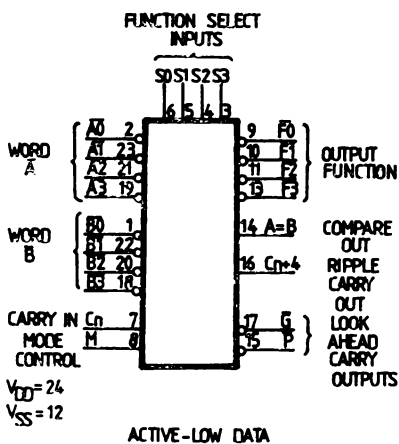

LOGIC DIAGRAM

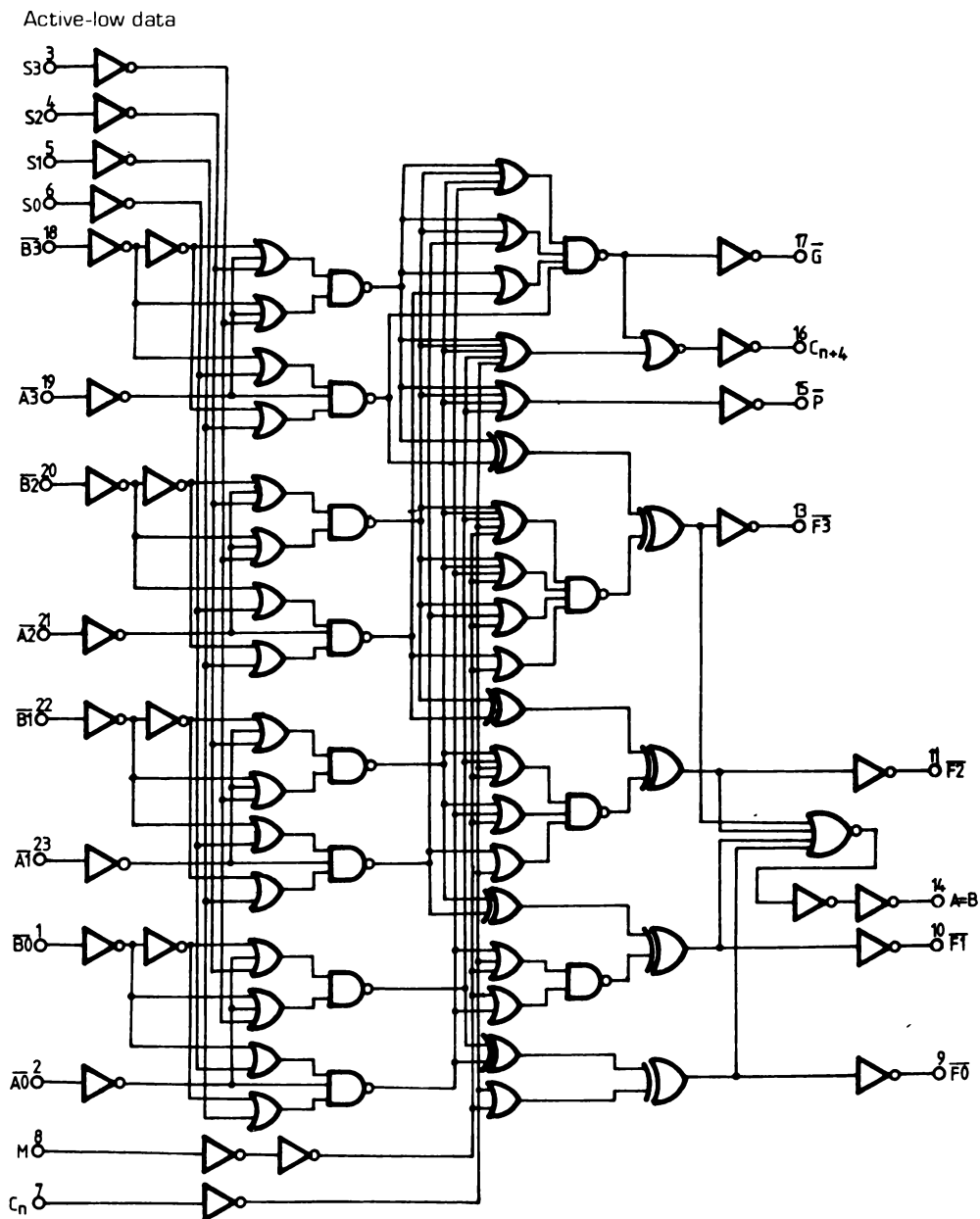

**TRUTH TABLES** Table I

| FUNCTION SELECT |    |    |    | INPUTS/OUTPUTS ACTIVE LOW |   | INPUTS/OUTPUTS ACTIVE HIGH |   |
|-----------------|----|----|----|---------------------------|---|----------------------------|---|
|                 |    |    |    | LOGIC FUNCTION (M=H)      | ARITHMETIC* FUNCTION (M=L, C <sub>n</sub> =L) | LOGIC FUNCTION (M=H)       | ARITHMETIC* FUNCTION (M=L, C <sub>n</sub> =H) |
| S3              | S2 | S1 | S0 |                           |   |                            |   |
| 0               | 0  | 0  | 0  | $\bar{A}$                 | A minus 1                                     | $\bar{A}$                  | A   |
| 0               | 0  | 0  | 1  | $\bar{A}\bar{B}$          | AB minus 1                                    | $\overline{A+B}$           | A + B   |
| 0               | 0  | 1  | 0  | $\bar{A} + B$             | $\bar{A}\bar{B}$ minus 1                      | $\bar{A}\bar{B}$           | A + $\bar{B}$                                 |
| 0               | 0  | 1  | 1  | Logic 1                   | minus 1                                       | Logic 0                    | minus 1                                       |
| 0               | 1  | 0  | 0  | $\bar{A} + \bar{B}$       | A plus (A + $\bar{B}$ )                       | $\bar{A}\bar{B}$           | A plus $\bar{A}\bar{B}$                       |
| 0               | 1  | 0  | 1  | $\bar{B}$                 | AB plus (A + $\bar{B}$ )                      | $\bar{B}$                  | (A + B) plus $\bar{A}\bar{B}$                 |
| 0               | 1  | 1  | 0  | $\overline{A \oplus B}$   | A minus B minus 1                             | $A \oplus B$               | A minus B minus 1                             |
| 0               | 1  | 1  | 1  | $A + \bar{B}$             | A + $\bar{B}$                                 | $\bar{A}\bar{B}$           | $\bar{A}\bar{B}$ minus 1                      |
| 1               | 0  | 0  | 0  | $\bar{A}\bar{B}$          | A plus (A + B)                                | $\bar{A} + B$              | A plus AB                                     |
| 1               | 0  | 0  | 1  | $A \oplus B$              | A plus B                                      | $\overline{A \oplus B}$    | A plus B                                      |
| 1               | 0  | 1  | 0  | B                         | $\bar{A}\bar{B}$ plus (A + B)                 | B                          | (A + $\bar{B}$ ) plus AB                      |
| 1               | 0  | 1  | 1  | A + B                     | A + B   | AB                         | AB minus 1                                    |
| 1               | 1  | 0  | 0  | Logic 0                   | A plus A                                      | Logic 1                    | A plus A                                      |
| 1               | 1  | 0  | 1  | $\bar{A}\bar{B}$          | $\bar{A}\bar{B}$ plus A                       | $A + \bar{B}$              | (A + B) plus A                                |
| 1               | 1  | 1  | 0  | AB                        | $\bar{A}\bar{B}$ plus A                       | A + B                      | (A + $\bar{B}$ ) plus A                       |
| 1               | 1  | 1  | 1  | A                         | A   | A                          | A minus 1                                     |

\* Expressed as two's complement. For arithmetic function with C<sub>n</sub> in opposite state, the resulting function is as shown plus 1.

Table II — **MAGNITUDE COMPARISON**

**Active-High data**

| INPUT C <sub>n</sub> | OUTPUT C <sub>n+4</sub> | MAGNITUDE |
|----------------------|-------------------------|-----------|
| 1                    | 1                       | A ≤ B     |
| 0                    | 1                       | A < B     |
| 1                    | 0                       | A > B     |
| 0                    | 0                       | A ≥ B     |

**Active-Low data**

| INPUT C <sub>n</sub> | OUTPUT C <sub>n+4</sub> | MAGNITUDE |
|----------------------|-------------------------|-----------|
| 0                    | 0                       | A ≤ B     |
| 1                    | 0                       | A < B     |
| 0                    | 1                       | A > B     |
| 1                    | 1                       | A ≥ B     |

1 = HIGH LEVEL  
0 = LOW LEVEL

Table III — **AC TEST SETUP REFERENCE (active-low data)**

| TEST DELAY TIMES  |                                    | AC PATHS         |                  | DC DATA INPUTS                         |                                | MODE*        |
|-------------------|------------------------------------|------------------|------------------|--|--------------------------------|--------------|
|                   |                                    | INPUTS           | OUTPUTS          | TO V <sub>SS</sub>                     | TO V <sub>DD</sub>             |              |
| SUM <sub>IN</sub> | to SUM <sub>OUT</sub>              | $\bar{B}0$       | Any $\bar{F}$    | $\bar{B}1, \bar{B}2, \bar{B}3, M, C_n$ | All $\bar{A}$ 's               | ADD          |
| SUM <sub>IN</sub> | to P                               | $\bar{A}0$       | $\bar{P}$        | $\bar{A}1, \bar{A}2, \bar{A}3, M, C_n$ | All $\bar{B}$ 's               | ADD          |
| SUM <sub>IN</sub> | to G                               | $\bar{B}0$       | $\bar{G}$        | All $\bar{A}$ 's, M, C <sub>n</sub>    | $\bar{B}1, \bar{B}2, \bar{B}3$ | ADD          |
| SUM <sub>IN</sub> | to C <sub>n+4</sub>                | $\bar{B}0$       | C <sub>n+4</sub> | All $\bar{A}$ 's, M, C <sub>n</sub>    | $\bar{B}1, \bar{B}2, \bar{B}3$ | ADD          |
| C <sub>n</sub>    | to SUM <sub>OUT</sub>              | C <sub>n</sub>   | Any $\bar{F}$    | All $\bar{A}$ 's, M                    | All $\bar{B}$ 's               | ADD          |
| C <sub>n</sub>    | to C <sub>n+4</sub>                | C <sub>n</sub>   | C <sub>n+4</sub> | All $\bar{A}$ 's, M                    | All $\bar{B}$ 's               | ADD          |
| SUM <sub>IN</sub> | to A=B                             | $\bar{B}0$       | A=B              | All As, B1, B2, B3, M                  | C <sub>n</sub>                 | SUBSTRACT    |
| SUM <sub>IN</sub> | to SUM <sub>OUT</sub> (Logic Mode) | All $\bar{B}$ 's | Any $\bar{F}$    | All A's, C <sub>n</sub>                | M                              | EXCLUSIVE OR |

\* ADD Mode: S0, S3 = V<sub>DD</sub>; S1, S2 = V<sub>SS</sub>.

SUBSTRACT Mode: S0, S3 = V<sub>SS</sub>; S1, S2 = V<sub>DD</sub>.

# PRESETTABLE UP/DOWN COUNTERS (DUAL CLOCK WITH RESET)

## 40192-BCD TYPE 40193-BINARY TYPE

### GENERAL DESCRIPTION

The MMC 40192, MMC 40193 are monolithic integrated circuits processed in standard Al-gate technology. The MMC 40192 is a 4-Bit Synchronous Up/Down Decade Counter and the MMC 40193 is a 4-Bit Synchronous Up/Down Binary Counter. Counting up and counting down is performed by two count inputs (CLOCK UP and CLOCK DOWN respectively), one being held high while the other is clocked. The outputs ( $Q_1$ — $Q_4$ ) change on the positive-going transition of this clock. These counters feature preset inputs ( $J_1$ — $J_4$ ) that are enabled when load (PRESET ENABLE) is a logical „0“ and a clear (RESET) which forces all outputs to „0“ when it is at logical „1“. The counters also have CARRY and BORROW inputs so that they can be cascaded using no external circuitry.

### FEATURES

- Individual clock lines for counting up or counting down
- Synchronous high-speed carry and borrow propagation delays for cascading
- Active low parallel load
- Active high asynchronous reset
- Quiescent current specified at 20 V
- 5 V, 10 V, 15 V parametric ratings

### ABSOLUTE MAXIMUM RATINGS

|            |  |                    |              |          |
|------------|--|--------------------|--------------|----------|
| $V_{DD}^*$ | Supply voltage: G and H types<br>E and F types   | -0.5 to<br>-0.5 to | 20<br>18     | V<br>V   |
| $V_i$      | Input voltage  | -0.5 to            | $V_{DD}+0.5$ | V        |
| $I_i$      | DC input current (any one input)   |                    | $\pm 10$     | mA       |
| $P_{tot}$  | Total power dissipation (per package)<br>Dissipation per output transistor<br>for $T_A$ = full package-temperature range |                    | 200          | mW       |
| $T_A$      | Operating temperature : G and H types<br>E and F types   | -55 to<br>-40 to   | 125<br>85    | °C<br>°C |
| $T_{stg}$  | Storage temperature  | -65 to             | 150          | °C       |

\* All voltage values are referred to  $V_{SS}$  pin voltage

### RECOMMENDED OPERATING CONDITIONS

|            |  |                  |           |          |
|------------|--|------------------|-----------|----------|
| $V_{DD}^*$ | Supply voltage: G and H types<br>E and F types         | 3 to<br>3 to     | 18<br>15  | V<br>V   |
| $V_i$      | Input voltage  | 0 to             | $V_{DD}$  | V        |
| $T_A$      | Operating temperature : G and H types<br>E and F types | -55 to<br>-40 to | 125<br>85 | °C<br>°C |

### CONNECTION DIAGRAM

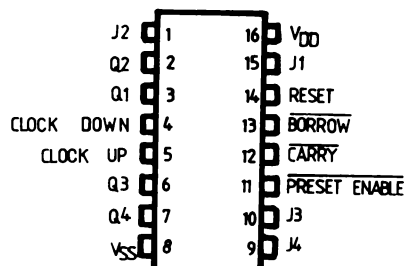

LOGIC DIAGRAM

MMC 40192

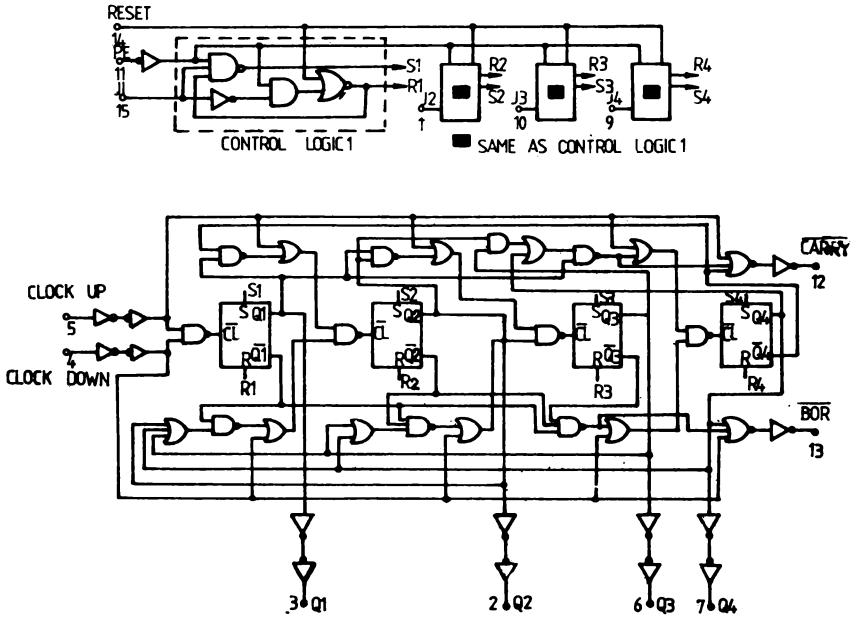

MMC 40193

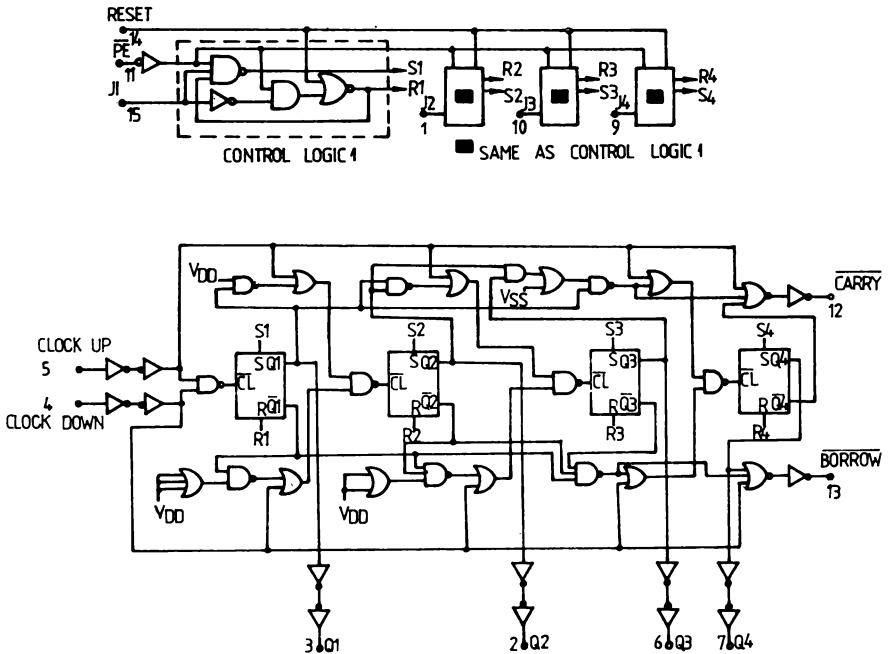



**TIMING DIAGRAM**

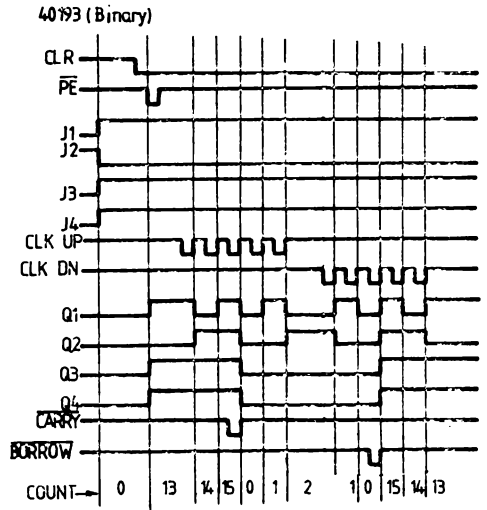
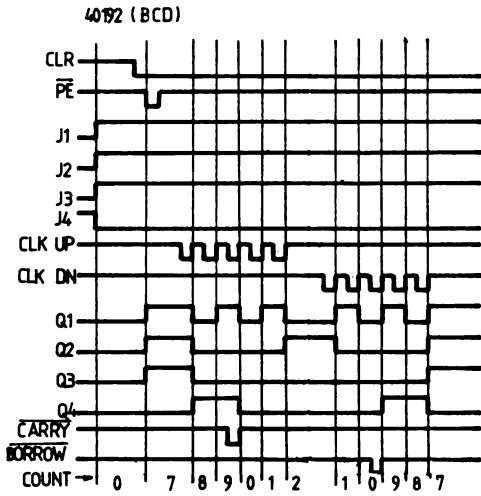

Internal logic of flip-flop

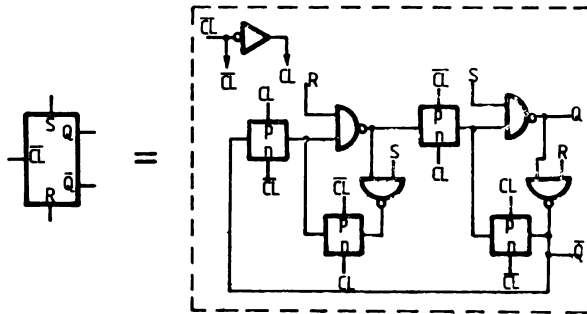

**TRUTH TABLE**

| CLOCK UP | CLOCK DOWN | PRESET ENABLE | RESET | ACTION     |
|----------|------------|---------------|-------|------------|
| 1        | 1          | 1             | 0     | COUNT UP   |
| 1        | 1          | 1             | 0     | NO COUNT   |
| 1        | 1          | 1             | 0     | COUNT DOWN |
| 1        | 1          | 1             | 0     | NO COUNT   |
| X        | X          | 0             | 0     | PRESET     |
| X        | X          | X             | 1     | RESET      |

1 = HIGH LEVEL

0 = LOW LEVEL

X = DON'T CARE

**STATIC ELECTRICAL CHARACTERISTICS**

(over recommended operating conditions)

| PARAMETER                       |                       | TEST CONDITIONS       |                       |                                |                        | VALUES           |       |           |       |                        |                   | UNIT  |         |         |
|---------------------------------|-----------------------|-----------------------|-----------------------|--------------------------------|------------------------|------------------|-------|-----------|-------|------------------------|-------------------|-------|---------|---------|
|                                 |                       | V <sub>I</sub><br>(V) | V <sub>O</sub><br>(V) | I <sub>O</sub>  <br>( $\mu$ A) | V <sub>DD</sub><br>(V) | T <sub>LOW</sub> |       | 25°C      |       |                        | T <sub>HIGH</sub> |       |         |         |
|                                 |                       |                       |                       |                                |                        | min.             | max.  | min.      | typ   | max.                   | min.              |       | max.    |         |
| I <sub>L</sub>                  | Quiescent current     | G, H types            | 0/ 5                  |                                |                        | 5                |       | 5         | 0.04  | 5                      |                   | 150   | $\mu$ A |         |
|                                 |                       |                       | 0/10                  |                                |                        | 10               |       | 10        | 0.04  | 10                     |                   | 300   |         |         |
|                                 |                       | 0/15                  |                       |                                | 15                     |                  | 20    | 0.04      | 20    |                        | 600               |       |         |         |
|                                 |                       | 0/20                  |                       |                                | 20                     |                  | 100   | 0.08      | 100   |                        | 3000              |       |         |         |
|                                 | E, F types            | 0/ 5                  |                       |                                | 5                      |                  | 20    | 0.04      | 20    |                        | 150               |       |         |         |
|                                 |                       | 0/10                  |                       |                                | 10                     |                  | 40    | 0.04      | 40    |                        | 300               |       |         |         |
|                                 |                       | 0/15                  |                       |                                | 15                     |                  | 80    | 0.04      | 80    |                        | 600               |       |         |         |
| V <sub>OH</sub>                 | Output high voltage   | 0/ 5                  |                       | < 1                            | 5                      | 4.95             |       | 4.95      |       |                        | 4.95              | V     |         |         |
|                                 |                       | 0/10                  |                       | < 1                            | 10                     | 9.95             |       | 9.95      |       |                        | 9.95              |       |         |         |
|                                 |                       | 0/15                  |                       | < 1                            | 15                     | 14.95            |       | 14.95     |       |                        | 14.95             |       |         |         |
| V <sub>OL</sub>                 | Output low voltage    | 5 /0                  |                       | < 1                            | 5                      |                  | 0.05  |           |       | 0.05                   | 0.05              | V     |         |         |
|                                 |                       | 10/0                  |                       | < 1                            | 10                     |                  | 0.05  |           |       | 0.05                   | 0.05              |       |         |         |
|                                 |                       | 15/0                  |                       | < 1                            | 15                     |                  | 0.05  |           |       | 0.05                   | 0.05              |       |         |         |
| V <sub>IH</sub>                 | Input high voltage    |                       | 0.5/4.5               | < 1                            | 5                      | 3.5              |       | 3.5       |       |                        | 3.5               | V     |         |         |
|                                 |                       |                       | 1/9                   | < 1                            | 10                     | 7                |       | 7         |       |                        | 7                 |       |         |         |
|                                 |                       |                       | 1.5/13.5              | < 1                            | 15                     | 11               |       | 11        |       |                        | 11                |       |         |         |
| V <sub>IL</sub>                 | Input low voltage     |                       | 4.5/0.5               | < 1                            | 5                      |                  | 1.5   |           |       | 1.5                    | 1.5               | V     |         |         |
|                                 |                       |                       | 9/1                   | < 1                            | 10                     |                  | 3     |           |       | 3                      | 3                 |       |         |         |
|                                 |                       |                       | 13.5/1.5              | < 1                            | 15                     |                  | 4     |           |       | 4                      | 4                 |       |         |         |
| I <sub>OH</sub>                 | Output drive current  | G, H types            | 0/ 5                  | 2.5                            |                        | 5                | -2    |           | -1.6  | -3.2                   |                   | -1.15 | mA      |         |
|                                 |                       |                       | 0/ 5                  | 4.6                            |                        | 5                | -0.64 |           | -0.51 | -1                     |                   | -0.36 |         |         |
|                                 |                       | 0/10                  | 9.5                   |                                | 10                     | -1.6             |       | -1.3      | -2.6  |                        | -0.9              |       |         |         |
|                                 |                       | 0/15                  | 13.5                  |                                | 15                     | -4.2             |       | -3.4      | -6.8  |                        | -2.4              |       |         |         |
|                                 | E, F types            | 0/ 5                  | 2.5                   |                                | 5                      | -1.53            |       | -1.36     | -3.2  |                        | -1.1              |       |         |         |
|                                 |                       | 0/ 5                  | 4.6                   |                                | 5                      | -0.52            |       | -0.44     | -1    |                        | -0.36             |       |         |         |
|                                 |                       | 0/10                  | 9.5                   |                                | 10                     | -1.3             |       | -1.1      | -2.6  |                        | -0.9              |       |         |         |
|                                 |                       | 0/15                  | 13.5                  |                                | 15                     | -3.6             |       | -3.0      | -6.8  |                        | -2.4              |       |         |         |
| I <sub>OL</sub>                 | Output sink current   | G, H types            | 0/ 5                  | 0.4                            |                        | 5                | 0.64  |           | 0.51  | 1                      |                   | 0.36  | mA      |         |
|                                 |                       |                       | 0/10                  | 0.5                            |                        | 10               | 1.6   |           | 1.3   | 2.6                    |                   | 0.9   |         |         |
|                                 |                       | 0/15                  | 1.5                   |                                | 15                     | 4.2              |       | 3.4       | 6.8   |                        | 2.4               |       |         |         |
|                                 |                       | E, F types            | 0/ 5                  | 0.4                            |                        | 5                | 0.52  |           | 0.44  | 1                      |                   | 0.36  |         |         |
|                                 | 0/10                  |                       | 0.5                   |                                | 10                     | 1.3              |       | 1.1       | 2.6   |                        | 0.9               |       |         |         |
|                                 |                       |                       | 0/15                  | 1.5                            |                        | 15               | 3.6   |           | 3.0   | 6.8                    |                   | 2.4   |         |         |
| I <sub>IH</sub> I <sub>IL</sub> | Input leakage current | G, H types            | 0/18                  | Any input                      |                        | 18               |       | $\pm$ 0.1 |       | $\pm$ 10 <sup>-5</sup> | $\pm$ 0.1         |       | $\pm$ 1 | $\mu$ A |
|                                 |                       | E, F types            | 0/15                  |                                |                        | 15               |       | $\pm$ 0.3 |       | $\pm$ 10 <sup>-5</sup> | $\pm$ 0.3         |       | $\pm$ 1 |         |
| C <sub>I</sub>                  | Input capacitance     |                       | Any input             |                                |                        |                  |       |           | 5     | 7.5                    |                   | pF    |         |         |

\* T<sub>LOW</sub> = -55°C for G, H devices; -40°C for E, F devices.

\* T<sub>HIGH</sub> = +125°C for G, H devices; +85°C for E, F devices.

The Noise Margin for both "1" and "0" level is:

- 1 V min. with V<sub>DD</sub> = 5 V
- 2 V min. with V<sub>DD</sub> = 10 V
- 2.5 V min. with V<sub>DD</sub> = 15 V

**DYNAMIC ELECTRICAL CHARACTERISTICS**

( $T_A = 25^\circ\text{C}$ ,  $C_L = 50\text{ pF}$ ,  $R_L = 200\text{ k}\Omega$ , typical temperature coefficient for all  $V_{DD}$  values is  $0.3\%/^\circ\text{C}$ , all input rise and fall times =  $20\text{ ns}$ )

| PARAMETER     |   | TEST CONDITIONS |                    | VALUES |      |      | UNIT          |
|---------------|---|-----------------|--------------------|--------|------|------|---------------|
|               |   |                 | $V_{DD}(\text{V})$ | min.   | typ. | max. |               |
| $t_{PHL}$     | Propagation delay time  |                 | 5                  |        | 250  | 500  | ns            |
| $t_{PLH}$     | Clok Up or Clok Down to Q   |                 | 10                 |        | 120  | 240  |               |
|               | Reset to Q  |                 | 15                 |        | 90   | 180  |               |
|               | $\overline{PE}$ to Q  |                 | 5                  |        | 200  | 400  | ns            |
|               |   |                 | 10                 |        | 100  | 200  |               |
|               |   |                 | 15                 |        | 70   | 140  |               |
|               | Clock Up to $\overline{\text{Carry}}$<br>Clok Down to $\overline{\text{Borrow}}$                        |                 | 5                  |        | 160  | 320  | ns            |
|               |   |                 | 10                 |        | 80   | 160  |               |
|               |   |                 | 15                 |        | 60   | 120  |               |
|               | $\overline{\text{Reset}}$ or $\overline{PE}$ to $\overline{\text{Borrow}}$ or $\overline{\text{Carry}}$ |                 | 5                  |        | 300  | 600  | ns            |
|               |   |                 | 10                 |        | 150  | 300  |               |
|               |   |                 | 15                 |        | 110  | 220  |               |
| $t_{THL}$     | Transition time   |                 | 5                  |        | 100  | 200  | ns            |
| $t_{TLH}$     |   |                 | 10                 |        | 50   | 100  |               |
|               |   |                 | 15                 |        | 40   | 80   |               |
| $t_{rem}^*$   | Removal time<br>Reset or $\overline{PE}$  |                 | 5                  | 80     | 40   |      | ns            |
|               |   |                 | 10                 | 40     | 20   |      |               |
|               |   |                 | 15                 | 30     | 15   |      |               |
| $t_w$         | Clock input pulse width<br>Reset  |                 | 5                  | 480    | 240  |      | ns            |
|               |   |                 | 10                 | 300    | 150  |      |               |
|               |   |                 | 15                 | 260    | 130  |      |               |
|               | $\overline{PE}$   |                 | 5                  |        | 120  | 240  | ns            |
|               |   |                 | 10                 |        | 85   | 170  |               |
|               |   |                 | 15                 |        | 70   | 140  |               |
|               | Clock   |                 | 5                  |        | 90   | 180  | ns            |
|               |   |                 | 10                 |        | 45   | 90   |               |
|               |   |                 | 15                 |        | 30   | 60   |               |
| $t_r$ , $t_f$ | Clock input rise or fall time   |                 | 5                  |        |      | 15   | $\mu\text{s}$ |
|               |   |                 | 10                 |        |      | 15   |               |
|               |   |                 | 15                 |        |      | 5    |               |
| $t_{CL}$      | Maximum clock input frequency   |                 | 5                  | 2      | 4    |      | MHz           |
|               |   |                 | 10                 | 4      | 8    |      |               |
|               |   |                 | 15                 | 5.5    | 11   |      |               |

\* The time required for Reset or Preset Enable control to be removed before clocking (see timing diagram).

Timing diagram defining  $t_{rem}$

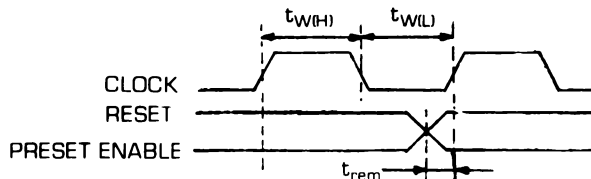

## LIQUID-CRYSTAL DISPLAY DRIVERS

- 4054 - 4 SEGMENT DISPLAY DRIVER-STROBED LATCH FUNCTION**
- 4055 - BCD TO 7-SEGMENT DECODER/DRIVER, WITH „DISPLAY-FREQUENCY“ OUTPUT**
- 4056 - BCD TO 7-SEGMENT DECODER/DRIVER WITH STROBED LATCH FUNCTION**

### GENERAL DESCRIPTION

The MMC 4054, MMC 4055, MMC 4056 (G, H types extended temperature range and the E, F types intermediate temperature range) are monolithic integrated circuits available in 16-lead dual in-line plastic or ceramic package. The MMC 4055 and MMC 4056 types are single-digit BCD-to-7-segment decoder/driver circuits that provide level-shifting functions on the chip. This feature permits the BCD input-signal swings ( $V_{DD}$  to  $V_{SS}$ ) to be the same as or different from the 7-segment output-signal swings ( $V_{DD}$  to  $V_{EE}$ ). For example, the BCD input-signals swings ( $V_{DD}$  to  $V_{SS}$ ) may be as low as 0 to  $-3V$ , whereas the output-display drive-signal swing ( $V_{DD}$  to  $V_{EE}$ ) may be from 0 to  $-5V$ . If  $V_{DD}$  to  $V_{EE}$  exceeds 15V,  $V_{DD}$  to  $V_{SS}$  should be at least 4V. The 7-segment outputs are controlled by the DISPLAY-FREQUENCY (DF) input which causes the selected segment outputs to be low, high, or a square-wave output (for liquid-crystal displays).

When the DF input is low the output segments will be high when selected by the BCD inputs. When the DF input is high, the output segments will be low when selected by the BCD inputs. When a square-wave is present at the DF input, the selected segments will have a square-wave output that is 180° out of phase with the DF input. Those segments which are not selected will have a square-wave output that is in phase with the input. DF square-wave repetition rates for liquid-crystal displays usually range from 30 Hz (well above flicker rate) to 200 Hz (well below the upper limit of the liquid crystal frequency response). The MMC 4055 provides a level-shifted high-amplitude DF output which is required for driving the common electrode in liquid-crystal displays. The MMC 4056 provides a strobed latch function at the BCD inputs. Decoding of all input combinations on the MMC 4055 and MMC 4056 provides displays of 0 to 9 as well as L,P,H,A — and a blank position. The MMC 4054 provides level shifting similar to the MMC 4055 and MMC 4056 independently strobed latches, and common DF control on 4 signal lines. The MMC 4054 is intended to provide drive-signal compatibility with the MMC 4055 and MMC 4056 7-segment decoder types for the decimal point, colon, polarity, and similar display lines. A level-shifted high-amplitude DF output can be obtained from any MMC 4054 output line by connecting the corresponding input and strobe lines to a low and high level, respectively. The MMC 4054 may also be utilized for logic-level „up conversion“ or „down conversion“. For example, input-signal swings ( $V_{DD}$  to  $V_{SS}$ ) from +5 to 0V can be converted to output-signal swings ( $V_{DD}$  to  $V_{EE}$ ) of +5 to  $-5V$ . The

level shifted function on all three types permits the use of different input-and output-signal swings. The input swings from a low level of  $V_{SS}$  to a high level of  $V_{DD}$  while the output swings from a low level of  $V_{EE}$  to the same high level of  $V_{DD}$ . Thus, the input and output swings can be selected independently of each other over a 3-to 18V range.  $V_{SS}$  may be connected to  $V_{EE}$  when no level-shift function is required. For the MMC 4054 and the MMC 4056, data are transferred from input to output by placing a high voltage level at the strobe input. A low voltage level at the strobe input latches the data input and the corresponding output segments remain selected (or non-selected) while the strobe is low. Whenever the level-shifting function is required, the MMC 4055 can be used by itself to drive a liquid-crystal display. The MMC 4056, however, must be used together with a MMC 4054 to provide the common DF output.

### FEATURES

- Operation of liquid crystals with CMOS circuits provides ultra low-power displays
- Equivalent AC output drive for liquid-crystal displays-no external capacitor required
- Voltage doubling across display ( $V_{DD} - V_{EE}$ ) = 18V results in effective 36 V (pp) drive across selected display segments
- Low-or high-output level DC drive for other types of displays
- On chip logic-level conversion for different input and output-level swings
- Full decoding of all input combinations: "0-9,L,H,P,A" and blank positions
- Input current of 100 nA at 18V and 25°C for MMC device G, H types
- 100% tested for quiescent current

**ABSOLUTE MAXIMUM RATINGS**

|            |  |                                |                  |           |                            |
|------------|--|--------------------------------|------------------|-----------|----------------------------|
| $V_{DD}^*$ | Supply voltage: G and H types<br>E and F types   | -0.5 to<br>-0.5 to             | 20<br>18         | V<br>V    |                            |
| $V_i$      | Input voltage  | -0.5 to                        | $V_{DD}+0.5$     | V         |                            |
| $I_i$      | DC input current (any one input)   |                                | $\pm 10$         | mA        |                            |
| $P_{tot}$  | Total power dissipation (per package)<br>Dissipation per output transistor<br>for $T_A$ = full package-temperature range |                                | 200              | mW        |                            |
| $T_A$      | Operating<br>temperature :   | G and H types<br>E and F types | -55 to<br>-40 to | 125<br>85 | $^{\circ}C$<br>$^{\circ}C$ |
| $T_{stg}$  | Storage temperature  |                                | -65 to           | 150       | $^{\circ}C$                |

\* All voltage values are referred to  $V_{SS}$  pin voltage

**RECOMMENDED OPERATING CONDITIONS**

|            |  |                                |                  |           |                            |
|------------|--|--------------------------------|------------------|-----------|----------------------------|
| $V_{DD}^*$ | Supply voltage: G and H types<br>E and F types | 3 to<br>3 to                   | 18<br>15         | V<br>V    |                            |
| $V_i$      | Input voltage                                  | 0 to                           | $V_{DD}$         | V         |                            |
| $T_A$      | Operating<br>temperature :                     | G and H types<br>E and F types | -55 to<br>-40 to | 125<br>85 | $^{\circ}C$<br>$^{\circ}C$ |

**CONNECTION DIAGRAM**

**MMC 4054**

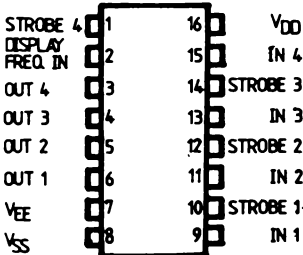

**MMC 4055**

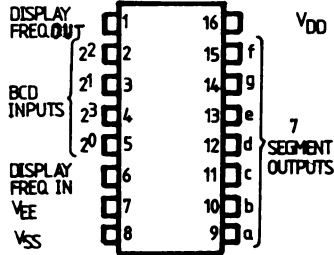

**MMC 4056**

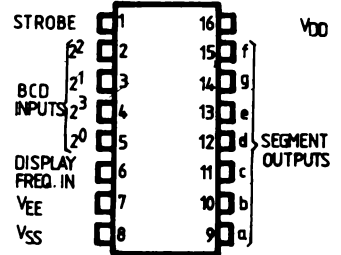

# MOTOR DRIVE CLOCK CIRCUIT

## GENERAL DESCRIPTION

The MMC 300 is a 23 stage binary counter in standard Al-gate CMOS technology in a single monolithic chip. An inverter is available for crystal oscillator application. The function of the trimmer capacitor has been taken over by the variable frequency divider comprised in the IC. Seven adjustment terminals are used to set the divider ratio to the required value with an accuracy of  $10^{-6}$ . The maximum output frequency is set when all adjustment terminals are either open-circuit or connected to pin 14. If one or more adjustment terminals are grounded (taken to pin 13) the output frequency decreases. The oscillator frequency divided by four may be checked at the test output (pin 8). With an oscillator frequency of 4.194812 MHz the series-connected push-pull output stage supplies a symmetrical square wave signal with a pulse duty factor of 0.5 and a repetition frequency of 0.5 Hz if the variable frequency divider is set to its medium value.

The MMC 300 is available in 14 lead dual in-line and ceramic plastic package.

## FEATURES

- Low quiescent power dissipation
- Fully protected inputs
- Adjustable frequency divider in 127 steps
- Test output available

## ABSOLUTE MAXIMUM RATINGS

|           |  |         |          |             |
|-----------|--|---------|----------|-------------|
| $V_{DD}$  | Supply voltage MMC 300-1                     | -0.3 to | + 10     | V           |
|           | MMC 300                                      | -0.3 to | + 17     | V           |
| $I_{II}$  | Output current                               |         | $\pm 60$ | mA          |
| $P_{tot}$ | Total dissipation at $T_{amb} = 25^{\circ}C$ |         | 200      | mW          |
| $T_{op}$  | Operating temperature range                  | -40 to  | +85      | $^{\circ}C$ |
| $T_{stg}$ | Storage temperature range                    | -55 to  | +125     | $^{\circ}C$ |

## RECOMMENDED OPERATING CONDITIONS

|          |                           |             |          |             |
|----------|---------------------------|-------------|----------|-------------|
| $V_{DD}$ | Supply voltage: MMC 300-1 | 5 to        | 9        | V           |
|          | MMC 300                   | 6 to        | 16.5     | V           |
| $V_i$    | Input voltage             | $V_{DD}$ to | $V_{SS}$ | V           |
| $I_{II}$ | Output current            |             | 40       | mA          |
| $T_{op}$ | Operating temperature     | -40 to      | +85      | $^{\circ}C$ |

## CONNECTION DIAGRAM

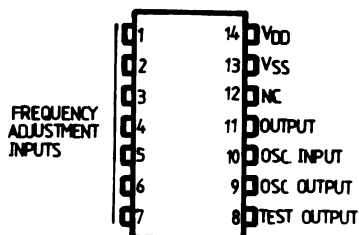

**STATIC ELECTRICAL CHARACTERISTICS**

| PARAMETER |                                |                      | TEST CONDITIONS                                  |          | VALUES        |          |              | UNIT   |
|-----------|--------------------------------|----------------------|--|----------|---------------|----------|--------------|--------|
|           |                                |                      | $V_o$  | $V_{DD}$ | 25°C          |          |              |        |
|           |                                |                      | V  | V        | min.          | typ.     | max.         |        |
| $V_{OH}$  | Output high voltage            | MMC 300—1<br>MMC 300 | $I_{OH} = 0$                                     | 6<br>12  | 5.99<br>11.99 | 6<br>12  |              | V<br>V |
| $V_{OL}$  | Output low voltage             | MMC 300—1<br>MMC 300 | $I_{OL} = 0$                                     | 6<br>12  |               | 0<br>0   | 0.01<br>0.01 | V<br>V |
| $I_{DN}$  | Output Drive current N—channel | MMC 300—1<br>MMC 300 |  | 2<br>2   | 6<br>12       | 20<br>33 | 25<br>40     | mA     |
| $I_{DP}$  | Output drive current P—channel | MMC 300—1<br>MMC 300 |  | 4<br>10  | 6<br>12       | 20<br>33 | 25<br>40     |        |
| $I_{ON}$  | Current consumption            | MMC 300—1<br>MMC 300 |  |          | 6<br>12       |          | 3<br>3       |        |
|           |                                |                      | $I_O = 0$ , at quartz frequency of 4. 194812 MHz |          |               |          |              |        |

**3**

**DYNAMIC ELECTRICAL CHARACTERISTICS**

( $T_{amb} = 25^\circ\text{C}$ , quartz frequency = 4.194812 MHz)

| PARAMETER                |                                   |                      | TEST CONDITIONS |             | VALUES |            |      | UNIT     |
|--------------------------|-----------------------------------|----------------------|-----------------|-------------|--------|------------|------|----------|
|                          |                                   |                      | $V_{DD}$<br>(V) |             | min.   | typ.       | max. |          |
| $f_T$                    | Frequency test output             | MMC 300—1<br>MMC 300 | 6<br>12         |             |        | 1.048703   |      | MHz      |
| $f_o^*$                  | Output frequency                  | MMC 300—1<br>MMC 300 | 6<br>12         |             |        | 0.5<br>0.5 |      | Hz<br>Hz |
| $\frac{\Delta f_o}{f_o}$ | Range output frequency adjustment |                      |                 |             |        | $\pm 121$  |      | ppm      |
| $R_o$                    | Output resistance                 |                      |                 | $R_L = 300$ |        |            | 100  | $\Omega$ |

\* At the centre position of the variable divider

**BLOCK DIAGRAM**

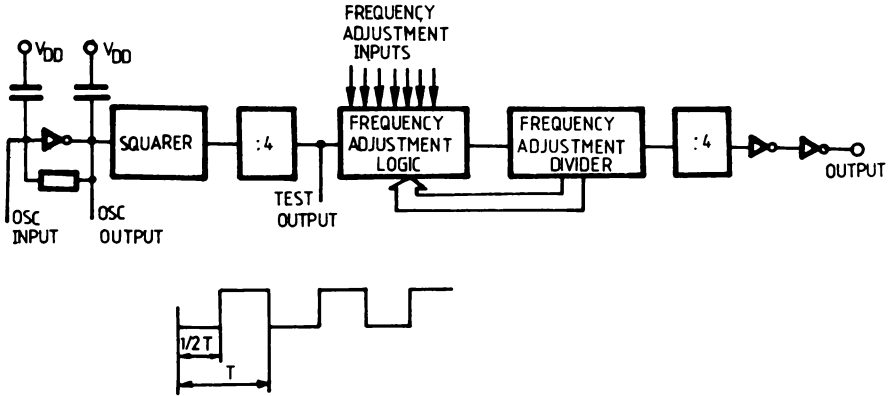

**TYPICAL APPLICATIONS**

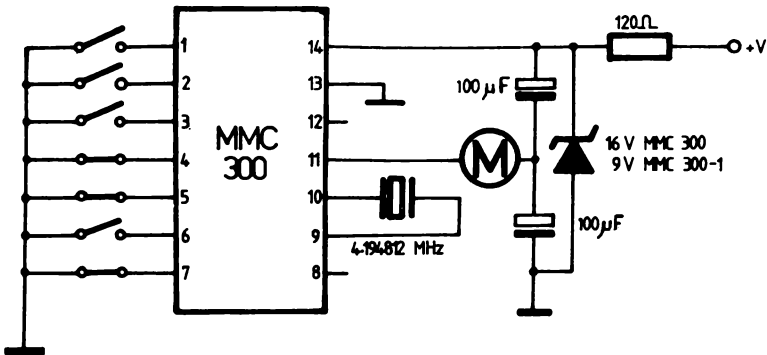



# AUTO CLOCK

## GENERAL DESCRIPTION

The MMC 351 is a metal gate CMOS integrated circuit that provides or controls all signals needed for a 3 1/2-digit LED watch. The display format is 12 hours, with an AM/PM indicator. The circuit time base is a 32768 Hz crystal controlled oscillator. The time base frequency is successively divided to provide drive signals for a multiplexed 7-segment display. In order to drive the display, the watch requires a BCD-to-7 segment decoder (the MMC4511, for example). The device operates from a single 3V to 18V supply. The MMC351 is available in a 16-lead dual-in-line package.

## FEATURES

- 32768 Hz crystal controlled oscillator
- wide supply voltage range: 3 to 18V
- low current consumption (3mA)
- 12 hours display format
- on-chip oscillator

## CONNECTION DIAGRAM

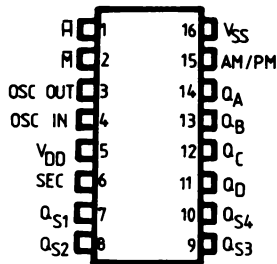

## BLOCK DIAGRAM

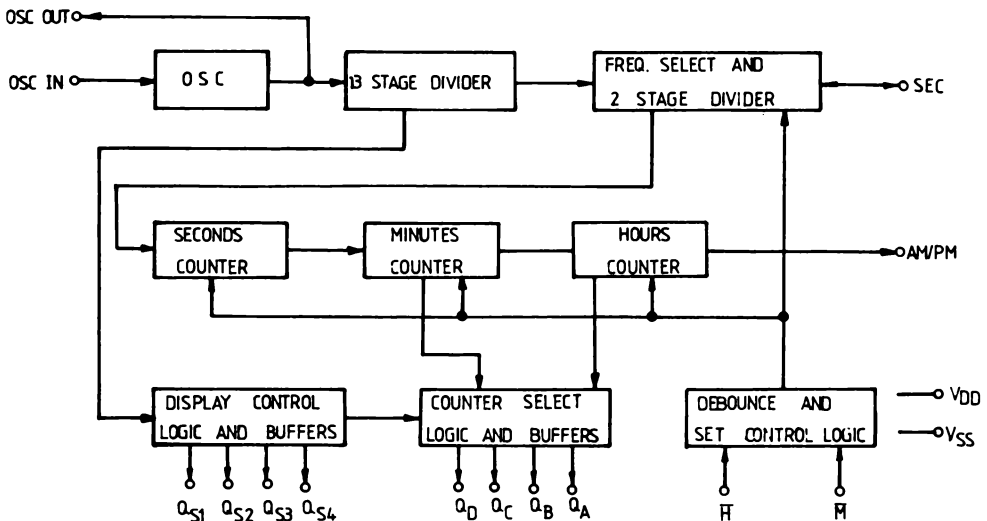

**FUNCTIONAL DESCRIPTION**

**Time base:**

The time base of the watch is provided by connecting a crystal controlled RC network to the on-chip CMOS inverter/amplifier.

**Display multiplexing:**

Outputs from each counter are time-division multiplexed to provide digit-sequential access to the time data. The  $3\frac{1}{2}$  digits of the display are multiplexed with a 22% duty cycle, 1024 Hz signal.

**Time display:**

The hour information is displayed in digit positions 1 and 2, while minute information in digit positions 3 and 4. There are an AM/PM indicator and a seconds serially output.

**Time setting:**

Closure of the 'M' switch will advance minutes at a 2 Hz rate, with no advance of the hours counter and with seconds counter in 00. Closure of the 'H' switch will advance hours counter at a 1 Hz rate. When POWER ON, minutes counter must be set first.

**TYPICAL APPLICATIONS**

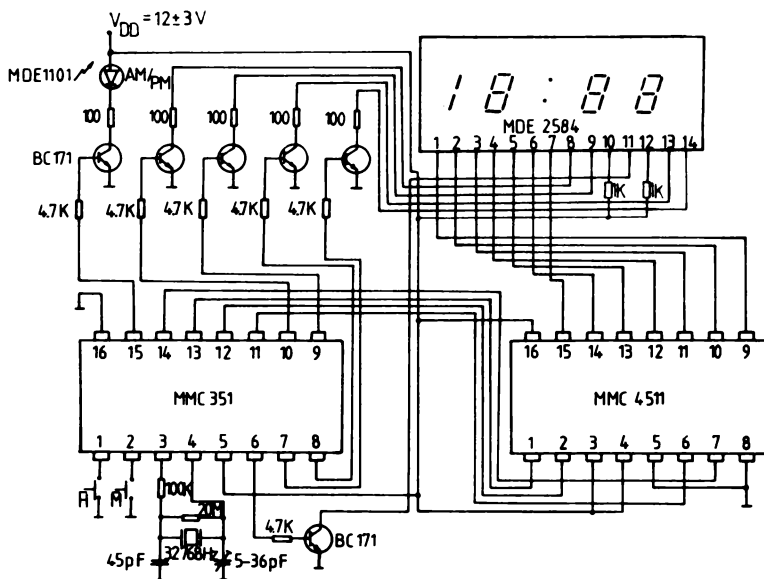

# LOOP DISCONNECT DIALLER

## GENERAL DESCRIPTION

The MMC 760 Loop Disconnect Dialler provides the features to implement a pulse dialler with redial. It can be operated directly by the telephone line current and converts a single per key contact into the corresponding pulse signals to simulate the rotary dialler.

When in stand-by condition it requires only few microamperes to maintain the storage of the last call. Keyboard inputs are fully static; outputs are provided to pulse the telephone line and to mute the receiver during impulsing.

Other features are: pin selectable long distance call inhibition, 24 digit memory in which can be introduced a maximum of 8 access pauses, pin selectable redial inhibition and out pulsing inhibition for operation with payment-card telephones.

Redial can be achieved with two pin selectable procedures.

The device requires an inexpensive 455 kHz ceramic resonator and is designed to minimize external components.

The unique design of the power-on reset circuit can avoid the need for a special dedicated spring in the hook switch.

The loop is disconnected for a time longer than 300 ms when fraudulent dialling is tried with the hook or any external device by sensing the line condition at the input LS.

The MMC 760 is realized in low voltage CMOS technology and can be easily mask programmed to meet all administration standards.

## FEATURES

- Direct telephone line operation
- Low voltage CMOS technology
- Low power consumption in stand-by m.
- Pin selectable long distance call inhibition
- Pin selectable output pulsing inhibition
- 8 Selectable access pauses
- Wide selection of mask options for 1,5 — 1,6 — 1,66 — 2 B/W ratios

## ABSOLUTE MAXIMUM RATINGS\*

|               |                             |                              |    |
|---------------|-----------------------------|------------------------------|----|
| $V_{DD}^{**}$ | Supply voltage              | 5                            | V  |
| $V_i$         | Input voltage               | $V_{SS}-0.5$ to $V_{DD}+0.5$ | V  |
| $P_{tot}$     | Total power dissipation     | 400                          | mW |
| $T_A$         | Operating temperature range | -25 to +50                   | °C |
| $T_{stg}$     | Storage temperature range   | -65 to +85                   | °C |

\* Stresses above those listed under "Absolute Maximum Ratings" may cause permanent damage to the device. This is a stress rating only and functional operation of the device at these or any other conditions above those indicated in the operational sections of this specification is not implied. Exposure to absolute maximum rating conditions for extended periods may affect device reliability.

\*\* All voltages are referred to  $V_{SS}$  pin voltage.

## CONNECTION DIAGRAM

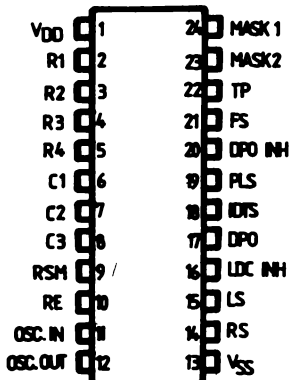

**STATIC ELECTRICAL CHARACTERISTICS**

(T<sub>A</sub> = -25°C to +50°C)

|  |                          | PARAMETER   | TEST CONDITIONS                                  | min.                | typ. | max.                  | UNIT |  |
|--|--------------------------|---|--|---------------------|------|-----------------------|------|--|
| Supply                                 | V <sub>DD</sub>          | Supply voltage  |  | 2.2                 | 2.5  | 5                     | V    |  |
|  | I <sub>DD</sub>          | Operating supply current  | V <sub>DD</sub> = 2.5 V f <sub>o</sub> = 455 kHz |                     |      | 0.5                   | mA   |  |
|  | I <sub>DD</sub> stand-by | Stand-by supply current (oscillator, off, no external load connected) | V <sub>DD</sub> = 2.5 V                          |                     |      | 25                    | μA   |  |
| Keyboard inputs                        | Row inputs               |   |  |                     |      |                       |      |  |
|  | I <sub>IH</sub>          | Input high current  | V <sub>DD</sub> = 2.5 V                          |                     | 60   | 80                    | μA   |  |
|  | I <sub>IL</sub>          | Input low current   | V <sub>IH</sub> = 2.5 V                          |                     |      | 1                     | μA   |  |
|  | V <sub>IH</sub>          | Input threshold voltage   | V <sub>IL</sub> = 0 V                            | 1                   |      |                       | V    |  |
|  | Column inputs            |   |  |                     |      |                       |      |  |
|  | I <sub>IH</sub>          | Input high current  | V <sub>DD</sub> = 2.5 V                          |                     |      | 1                     | μA   |  |
|  | I <sub>IL</sub>          | Input low current   | V <sub>IH</sub> = 2.5 V                          |                     | -60  | 80                    | μA   |  |
|  | V <sub>IL</sub>          | Input threshold voltage   | V <sub>IL</sub> = 0 V                            |                     |      | V <sub>DD</sub> - 1 V | V    |  |
| Oscillator                             | OSC IN                   |   |  |                     |      |                       |      |  |
|  | I <sub>IH</sub>          | Input high current  | V <sub>DD</sub> = 2.5 V, V <sub>IH</sub> = 2.5 V |                     |      | 1                     | μA   |  |
|  | I <sub>IL</sub>          | Input low current   | V <sub>IL</sub> = 0 V                            |                     |      | -1                    | μA   |  |
|  | OSC OUT                  |   |  |                     |      |                       |      |  |
|  | I <sub>OH</sub>          | Output drive current  | V <sub>DD</sub> = 2.5 V, V <sub>OH</sub> = 2 V   | -150                |      |                       | μA   |  |
|  | I <sub>OL</sub>          | Output sink current   | V <sub>DD</sub> = 2.5 V, V <sub>OL</sub> = 0.5 V | 150                 |      |                       | μA   |  |
| Mask output                            | I <sub>OH</sub>          | Output drive current  | V <sub>DD</sub> = 2.5 V, V <sub>OH</sub> = 1.4 V | -1                  |      |                       | mA   |  |
|  | I <sub>OL</sub>          | Output sink current   | V <sub>DD</sub> = 2.2 V, V <sub>OL</sub> = 0.1 V |                     | 20   |                       | μA   |  |
| DPO                                    | I <sub>OL</sub>          | Output sink current   | V <sub>DD</sub> = 2.2 V, V <sub>OL</sub> = 0.4 V | 1                   |      |                       | mA   |  |
|  | I <sub>OFF</sub>         | Output leakage current  | V <sub>DD</sub> = 2.5 V                          |                     |      | +1                    | μA   |  |
| LDC INH<br>DPO INH<br>PLS<br>RSM<br>RE | I <sub>IH</sub>          | Input high current  | V <sub>DD</sub> = 2.5 V, V <sub>IH</sub> = 2.5 V |                     |      | 1                     | μA   |  |
|  | I <sub>IL</sub>          | Input low current   | V <sub>DD</sub> = 2.5 V, V <sub>IL</sub> = 0 V   |                     |      | -1                    | μA   |  |
|  | V <sub>IH</sub>          | Input high voltage  |  | 0.7 V <sub>DD</sub> |      |                       | V    |  |
|  | V <sub>IL</sub>          | Input low voltage   |  |                     |      | 0.3 V <sub>DD</sub>   | V    |  |
| LS                                     | I <sub>IH</sub>          | Input high current  | V <sub>DD</sub> = 2.5 V V <sub>IH</sub> = 2.5 V  |                     |      | 1                     | μA   |  |
|  | I <sub>IL</sub>          | Input low current   | V <sub>DD</sub> = 2.5 V V <sub>IL</sub> = 0 V    | -100                | -160 | -250                  | μA   |  |
|  | V <sub>IH</sub>          | Input high voltage  |  | 0.7 V <sub>DD</sub> |      |                       | V    |  |
|  | V <sub>IL</sub>          | Input low voltage   |  |                     |      | 0.3 V <sub>DD</sub>   | V    |  |

|    | PARAMETER |                        | TEST CONDITIONS                  | min. | typ. | max. | UNIT         |   |
|----|-----------|------------------------|----------------------------------|------|------|------|--------------|---|
| RS | $I_{OH}$  | Output drive current   | $V_{DD} = 2.5 V, V_{OH} = 1.8 V$ | -20  |      | 1    | $\mu A$      |   |
|    | $I_{OL}$  | Output leakage current |                                  |      |      |      | $\mu A$      |   |
|    | $V_{IH}$  | Input high voltage     |                                  |      |      |      | 0.8 $V_{DD}$ | V |
|    | $V_{IL}$  | Input low voltage      |                                  |      |      |      | 0.2 $V_{DD}$ | V |

**DYNAMIC ELECTRICAL CHARACTERISTICS**

( $T_A = -25^{\circ}C$  to  $+50^{\circ}C$ )

|               | PARAMETER                                     | TEST CONDITIONS                                | VALUES                     |      |            | UNIT |          |
|---------------|---|--|----------------------------|------|------------|------|----------|
|               |   |  | min.                       | typ. | max.       |      |          |
| $t_{ACC}$     | Key access time after last bounce             | for all<br>$f_0 = 455 kHz$<br>$V_{DD} = 2.5 V$ |                            | 5.5  |            | ms   |          |
| $t_{OSC}$     | Oscillator start-up time                      |  |                            |      | 60         | ms   |          |
| $t_{MASK}$    | Mask 1, Mask 2 pulse duration                 |  |                            | 20   |            | ms   |          |
| $t_{DM}$      | Mask 1, Mask 2 delay time with respect to DPO |  |                            | 50   |            | ms   |          |
| $t_{PD}$      | Pre-digital pause                             |  |                            | 400  |            | ms   |          |
| $t_{DPO}$     | DPO period                                    |  | FS = 0<br>FS = 1           |      | 50<br>100  |      | ms<br>ms |
| $t_B / t_M$   | Break to make ratio                           |  |                            |      | 1.6        |      |          |
| $t_{ID}$      | Interdigit time                               |  | IDTS = 0<br>IDTS = 1       |      | 800<br>400 |      | ms<br>ms |
| $t_{RES}$     | Minimum line break before reset               |  |                            |      | 150        |      | ms       |
| $t_{OTO}$     | Oscillator turn-off time after clear-down     |  | LDC INH = 0<br>LDC INH = 1 |      | 150<br>300 |      | ms<br>ms |
| $t_{LDC INH}$ | Line break time when LDC INH = 1              |  |                            | 300  |            | ms   |          |

**FUNCTIONAL DESCRIPTION**

**Oscillator (OS IN-OS OUT)**

The oscillator has been designed to work with an inexpensive ceramic resonator ( $f_0 = 455 kHz$ ); it requires two external load capacitors (100 pF) and the inverter feedback resistor. The oscillator starts after LS (line sense) is taken low; it comes back to the stand-by mode after LS has gone high for at least 150 ms (or 300 ms if LDC-INH high).

**Keyboard (R<sub>1</sub> to R<sub>4</sub>, C<sub>1</sub> to C<sub>3</sub>)**

MMC 760 is designed to work with a single contact keyboard. A valid key entry is recorded when a single row pin is connected to a single column pin. All the input combinations except a single row and a single column are not recognized. A valid key is entered after 5ms from the last key bounce.

**Outpulsing inhibition (DPO INH)**

If this pin is low, digits can be entered into the memory but they are not sent on the line; when DPOINH goes high the stored digits are sent on the line. This function is realized to allow operations with payment card telephones in which it is sometimes needed to assess the validity of the payment-card.

### Dial pulse output (DPO)

When a valid key is recognized the line must be opened and closed at a fixed rate and the total number of break pulses corresponds to the number of the selected key (10 line breaks are associated to the key „0“). DPO is an open drain output; line breaks occur when DPO is active to ground.

### Mask Outputs (MASK 1, MASK 2)

The Mask outputs are used to mute the speech circuit during signalling. In telephones using conventional speech circuits muting is generally achieved by short-circuiting with a two-winding, bistable reed-relay. In this case MASK 1 and MASK 2 provide pulse outputs to drive the winding which close and open the contact respectively.

In telephones with electronic speech circuits muting is implemented electronically. In this case a metal option transforms MASK 1 into a signal which remains high throughout signalling.

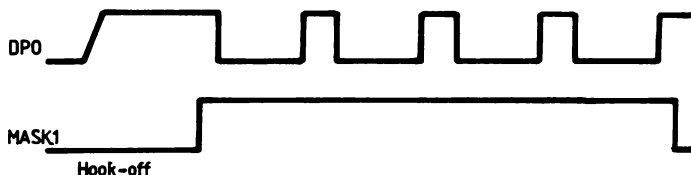
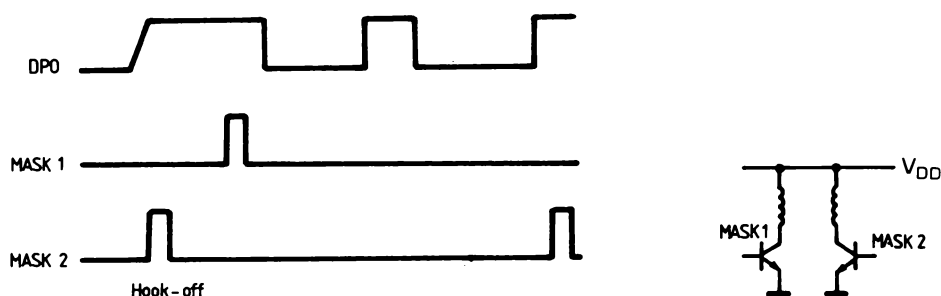

### Redial enable (RE)

Redial of the last call is possible according to the procedures described below only if RE is high. Redial is never allowed when RE is low.

### Redial Selection Mode (RSM)

The last number redialling facility operates in two modes. In the first (RSM high) the key sequence\*#\* 0 will repeat the last number dialled. The last number memory can be cleared by the # key. In the second case (RSM low) the last number dialled is only stored if the key\*# is pressed before replacing the handset. As before, the sequence\*\* 0 starts the last number repeat. In both cases the stored number is unaffected by incoming calls. The redial request can be simplified by a mask option to the single key\*#, instead of the sequence\*\* 0.

### Pause length selection (PLS)

Interdigit pauses are available to interrupt outpulsing to give to the exchange the possibility of switching from a private to a public line. The device memorizes automatically a pause when the first digit is zero; a maximum of 7 pauses can be added during dialling by selecting key\*. These pauses are active only during redialling and have a duration of 3 sec if PLS is low or 20 sec if PLS is high; in both cases pause duration can be shortened pushing key\*.

**Line sense (LS)**

This input senses if the line loop is closed or not

- LS = high means loop open
- LS = low means loop closed

When LS is kept high for more than 150 ms the circuit is reset (if LDCINH = 0). When LDCINH = 1 reset occurs after 300 ms.

**Reset (RS)**

This input/output pin is used to turn off the oscillator when line interrupts of more than 150 ms are sensed; it is also used as a power-on reset in applications where redial is not allowed. When the hand-set is picked-up and  $V_{DD}$  increases over its minimum value, the oscillator starts and an external capacitor is charged above a fixed threshold level by an opendrain P-ch. transistor driven by a 150 kHz clock. Reset occurs after a line interrupt of more than 150 ms; the pull-up transistor goes off and the capacitor discharges through a resistor to GND level.

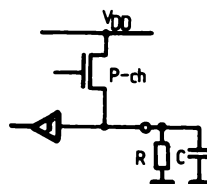
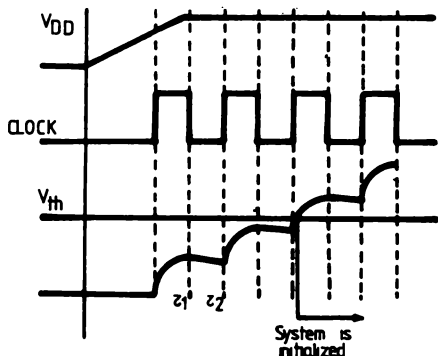

**Long distance call inhibit (LDC INH)**

When this input is taken high long distance calls are inhibited; if the first digit is a 0 DPO goes low interrupting the line for a time longer than 300 ms. The same applied when fraudulent dialling is tried with the hook or any external device by sensing the line condition at the input LS. When INH is low this facility is inoperative.

**Test pin (TP)**

When this input is taken low all the timing values are divided by 100. In this way the length of the testing operations is greatly reduced. This pin has an internal pull-up.

**BLOCK DIAGRAM**

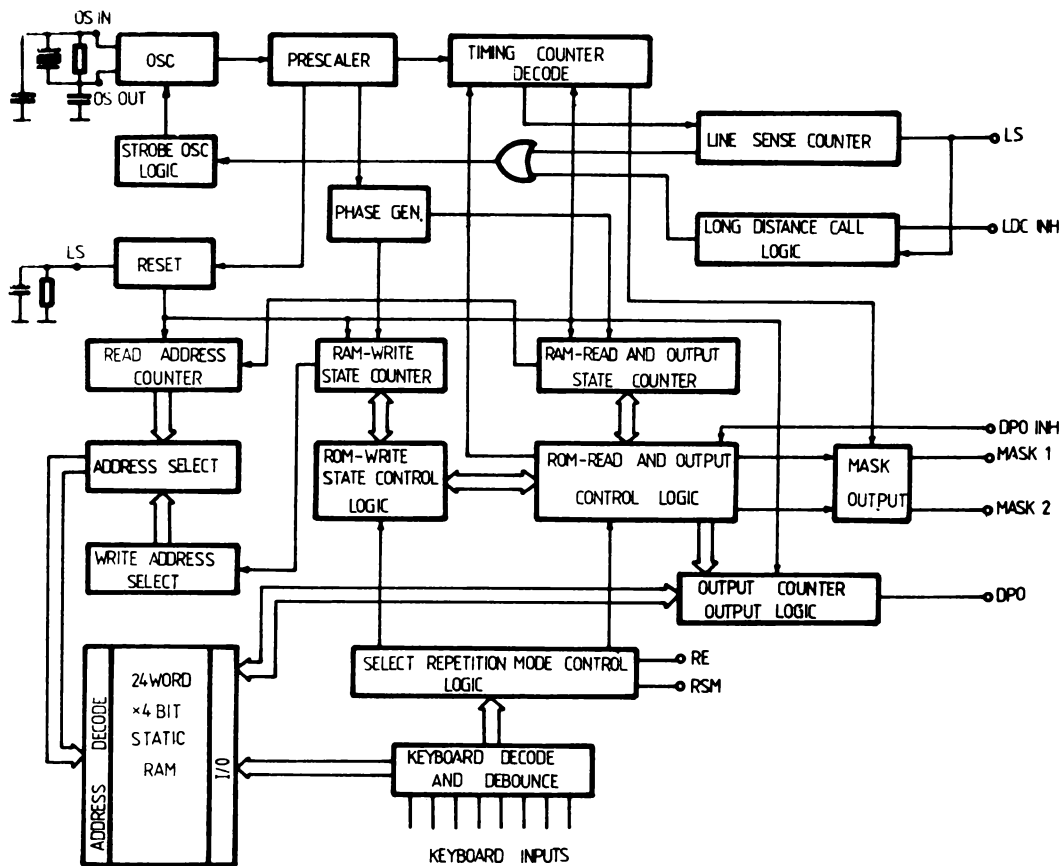

**TYPICAL APPLICATIONS**

Typical serial applications

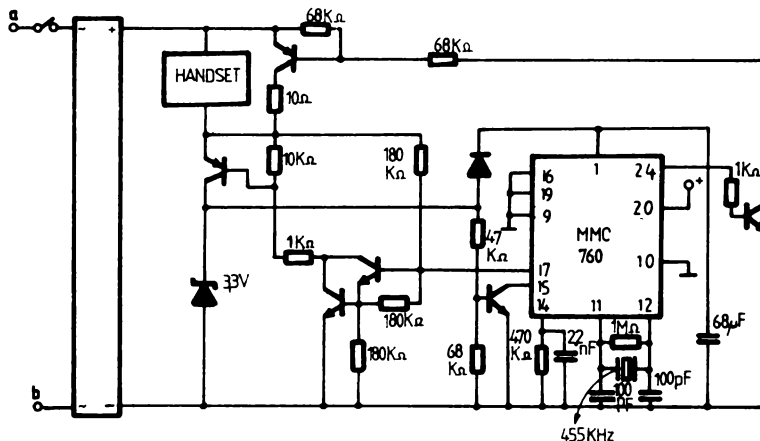



With bistable relay

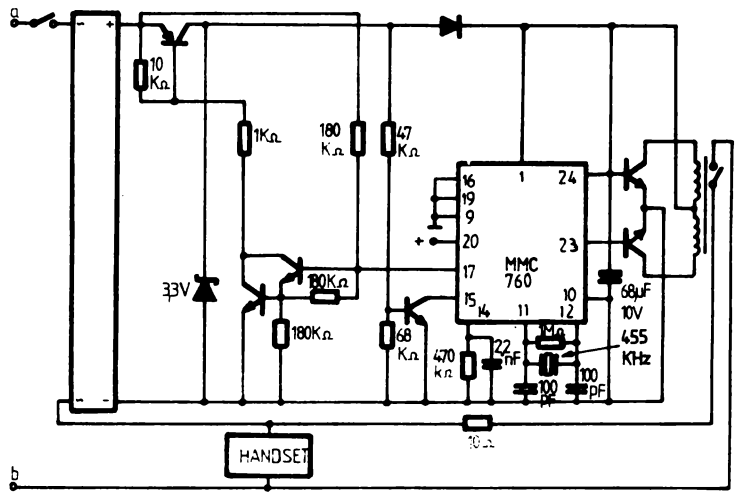

Pulse dialler with redial

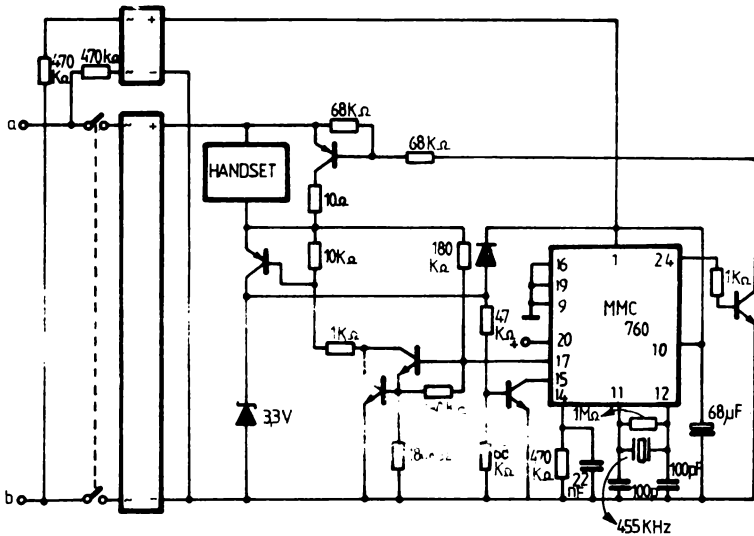

**TIMING DIAGRAM**

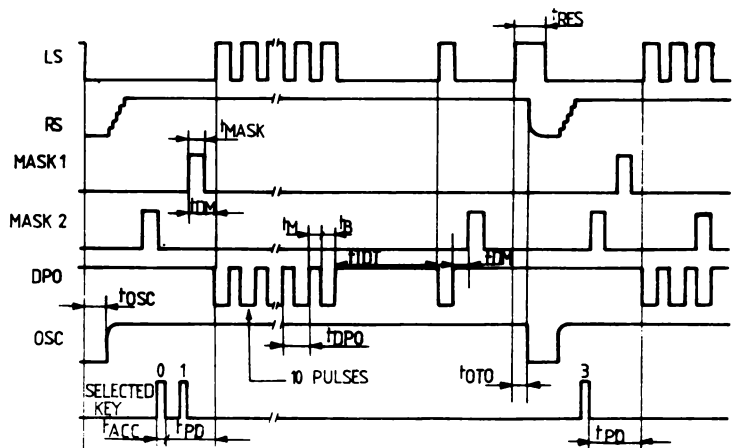

# DUAL TONE MULTI-FREQUENCY GENERATOR

## GENERAL DESCRIPTION

The MMC 761 provides all the tone frequency pairs required for a DTMF Dialling System. Tones are obtained from an inexpensive quartz crystal followed by two independent programmable dividers. The dividing ratio is controlled by the selected key. Keyboard format is 4 rows x 4 columns and a key is valid when a column and a row are connected together. Internal logic prevents the transmission of illegal tones when more than one key is pressed. Individual tones can be obtained by grounding a column input or connecting a row input to  $V_{DD}$ . If no key is selected the oscillator turns off and the linear parts are strobed to decrease the total power consumption. A debounce output is available, to indicate that a key has been selected. D/A conversion is accomplished by a capacitive network allowing very low power consumption, very low distortion and an exceptional stability of tone level against temperature variations.

The tones are mixed in a resistive network; a unity gain amplifier is provided to realize a two pole active filter with only four external passive components.

The MMC 761 utilizes low voltage CMOS technology and is available in 18 pin dual-in-line plastic or ceramic package.

## FEATURES

- 2.5 to 5 V supply range.
- Very low power consumption
- Internal pull-up or pull-down resistor with diode protection on all keyboard inputs
- On-chip crystal controlled oscillator with integrated feedback resistor and load capacitors
- Low harmonic distortion
- Fixed pre-emphasis on high-group tones
- Fast start-up time
- Low power consumption in stand-by mode
- Mute output
- One contact per key

## ABSOLUTE MAXIMUM RATINGS

|            |                             |         |              |    |
|------------|-----------------------------|---------|--------------|----|
| $V_{DD}^*$ | Supply voltage:             | -0.5 to | +5.5         | V  |
| $V_I$      | Input voltage               | -0.3 to | $V_{DD}+0.5$ | V  |
| $P_{tot}$  | Power dissipation           |         | 400          | mW |
| $T_A$      | Operating temperature range | -25 to  | +50          | °C |
| $T_{stg}$  | Storage temperature range   | -55 to  | +125         | °C |

\* All voltages are referred to  $V_{SS}$  pin voltage

## CONNECTION DIAGRAM

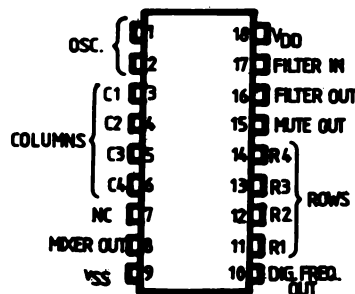

**ELECTRICAL CHARACTERISTICS**

(All parameters are tested at  $T_A = 25^\circ\text{C}$ )

| PARAMETER                 |           | TEST CONDITIONS   | VALUES                                    |      |      | UNIT               |                  |
|---------------------------|-----------|---|---|------|------|--------------------|------------------|
|                           |           |   | min.                                      | typ. | max. |                    |                  |
| <b>DC Characteristics</b> |           |   |   |      |      |                    |                  |
| Supply                    | $V_{DD}$  | Voltage supply voltage  |   | 2.5  | 3    | 5                  | V                |
|                           | $I_{DD}$  | Operating supply current  | $V_{DD}=2.5\text{V}$                      |      |      | 2                  | mA               |
|                           | $I_{DDO}$ | Stand-by supply current   |   |      |      | 0.5                | mA               |
| Row inputs                | $I_{IH}$  | High level input current  | $V_{DD}=2.5\text{V}$ $V_{IH}=2.5\text{V}$ |      | 60   | 80                 | $\mu\text{A}$    |
|                           | $I_{IL}$  | Low level input current   | $V_{DD}=2.5\text{V}$ $V_{IL}=0\text{V}$   |      |      | 1                  | $\mu\text{A}$    |
|                           | $V_{IH}$  | High level input threshold voltage                              |   | 1    |      |                    | V                |
| Column inputs             | $I_{IH}$  | High level input current  | $V_{DD}=2.5\text{V}$ $V_{IN}=2.5\text{V}$ |      |      | 1                  | $\mu\text{A}$    |
|                           | $I_{IL}$  | Low level input current   | $V_{DD}=2.5\text{V}$ $V_{IL}=0\text{V}$   |      | -60  | -80                | $\mu\text{A}$    |
|                           | $V_{IL}$  | Low level input threshold voltage                               |   |      |      | $V_{DD}-1\text{V}$ | V                |
| Oscillator                | $I_{IH}$  | High level input current  | $V_{DD}=3\text{V}$ $V_{IN}=3\text{V}$     |      |      | 1                  | $\mu\text{A}$    |
|                           | $I_{IL}$  | Low level input current   | $V_{DD}=3\text{V}$ $V_{IL}=0\text{V}$     |      |      | 1                  | $\mu\text{A}$    |
|                           | $I_{OH}$  | High level output current                                       | $V_{DD}=2.5\text{V}$ $V_{OH}=2\text{V}$   | -300 | -500 |                    | $\mu\text{A}$    |
|                           | $I_{OL}$  | Low level output current  | $V_{DD}=2.5\text{V}$ $V_{OL}=0.5\text{V}$ | 300  | 500  |                    | $\mu\text{A}$    |
| Digit. freq. output       | $I_{OL}$  | Low level input current (open drain output)                     | $V_{DD}=3\text{V}$ $V_{OL}=1\text{V}$     | 200  |      |                    | $\mu\text{A}$    |
| Filter                    | $V_O$     | Output DC voltage without tones                                 | $V_{DD}=2.5\text{V}$                      |      |      | 200                | mV               |
|                           | $V_O$     | Output DC voltage with 2 tones                                  | $V_{DD}=2.5\text{V}$ note 2.              | 0.81 | 0.84 | 0.87               | V                |
| Mute output               | $I_{OH}$  | Output drive current  | $V_{DD}=2.5\text{V}$ $V_{OH}=1.5\text{V}$ | 100  |      |                    | $\mu\text{A}$    |
|                           | $I_{OL}$  | Output sink current   | $V_{DD}=2.5\text{V}$ $V_{OL}=1\text{V}$   | 20   |      |                    | $\mu\text{A}$    |
| <b>AC Characteristics</b> |           |   |   |      |      |                    |                  |
| Osc                       | $R_F$     | Feedback oscillator resistance                                  |   | 4    | 4.5  |                    | $\text{M}\Omega$ |
|                           | $C_I$     | Input capacitance to $V_{DD}$                                   |   |      | 9.5  | 10.5               | pF               |
|                           | $C_O$     | Output capacitance to $V_{DD}$                                  |   |      |      | 10.5               | 11.5             |
| Filter-Mixer              | $Z_{O1}$  | Output dynamic impedance with 2 tones                           | $V_{DD}=2.5\text{V}$                      |      | 10   |                    | k $\Omega$       |
| Filter-Mixer              | $Z_{O2}$  | Output dynamic impedance with 2 tones                           | $V_{DD}=2.5\text{V}$                      |      | 2.5  |                    | k $\Omega$       |
| characteristics           | $V_{LF}$  | Low frequency tones amplitude at pin 14                         | $V_{DD}=2.5\text{V}$                      | 150  | 175  | 200                | mVpp             |
|                           | $V_{HF}$  | High frequency tones amplitude at pin 14                        | $V_{DD}=2.5\text{V}$                      | 195  | 220  | 245                | mVpp             |
| Ton                       |           | Unwanted frequency components at $f = 3.4\text{ kHz}$ at 50 kHz |   |      |      | -33<br>-80         | dBm<br>dBm       |
|                           |           | Total harmonic distortion for a single frequency                | $V_{DD}=2.5\text{ V}$                     |      |      | 2                  | %                |

Note 1: The value of AC output components ( $V_{LF}$ ,  $V_{HF}$ ) at two different conditions of supply voltages can be relates as follows:

$$V_{LF} = V_{LF} \frac{V_{DD'}}{V_{DD}} \qquad V_{HF} = V_{HF} \frac{V_{DD'}}{V_{DD}}$$

|       | PARAMETER                | TEST CONDITIONS       | VALUES |      |      | UNIT |
|-------|--------------------------|-----------------------|--------|------|------|------|
|       |                          |                       | min.   | typ. | max. |      |
| $t_s$ | Start up time            | $V_{DD}=2.5\text{ V}$ |        | 3    | 5    | ms   |
| $t_r$ | Supply voltage rise time | $V_{DD}=2.5\text{ V}$ |        |      | 250  | ms   |

Note 1: The value of DC output component at two different condition of supply voltages, with two tones activated, can be related as follows:

$$V_{DC'} = V_{DC} \frac{V_{DD'}}{V_{DD}}$$

**BLOCK DIAGRAM**

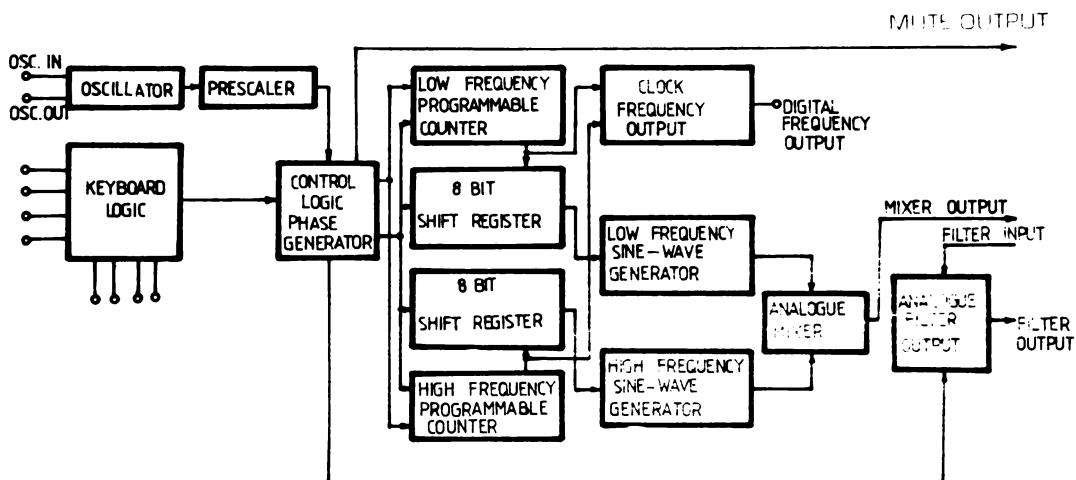

# CMOS CLOCK GENERATOR

## GENERAL DESCRIPTION

The MMC 9500 is a CMOS circuit designed to generate the two phase clock required by the MMP 9100 Push Button Dialler and the repertory dialler circuit. It consists of an RC oscillator, a level shifter, a 2 phase clock generator and driver, and a clocked D-type bistable. The RC oscillator is set by external components to run at 36 kHz and is normally operated from a 4 V supply to minimize power consumption. The oscillator output is shifted and used to drive the two phase clock generator which is normally run on a 14 V supply. The D-type bistable is either used as a reset generator for the MMP 9100, or it is used to drive a voltage multiplier to generate the 14 V supply.

## FEATURES

- Generates 2 phase clock from single power supply
- Operates with MMP 9100 Push Button Dialler
- Very low power consumption, allowing use of line powered telephones
- Minimize external components in push button telephones
- Stable generation of clock frequencies

## ABSOLUTE MAXIMUM RATINGS

|   |       |    |        |
|---|-------|----|--------|
| Voltage at any pin with respect to $V_{SS}$ | -18V  | to | +0.3 V |
| Storage temperature $T_{stg}$               | -65°C | to | 150°C  |
| Operating temperature $T_A$                 | -25°C | to | 70°C   |

## RECOMMENDED OPERATING CONDITIONS

|           |                    |
|-----------|--------------------|
| $V_{DD}$  | = 0 V              |
| $V_{SS1}$ | = -4 to -15 V      |
| $V_{SS2}$ | = -4 to -15 V      |
| $V_{SS3}$ | = -4 to -15 V      |
| $f_c$     | = 36 kHz $\pm$ 10% |
| $T_A$     | = -25°C            |

## CONNECTION DIAGRAM

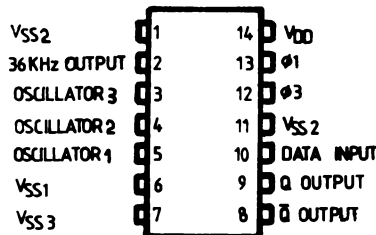

**ELECTRICAL CHARACTERISTICS**

| PARAMETER              | TEST CONDITIONS             | VALUES |      |           | UNIT       |
|------------------------|-----------------------------|--------|------|-----------|------------|
|                        |                             | min.   | typ. | max.      |            |
| Clock outputs          |                             |        |      |           |            |
| $t_r$ rise time        | 360 pF load                 | —      | 90   | 200       | ns         |
| $t_f$ fall time        | 360 pF load                 | —      | 120  | 250       | ns         |
| $t_w$ pulse width      | at 36 kHz                   | 10     | —    | —         | $\mu$ s    |
| $t_s$ pulse separation | at 36 kHz                   | 10     | —    | —         | $\mu$ s    |
| Stability              | with supply and temperature | —      | —    | $\pm 5\%$ |            |
| Output on-resistance   |                             |        |      |           |            |
| $\phi 1, \phi 3$       | VSS2 = -4 V                 | —      | 0.3  | 2         | k $\Omega$ |
| $Q, \bar{Q}$           | VSS3 = -4 V                 | —      | 200  | 750       | $\Omega$   |
| Supply current         |                             |        |      |           |            |
| ISS1                   | VSS1 = -4 V                 | —      | 130  | 200       | $\mu$ A    |
| ISS2                   | VSS2 = -15 V, 10 pF load    | —      | 100  | 200       | $\mu$ A    |
| ISS3                   | VSS3 = -15 V                | —      | 30   | 50        | $\mu$ A    |

**BLOCK DIAGRAM**

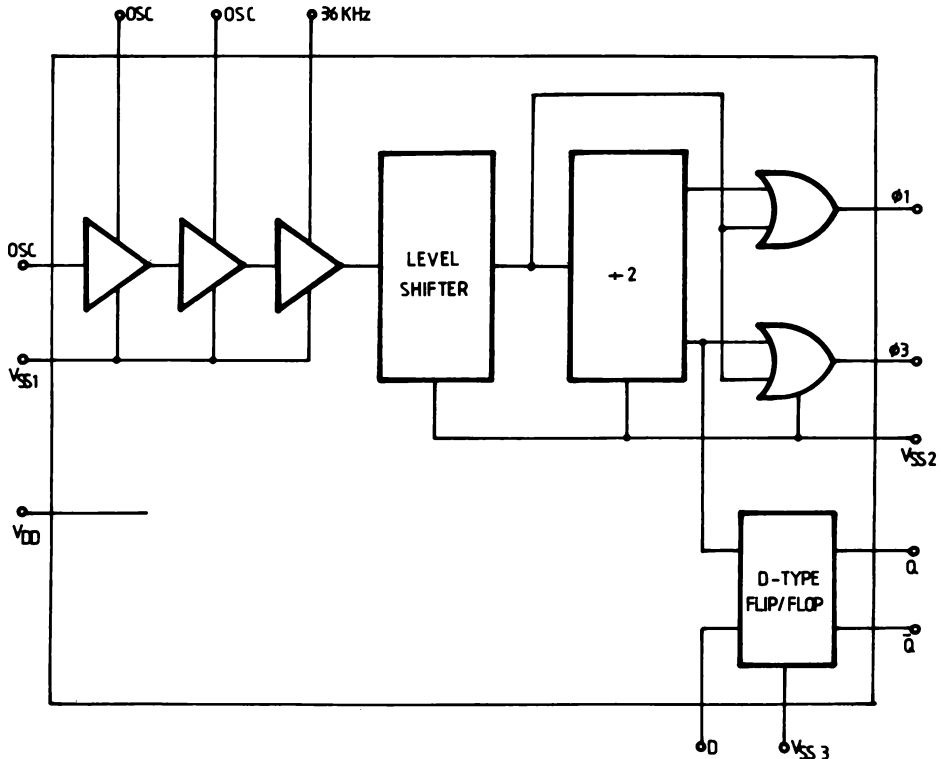

WAVEFORMS

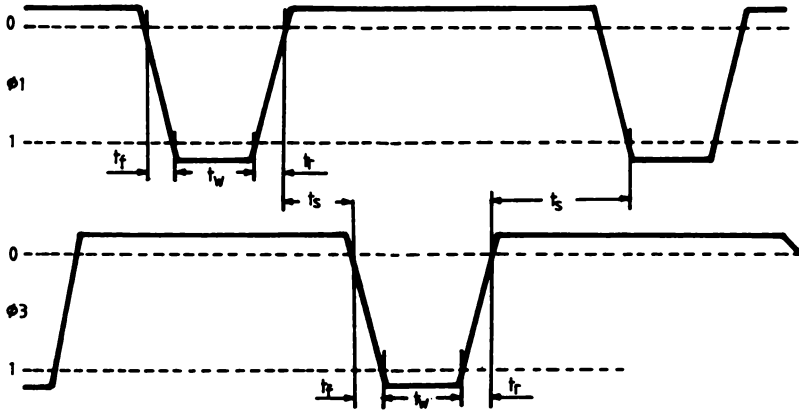

TYPICAL APPLICATIONS

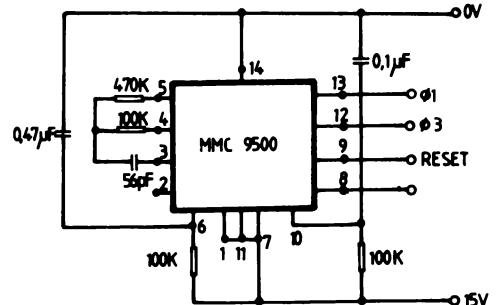
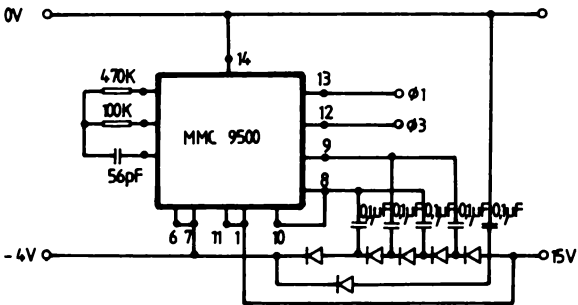

# 1024 BIT STATIC RANDOM-ACCESS MEMORY

## GENERAL DESCRIPTION

The MMN 2102 is a high speed 1024 word by 1 static N-channel silicon-gate MOS RAM. The device is fully static and therefore does not require clocks or refreshing to operate. The data is read out non destructively and has the same polarity as the input data.

## FEATURES

- Power supply  $V_{CC} = 5V$
- TTL compatible all inputs and outputs
- Three-state output
- Input protected against static charge
- Organization  $1024 \times 1$  bit in 16 pin std. package

## ABSOLUTE MAXIMUM RATINGS

|           |                                  |               |
|-----------|----------------------------------|---------------|
| $V_i$     | Input voltage (at any pin)       | -0.5 to 7 V   |
| $P_{tot}$ | Total power dissipation          | 1 W           |
| $T_{stg}$ | Storage temperature              | -33 to 125 °C |
| $T_{op}$  | Operating temperature under bias | 0 to 70 °C    |

All voltages are referred to GND pin voltage

## CONNECTION DIAGRAMS

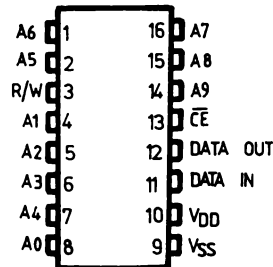

## TRUTH TABLE

| CE | R/W | $D_{IN}$ | $D_{OUT}$ | MODE         |
|----|-----|----------|-----------|--------------|
| H  | X   | X        | HIGH Z    | NOT SELECTED |
| L  | L   | L        | L         | WRITE "0"    |
| L  | L   | H        | H         | WRITE "1"    |
| L  | H   | X        | D         | READ         |



**STATIC ELECTRICAL CHARACTERISTICS**(V<sub>CC</sub> = 4.75V to 5.25V, T<sub>A</sub> = 0 to 70° C unless otherwise specified)

| PARAMETER                              | TEST CONDITIONS   | MMN 2102<br>MMN 2102-4 |      |                 | MMN 2102-2 |      |                 | MMN 2102-6 |      |                 | UNIT |
|--|---|------------------------|------|-----------------|------------|------|-----------------|------------|------|-----------------|------|
|  |   | min.                   | typ. | max.            | min.       | typ. | max.            | min.       | typ. | max.            |      |
| V <sub>IH</sub> Input high voltage     | $I_{OH} = -100\mu A$<br>$I_{OL} = 2.1\text{ mA}$<br>$V_I = 0V\text{ to }5.25\text{ V}$<br>$\overline{CE} = 2V, V_O = V_{OH}$<br>$\overline{CE} = 2V, V_O = 0.4\text{ V}$<br>$V_I = 5.25V,$<br>$T_A = 0^\circ\text{ C}$<br>$D_{OUT}\text{ open}$ | 2                      |      | V <sub>CC</sub> | 2          |      | V <sub>CC</sub> | 2.2        |      | V <sub>CC</sub> | V    |
| V <sub>IL</sub> Input low voltage      |   | -0.5                   |      | 0.8             | -0.5       |      | 0.8             | -0.5       |      | 0.65            | V    |
| V <sub>OH</sub> Output high voltage    |   | 2.4                    |      |                 | 2.4        |      |                 | 2.2        |      |                 | V    |
| V <sub>OL</sub> Output low voltage     |   |                        |      | 0.4             |            |      | 0.4             |            |      | 0.45            | V    |
| I <sub>I</sub> Input load current      |   |                        | 1    | 10              |            | 1    | 10              |            | 1    | 10              | μA   |
| I <sub>OH</sub> Output leakage current |   |                        | 1    | 5               |            | 1    | 5               |            | 1    | 5               | μA   |
| I <sub>OL</sub> Output leakage current |   |                        | -1   | -10             |            | -1   | -10             |            | -1   | -10             | μA   |
| I <sub>CC</sub> Supply current         |   |                        |      |                 |            |      |                 |            |      |                 | mA   |
|  |   |                        | 33   | 55              |            | 45   | 65              |            | 33   | 55              | mA   |

Note: typical values for T<sub>A</sub> = 25° C and nominal supply voltage**DYNAMIC ELECTRICAL CHARACTERISTICS**(T<sub>A</sub> = 0 to 70° C, V<sub>CC</sub> = 5 V unless otherwise specified)

| PARAMETER  | TEST CONDITIONS                               | MMN 2102-2 |      | MMN 2102 |      | MMN 2102-4 |      | MMN 2102-6 |      | UNIT |
|--|---|------------|------|----------|------|------------|------|------------|------|------|
|  |   | min.       | max. | min.     | max. | min.       | max. | min.       | max. |      |
| <b>Read Cycle</b>  |   |            |      |          |      |            |      |            |      |      |
| t <sub>RC</sub> Read cycle   |   | 250        |      | 350      |      | 450        |      | 650        |      | ns   |
| t <sub>ci</sub> Access time  |   |            | 250  |          | 350  |            | 450  |            | 650  | ns   |
| t <sub>fi</sub> CE to output time                                    |   |            | 130  |          | 180  |            | 230  |            | 400  | ns   |
| t <sub>OH1T</sub> Previous read data valid with respect to address   | t <sub>R</sub> t <sub>F</sub> = 10 ns         | 40         |      | 40       |      | 40         |      | 50         |      | ns   |
| t <sub>H2</sub> Previous read data valid with respect to chip enable | Load = 1 TTL gate and C <sub>L</sub> = 100 pF | 0          |      | 0        |      | 0          |      | 0          |      | ns   |
| <b>Write Cycle</b>   |   |            |      |          |      |            |      |            |      |      |
| t <sub>WC</sub> Write cycle Address to with                          |   | 250        |      | 350      |      | 450        |      | 650        |      | ns   |
| t <sub>AW</sub> setup time   | t <sub>R</sub> t <sub>F</sub> = 10 ns         | 20         |      | 20       |      | 20         |      | 200        |      | ns   |
| t <sub>WP</sub> Write pulse width                                    | Load = 1 TTL                                  | 180        |      | 250      |      | 300        |      | 400        |      | ns   |
| t <sub>WR</sub> Write recovery time                                  |   | 0          |      | 0        |      | 0          |      | 50         |      | ns   |
| t <sub>S</sub> Data setup time                                       | gate and C <sub>L</sub> = 100 pF              | 180        |      | 250      |      | 300        |      | 450        |      | ns   |
| t <sub>CW</sub> Chip enable to write Set up time                     |   | 180        |      | 250      |      | 300        |      | 550        |      | ns   |

**CAPACITANCE**(T<sub>A</sub> = 25° C, f = 1 Mhz)

| PARAMETER                         | TEST CONDITIONS      | VALUES |      |      | UNIT |
|-----------------------------------|----------------------|--------|------|------|------|
|                                   |                      | min.   | typ. | max. |      |
| C <sub>I</sub> Input capacitance  | V <sub>I</sub> = 0 V |        | 3    | 5    | pF   |
| C <sub>O</sub> Output capacitance | V <sub>O</sub> = 0 V |        | 7    | 10   | pF   |

**BLOCK DIAGRAM**

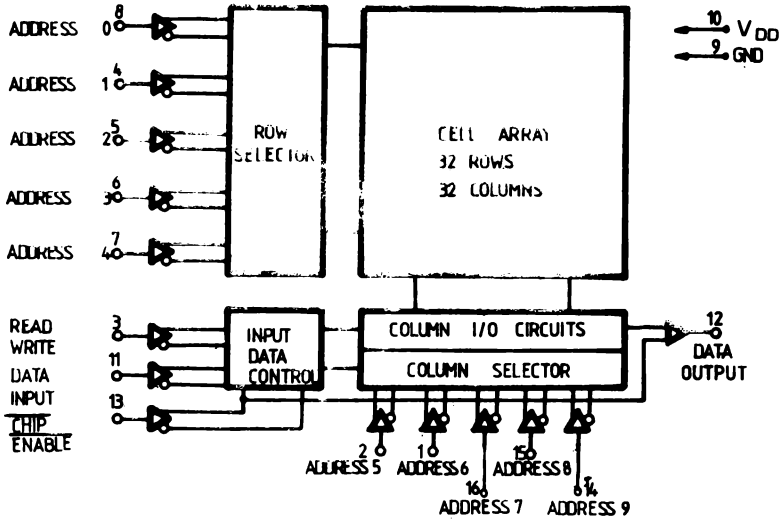

**WAVEFORMS**

**READ CYCLE**

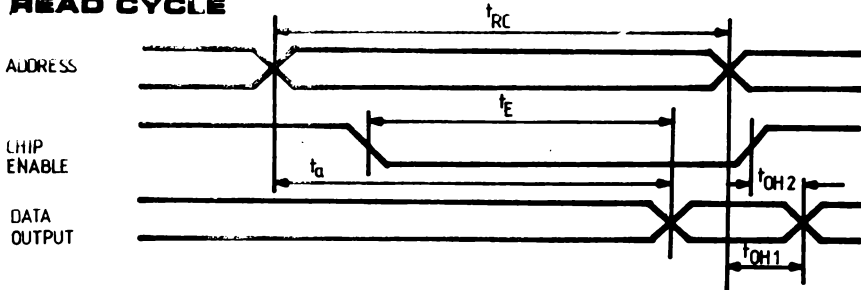

**WRITE CYCLE**

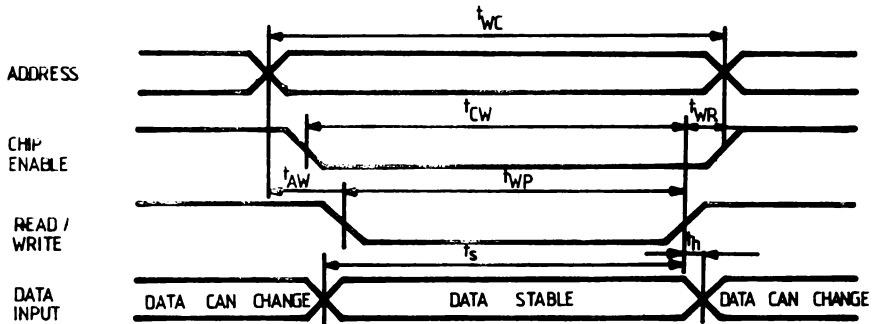

# 1024 × 4 BIT STATIC RAM

## GENERAL DESCRIPTION

MMN 2114 is a 4096-bit static Random Access Memory organized as 1024 words by 4-bits using a high performance MOS technology. It uses fully DC static circuitry throughout, in both array and decoding; therefore it requires no clocks or refreshing to operate. Data access is particularly simple since address setup times are not required. The data is read out nondestructively and has the same polarity as the input data.

Common input/output pins are provided. MMN 2114 is designed for memory applications where high performance and high reliability, low cost, large bit storage, and simple interfacing are important design objectives.

MMN 2114 is placed in an 18-pin package for the highest possible density. It is directly TTL compatible in all respects: inputs, outputs, a single +5 V supply.

A separate Chip Select (CS) lead allows easy selection of an individual package when outputs are oried.

## FEATURES

- single +5 V supply
- identical cycle and access times
- completely static memory — no clock or timing strobe required
- directly TTL compatible: all inputs and outputs
- common data input and output using three-state outputs
- high density 18 pin package

## ABSOLUTE MAXIMUM RATINGS

|           |   |           |       |
|-----------|---|-----------|-------|
| $T_A$     | Temperature under bias                    | -10°C to  | 80°C  |
| $T_{stg}$ | Storage Temperature                       | -65°C to  | 150°C |
| $V_i$     | Voltage on any Pin with Respect to ground | -0.5 V to | +7 V  |
| $P_{tot}$ | Power dissipation                         |           | 1.0W  |

## COMMENT

Stresses above those listed under "Absolute Maximum Ratings" may cause permanent damage to the device. This is a stress rating only and functional operation of the device at these or any other conditions above those indicated in the operational sections of this specification is not implied.

Exposure to absolute maximum rating conditions for extended periods may affect device reliability.

## PIN CONNECTIONS

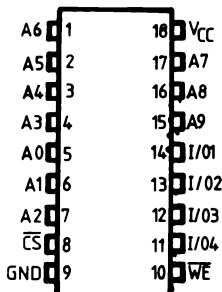

## PIN NAMES

|           |                   |                 |
|-----------|-------------------|-----------------|
| A0-A9     | ADDRESS INPUTS    | VCC POWER (+5V) |
| WE        | WRITE ENABLE      | GND GROUND      |
| CS        | CHIP SELECT       |                 |
| I/O1-I/O4 | DATA INPUT/OUTPUT |                 |

**D.C. CHARACTERISTICS**

T<sub>A</sub> = 0°C to +70°C, V<sub>CC</sub> = 5 V ± 5% (Unless otherwise specified)

| PARAMETER        | TEST CONDITIONS  | MMN 2114-2,<br>2114-3, 2114 |      | UNIT            |    |
|------------------|--|-----------------------------|------|-----------------|----|
|                  |  | min.                        | max. |                 |    |
| I <sub>I</sub>   | V <sub>IN</sub> = 0 to 5.25 V<br>CS = 2.4 V,<br>V <sub>I/O</sub> = 0.4 V to V <sub>CC</sub><br>V <sub>CC</sub> = 5.25 V, I <sub>I/O</sub> =<br>0 mA, T <sub>A</sub> = 25°C<br>V <sub>CC</sub> = 5.25 V, I <sub>I/O</sub> =<br>0 mA, T <sub>A</sub> = 0°C |                             | 10   | μA              |    |
| I <sub>Lo</sub>  |  |                             | 10   | μA              |    |
| I <sub>CC1</sub> |  |                             | 95   | mA              |    |
| I <sub>CC2</sub> |  |                             | 100  | mA              |    |
| V <sub>IL</sub>  |  |                             | -0.5 | 0.8             | V  |
| V <sub>IH</sub>  |  |                             | 2.0  | V <sub>CC</sub> | V  |
| I <sub>OL</sub>  |  | V <sub>OL</sub> = 0.4 V     | 2.1  | 6.0             | mA |
| I <sub>OH</sub>  |  | V <sub>OH</sub> = 2.4 V     | -1.0 | -1.4            | mA |

**A.C. CHARACTERISTICS**

(T<sub>A</sub> = 0°C to 70°C, V<sub>CC</sub> = 5 V ± 5% (Unless Otherwise Specified))

| PARAMETER          | 2114-2 |      | 2114-3 |      | 2114 |      | UNIT |
|--------------------|--------|------|--------|------|------|------|------|
|                    | min.   | max. | min.   | max. | min. | max. |      |
| <b>Read cycle</b>  |        |      |        |      |      |      |      |
| t <sub>RC</sub>    | 200    |      | 300    |      | 450  |      | ns   |
| t <sub>A</sub>     |        | 200  |        | 300  |      | 450  | ns   |
| t <sub>CO</sub>    |        | 70   |        | 100  |      | 120  | ns   |
| t <sub>CX</sub>    | 20     |      | 20     |      | 20   |      | ns   |
| t <sub>OTD</sub>   |        | 60   |        | 80   |      | 100  | ns   |
| t <sub>OHA</sub>   | 50     |      | 50     |      | 50   |      | ns   |
| <b>Write cycle</b> |        |      |        |      |      |      |      |
| t <sub>WC</sub>    | 200    |      | 300    |      | 450  |      | ns   |
| t <sub>W</sub>     | 120    |      | 150    |      | 200  |      | ns   |
| t <sub>WR</sub>    | 0      |      | 0      |      | 0    |      | ns   |
| t <sub>OTW</sub>   |        | 60   |        | 80   |      | 100  | ns   |
| t <sub>DW</sub>    | 120    |      | 150    |      | 200  |      | ns   |
| t <sub>DH</sub>    | 0      |      | 0      |      | 0    |      | ns   |

**CAPACITANCE**

T<sub>A</sub> = 25°C, f = 1.0 MHz

| PARAMETER        | typ | max | UNIT |
|------------------|-----|-----|------|
| C <sub>I/O</sub> |     | 5   | pF   |
| C <sub>IN</sub>  |     | 5   | pF   |

Note: This parameter is periodically sampled and not 100% tested.

## A.C. TEST CONDITIONS

|                            |                       |
|----------------------------|-----------------------|
| Input Pulse Levels         | 0.8 V to 2 V          |
| Input Rise and Fall Time   | 10 ns                 |
| Timing Measurement Levels: | Input<br>Output       |
|                            | 1.5 V                 |
|                            | 0.8 V and 2 V         |
| Output Load                | 1 TTL Gate and 100 pF |

## DATE STORAGE

When  $\overline{WE}$  is high, the data input buffers are inhibited to prevent erroneous data from being written into the array. As long as  $\overline{WE}$  remains high, the data stored cannot be affected by the Address, Chip Select, or Data I/O logic levels or timing transitions.

Data storage also cannot be affected by  $\overline{WE}$ , Addresses, or the I/O ports as long as CS is high. Either CS or  $\overline{WE}$  or both can prevent extraneous writing due to signal transitions.

Data within the array can only be changed during Write time—defined as the overlap of  $\overline{CS}$  low and  $\overline{WE}$  low. The addresses must be properly established during the entire Write time plus  $t_{WP}$ . Internal delays are such that address decoding propagates ahead of data inputs and therefore no address setup time is required. If the Write time precedes the addresses, the data in previously addressed locations, or some other location, may be changed. Addresses must remain stable for the entire Write cycle but the Data Inputs may change. The data which is stable for  $t_{DW}$  at the end of the Write time will be written into the addressed location.

## BLOCK DIAGRAM

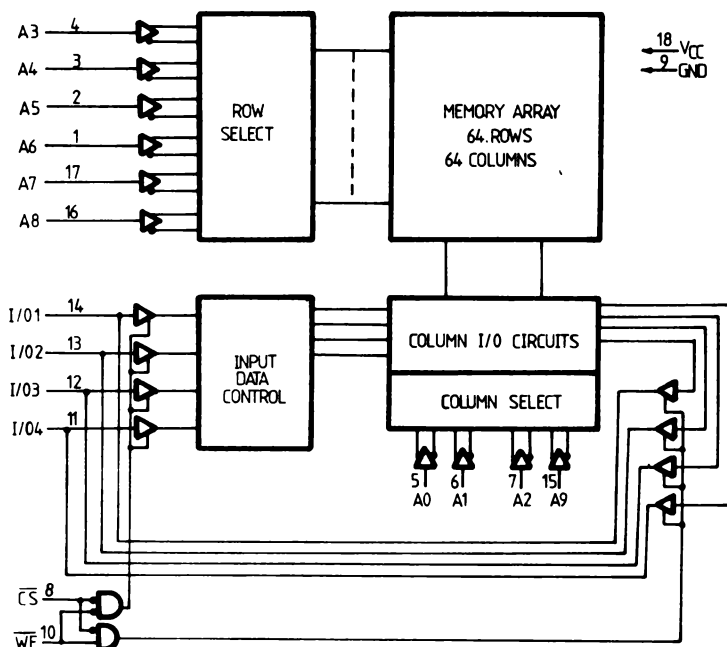

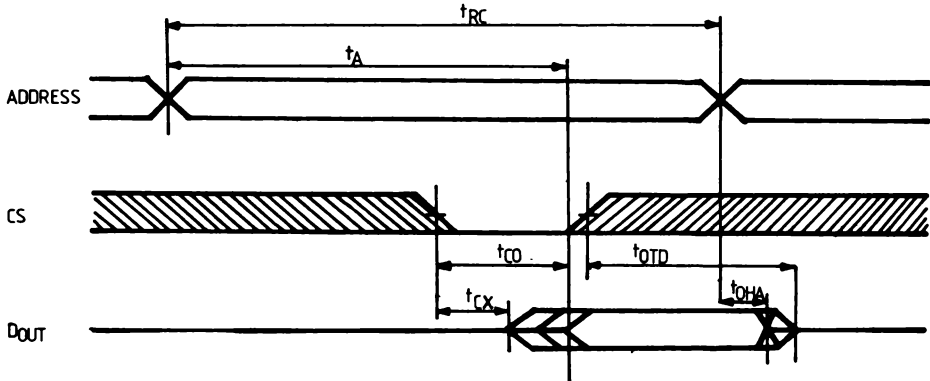
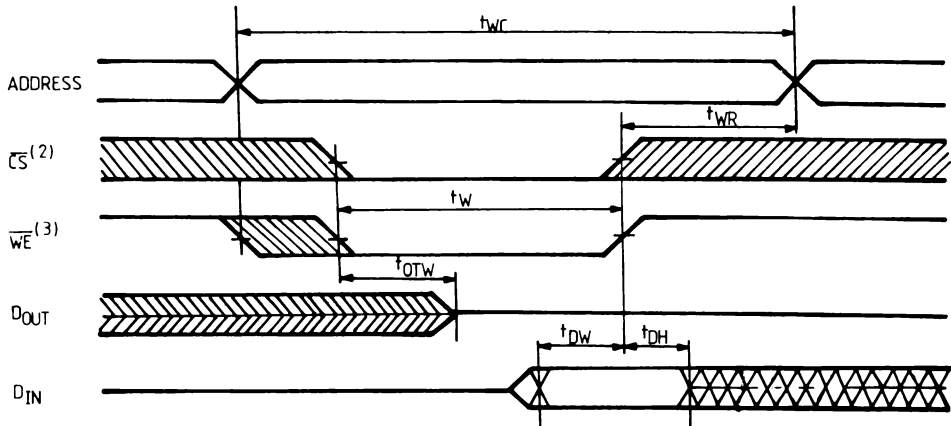
**WAVEFORMS****Read cycle (1)****Write cycle**

- Notes:
1.  $\overline{WE}$  is high for a Read cycle.
  2. If the  $\overline{CS}$  low transition occurs simultaneously with the  $\overline{WE}$  low transition, the output buffers remain in a high impedance state.
  3.  $\overline{WE}$  must be high during all address transitions.

# 4096 - BIT DYNAMIC RANDOM ACCESS MEMORY

## GENERAL DESCRIPTION

The MMN 4027 is a 4096 word by 1 bit dynamic N-channel silicon gate MOS RAM. The MMN 4027 uses a single transistor cell utilizing a dynamic storage technique and dynamic control circuitry with low power dissipation. A unique multiplexing and latching technique for the address inputs permits the MMN 4027 to be mounted in a standard 16-pin package. The MMN 4027 incorporates several flexible operating modes. In addition to the usual read and write cycles, read modify write, page mode and RAS-only refresh cycles are available with the MMN 4027. Page mode timing is very useful in systems requiring Direct Memory Access (DMA). The device is available in 16-lead dual in-line plastic or ceramic package (metal-seal), and ceramic package (frit-seal).

## FEATURES

- Power supply  $V_{DD} = 12\text{ V}$ ,  $V_{CC} = 5\text{ V}$ ,  $V_{BB} = -5\text{ V}$  (all with  $\pm 10\%$  tolerance)
- All inputs are low capacitance and TTL compatible
- Input latches for addresses, chip select and data in
- Inputs protected against static charge
- Three-state TTL compatible output
- Output data latched and valid into next cycle
- ECL compatible on  $V_{BB}$  power/supply (-5.7 V.)
- Low power consumption :

active power under 470 mW  
standby power under 27 mW

## ABSOLUTE MAXIMUM RATINGS\*

|           |   |         |      |    |
|-----------|---|---------|------|----|
|           | Voltage on any pin relative to $V_{BB}$             | -0.5 to | +20  | V  |
|           | Voltage on $V_{DD}$ , $V_{CC}$ relative to $V_{SS}$ | -1 to   | +15  | V  |
|           | $V_{BB} - V_{SS}$ ( $V_{DD} - V_{SS} > 0$ )         |         | 0    | V  |
| $T_A$     | Operating temperature                               | 0 to    | +70  | °C |
| $T_{stg}$ | Storage temperature for ceramic package             | -65 to  | +150 | °C |
|           | for plastic package                                 | -55 to  | +125 | °C |
| $I_o$     | Short circuit output current                        |         | 50   | mA |
| $P_{tot}$ | Total power dissipation                             |         | 1    | W  |

\* Stresses greater than those listed under "Absolute Maximum Ratings" may cause permanent damage to the device. This is a stress rating only and functional operation of the device at these or any other conditions above those indicated in the operating sections of this specification is not implied. Exposure to absolute maximum rating conditions for extended periods may affect device reliability.

## PIN CONNECTIONS

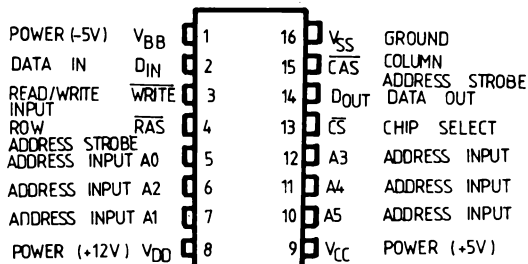

**BLOCK DIAGRAM**

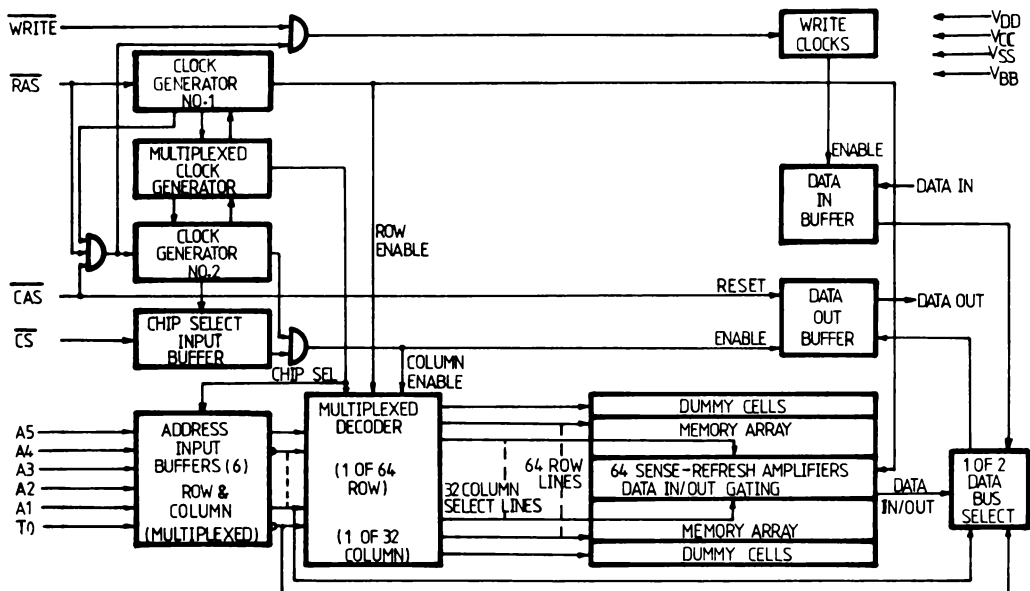

**RECOMMENDED DC OPERATING CONDITIONS**

( $T_A = 0$  to  $70^\circ\text{C}$ )

| PARAMETER  | VALUES |     |      | UNIT | NOTES |
|--|--------|-----|------|------|-------|
|  | min    | typ | max  |      |       |
| $V_{DD}$ Supply voltage  | 10.8   | 12  | 13.2 | V    | 2     |
| $V_{CC}$ Supply voltage  | 4.5    | 5   | 5.5  | V    | 2,3   |
| $V_{SS}$ Supply voltage  | 0      | 0   | 0    | V    | 2     |
| $V_{BB}$ Supply voltage  | -4.5   | -5  | -5.7 | V    | 2     |
| $V_{IHC}$ Input high voltage on $\overline{\text{RAS}}$ , $\overline{\text{CAS}}$ , $\overline{\text{WRITE}}$                | 2.4    |     | 7    | V    | 2     |
| $V_{IH}$ Input high voltage, all inputs except $\overline{\text{RAS}}$ , $\overline{\text{CAS}}$ , $\overline{\text{WRITE}}$ | 2.2    |     | 7    | V    | 2     |
| $V_{IL}$ Input low voltage, all inputs   | -1     |     | 0.8  | V    | 2     |

**DC ELECTRICAL CHARACTERISTICS**

( $T_A = 0$  to  $70^\circ\text{C}$ ) ( $V_{DD} = 12\text{V} \pm 10\%$ ) ( $V_{CC} = 5\text{V} \pm 10\%$ ,  $V_{SS} = 0\text{V}$ ,  $V_{BB} = -5.7$  to  $-4.5\text{V}$ )

| PARAMETER  | VALUES |      |      | UNIT          | NOTES |
|--|--------|------|------|---------------|-------|
|  | min.   | typ. | max. |               |       |
| $I_{DD1}$ Average $V_{DD}$ power supply current                          |        |      | 35   | mA            | 5     |
| $I_{DD2}$ Standby $V_{DD}$ power supply current                          |        |      | 2    | mA            | 8     |
| $I_{DD3}$ Average $V_{DD}$ power supply current during „RAS only“ cycles |        |      | 25   | mA            |       |
| $I_{CC}$ $V_{CC}$ power supply current                                   |        |      |      | mA            | 6     |
| $I_{BB}$ Average $V_{BB}$ power supply current                           |        |      | 150  | $\mu\text{A}$ |       |
| $I_{IL}$ Input leakage current (any input)                               |        |      | 10   | $\mu\text{A}$ | 7     |
| $I_{OL}$ Output leakage current  |        |      | 10   | $\mu\text{A}$ | 8,9   |
| $V_{OH}$ Output high voltage ( $I_{SOURCE} = -5\text{mA}$ )              | 2.4    |      |      | V             |       |
| $V_{OL}$ Output low voltage ( $I_{SINK} = 3.2\text{mA}$ )                |        |      | 0.4  | V             |       |



**AC CHARACTERISTICS AND RECOMMENDED OPERATING CONDITIONS**

(T<sub>A</sub> = 0 to 70°C) (V<sub>DD</sub> = 12V ± 10%) (V<sub>CC</sub> = 5V ± 10%, V<sub>SS</sub> = 0V, V<sub>BB</sub> = -5.7 to -4.5V)

| PARAMETER  | TYPES      |       |            |       |            |       | UNIT | NOTE  |
|--|------------|-------|------------|-------|------------|-------|------|-------|
|  | MMN 4027-2 |       | MMN 4027-3 |       | MMN 4027-4 |       |      |       |
|  | min.       | max.  | min.       | max.  | min.       | max.  |      |       |
| t <sub>RC</sub> Random read or write cycle time            | 320        |       | 375        |       | 380        |       | ns   |       |
| t <sub>RWC</sub> Read write cycle time                     | 320        |       | 375        |       | 395        |       | ns   |       |
| t <sub>RMW</sub> Read modify write cycle time              | 320        |       | 405        |       | 470        |       | ns   |       |
| t <sub>RAC</sub> Access time from row address strobe       |            | 150   |            | 200   |            | 250   | ns   | 11-13 |
| t <sub>CAC</sub> Access time from column address strobe    |            | 100   |            | 135   |            | 165   | ns   | 12-13 |
| t <sub>OFF</sub> Output buffer turn-off delay              |            | 40    |            | 50    |            | 60    | ns   |       |
| t <sub>RP</sub> Row address strobe precharge time          | 100        |       | 120        |       | 120        |       | ns   |       |
| t <sub>RAS</sub> Row address strobe pulse width            | 150        | 10000 | 200        | 10000 | 250        | 10000 | ns   |       |
| t <sub>RSH</sub> Row address strobe hold time              | 100        |       | 135        |       | 165        |       | ns   |       |
| t <sub>CAS</sub> Column address strobe pulse width         | 100        |       | 135        |       | 165        |       | ns   |       |
| t <sub>CSH</sub> Column address strobe hold time           | 150        |       | 200        |       | 250        |       | ns   |       |
| t <sub>RCD</sub> Row to column strobe delay                | 20         | 50    | 25         | 65    | 35         | 85    | ns   | 14    |
| t <sub>ASR</sub> Row address set-up time                   | 0          |       | 0          |       | 0          |       | ns   |       |
| t <sub>RAH</sub> Row address hold time                     | 20         |       | 25         |       | 35         |       | ns   |       |
| t <sub>ASC</sub> Column address set-up time                | -10        |       | -10        |       | -10        |       | ns   |       |
| t <sub>CAH</sub> Column address hold time                  | 45         |       | 55         |       | 75         |       | ns   |       |
| t <sub>AR</sub> Column address hold time referenced to RAS | 95         |       | 120        |       | 160        |       | ns   |       |
| t <sub>CSC</sub> Chip select set-up time                   | -10        |       | -10        |       | -10        |       | ns   |       |
| t <sub>CH</sub> Chip select hold time                      | 45         |       | 55         |       | 75         |       | ns   |       |
| t <sub>CHR</sub> Chip select hold time referenced to RAS   | 95         |       | 120        |       | 160        |       | ns   |       |
| t <sub>T</sub> Transition time (rise and fall)             | 3          | 35    | 5          | 50    | 5          | 50    | ns   | 15    |
| t <sub>RCS</sub> Read command set-up time                  | 0          |       | 0          |       | 0          |       | ns   |       |
| t <sub>RCH</sub> Read command hold time                    | 0          |       | 0          |       | 0          |       | ns   |       |
| t <sub>WCH</sub> Write command hold time                   | 45         |       | 55         |       | 75         |       | ns   |       |
| t <sub>WCR</sub> Write command hold time referenced to RAS | 95         |       | 120        |       | 160        |       | ns   |       |
| t <sub>WP</sub> Write command pulse width                  | 45         |       | 55         |       | 75         |       | ns   |       |
| t <sub>RWL</sub> Write command to row strobe lead time     | 50         |       | 70         |       | 85         |       | ns   |       |
| t <sub>CWL</sub> Write command to column strobe lead time  | 50         |       | 70         |       | 85         |       | ns   |       |
| t <sub>DS</sub> Data in set-up time                        | 0          |       | 0          |       | 0          |       | ns   | 16    |
| t <sub>DH</sub> Data in hold-time                          | 45         |       | 55         |       | 75         |       | ns   | 16    |
| t <sub>DHR</sub> Data in hold time referenced to RAS       | 95         |       | 120        |       | 160        |       | ns   |       |
| t <sub>CRP</sub> Column to row strobe precharge time       | 0          |       | 0          |       | 0          |       | ns   |       |
| t <sub>CP</sub> Column precharge time                      | 60         |       | 80         |       | 110        |       | ns   |       |
| t <sub>RFSSH</sub> Refresh period                          |            | 2     |            | 2     |            | 2     | ns   |       |
| t <sub>WCS</sub> Write command set-up time                 | 0          |       | 0          |       | 0          |       | ns   | 17    |
| t <sub>CWD</sub> CAS to WRITE delay                        | 60         |       | 80         |       | 90         |       | ns   | 17    |
| t <sub>RWD</sub> RAS to WRITE delay                        | 110        |       | 145        |       | 175        |       | ns   | 17    |
| t <sub>DOH</sub> Data out hold time                        | 10         |       | 10         |       | 10         |       | ns   |       |

**CAPACITANCES**

(T<sub>A</sub> = 0 to 70°C, V<sub>DD</sub> = 12V ± 10%, V<sub>SS</sub> = 0V, V<sub>BB</sub> = -5.7 to -4.5V)

| PARAMETER   | VALUES |      | UNIT | NOTES |
|---|--------|------|------|-------|
|   | typ.   | max. |      |       |
| C <sub>I1</sub> Input capacitance (A <sub>0</sub> -A <sub>5</sub> , D <sub>IN</sub> , $\overline{CS}$ ) | 4      | 5    | pF   | 18    |
| C <sub>I2</sub> Input capacitance (RAS, CAS, WRITE)   | 8      | 10   | pF   | 18    |
| C <sub>O</sub> Output capacitance (O <sub>UT</sub> )  | 5      | 7    | pF   | 8-18  |

## NOTES

1. Several cycles are required after power-up before proper device operation is achieved. Any 8 cycles which perform refresh are adequate for this purpose.
2. All voltages referenced to  $V_{SS}$ .  $V_{BB}$  must be applied before and removed after other supply voltages.
3. Output voltage will swing from  $V_{SS}$  to  $V_{CC}$  when enabled, with no output load. For purposes of maintaining data in standby mode,  $V_{CC}$  may be reduced to  $V_{SS}$  without affecting refresh operations or data retention. However, the  $V_{OH}$  (min) specification is not guaranteed in this mode.
4.  $T_{amb}$  is specified for operation at frequencies to  $t_{RC} \geq t_{RC}(\text{min})$ . Operation at higher cycle rates with reduced ambient temperatures and higher power dissipation is permissible provided that all AC parameters are met.
5. Current is proportional to cycle rate.  $I_{DD1}$  (max) is measured at the cycle rate specified by  $t_{RC}(\text{min})$ .
6.  $I_{CC}$  depends on output loading. The  $V_{CC}$  supply is connected to the output buffer only.
7. All device pins at 0 volts except  $V_{BB}$  which is at -5V and the pin under test which is at +10V.
8. Output is disabled (high-impedance) and  $\overline{\text{RAS}}$  and  $\overline{\text{CAS}}$  are both at a logic 1. Transient stabilization is required prior to measurement of this parameter.
9.  $0V \leq V_{out} \leq +10V$ .
10. AC measurement assume  $t_T = 5\text{ns}$ .
11. Assumes that  $t_{RCD} \leq t_{RCD}(\text{max})$ .
12. Assumes that  $t_{RCD} \geq t_{RCD}(\text{max})$ .
13. Measured with a load circuit equivalent to 2TTL loads and 100 pF.
14. Operation within the  $t_{RCD}(\text{max})$  limit insures that  $t_{RAC}(\text{max})$  can be met.  $t_{RCD}(\text{max})$  is specified as a reference point only; if  $t_{RCD}$  is greater than the specified  $t_{RCD}(\text{max})$  limit, then access time is controlled exclusively by  $t_{CAC}$ .
15.  $V_{IHC}$  (min) or  $V_{IH}(\text{min})$  and  $V_{IL}(\text{max})$  are reference levels for measuring timing of input signals. Also, transition times are measured between  $V_{IHC}$  or  $V_{IH}$  and  $V_{IL}$ .
16. These parameters are referenced to  $\overline{\text{CAS}}$  leading edge in random write cycles and to  $\overline{\text{WRITE}}$  leading edge in delayed write or read-modify-write cycles.
17.  $t_{WCS}$ ,  $t_{CWD}$  and  $t_{RWD}$  are restrictive operating parameters in a read/write or read/modify/write cycle only. If  $t_{WCS} \geq t_{WCS}(\text{min})$ , the cycle is an early write cycle and Data Out will contain the data written into the selected cell. If  $t_{CWD} \geq t_{CWD}(\text{min})$  and  $t_{RWD} \geq t_{RWD}(\text{min})$ , the cycle is a read-write cycle and Data Out will contain data read from the selected, cell. If neither of the above sets of conditions is satisfied, the condition of Data Out (at access time) is indeterminate.
18. Effective capacitance is calculated from the equation :

$$C = \frac{\Delta Q}{\Delta V} \text{ with } \Delta V = 3 \text{ volts.}$$

## ADDRESSING

The 12 address bits required to decode one of 4096 cell locations within the M 4027 are multiplexed onto the 6 address inputs and latched into the on-chip row and column address latches.

Row Address Strobe ( $\overline{\text{RAS}}$ ) latches the six row address bits onto the chip. Column Address Strobe ( $\overline{\text{CAS}}$ ) latches the six column address bits plus Chip Select ( $\overline{\text{CS}}$ ) onto the chip.

Since the internal circuitry allows the column information to be externally applied to the chip before it is actually required, the hold time requirements for column address and  $\overline{\text{CS}}$  are also referenced to  $\overline{\text{RAS}}$ . However, this gates  $\overline{\text{CAS}}$  feature allows the systems designer to compensate for timing skews that may be encountered in the multiplexing operation.

Since the Chip Select signal is not required until  $\overline{\text{CAS}}$  time, which is well into the memory cycle, its decoding time does not add to system access or cycle time.

Additional timing margin is gained because column address is not required until  $\overline{\text{CAS}}$  makes its negative transition.

The timing is further simplified by the positive transition of  $\overline{\text{CAS}}$  not being referenced to the positive transition of  $\overline{\text{RAS}}$ . In fact,  $\overline{\text{CAS}}$  need not go HIGH until the beginning of the next cycle.

## DATA INPUT/OUTPUT

Data to be written into selected storage cell of the memory chip is first stored in the on-chip data latch. The gating of this latch is performed with a combination of  $\overline{\text{WRITE}}$  and  $\overline{\text{CAS}}$  while  $\overline{\text{RAS}}$  is active.

The later of this signals ( $\overline{\text{WRITE}}$  or  $\overline{\text{CAS}}$ ) to make its negative transition is the strobe for the Data In into the latch. This permits several options in the write cycle timing. In a write cycle, if the  $\overline{\text{WRITE}}$  input is activated prior to  $\overline{\text{CAS}}$ , the Data In is strobe by  $\overline{\text{CAS}}$ , and set-up time and hold time are referenced to  $\overline{\text{CAS}}$ . If the Data In input is not available at  $\overline{\text{CAS}}$  time or the cycle is a read-write or readmodify-write, the  $\overline{\text{WRITE}}$  signal must be delayed until after  $\overline{\text{CAS}}$ . In this "delayed write cycle" the data input set-up and hold times are referenced to the negative edge of  $\overline{\text{WRITE}}$  rather than to  $\overline{\text{CAS}}$ . (To illustrate this feature, Data In is re-

referenced to  $\overline{\text{WRITE}}$  in the timing diagram depicting the read-write and page mode write cycles while the "early write" cycle diagram shows Data in referenced to  $\overline{\text{CAS}}$ . Note that if the chip is unselected ( $\overline{\text{CS}}$  high at  $\overline{\text{CAS}}$  time)  $\overline{\text{WRITE}}$  commands are not executed and, consequently, data stored in the memory is unaffected. Data is retrieved from the memory in read cycle by maintaining  $\overline{\text{WRITE}}$  in the inactive or high state throughout the portion of memory cycle in which  $\overline{\text{CAS}}$  is active. Data read from the selected cell will be available at the output within the specified access time.

## DATA OUTPUT CONTROL

At the beginning of a memory cycle, the state of the Data Out latch and buffer depend on the previous memory cycle.

Changes in the condition of Data Out latch are initiated by  $\overline{\text{CAS}}$ . The negative transition of  $\overline{\text{CAS}}$  causes the Data Output ( $D_{\text{OUT}}$ ) to unconditionally go to its open-circuit state. It will remain open-circuited until after the access  $D_{\text{OUT}}$  time, then it will assume the proper state for the type of cycle performed.

If the cycle is read, read-modify-write, or a delayed write and the chip is selected, then the  $D_{\text{OUT}}$  latch and buffer will contain the data from the selected cell. This output data is the same polarity (not inverted) as the input data. If the cycle is a write cycle ( $\overline{\text{WRITE}}$  active low before  $\overline{\text{CAS}}$  goes low) and the chip is selected, then  $D_{\text{OUT}}$  will contain the input data.

Once the  $D_{\text{OUT}}$  goes active, it will remain active until the next negative transition of  $\overline{\text{CAS}}$ .

If the cycle is a  $\overline{\text{CAS}}$  only cycle (no  $\overline{\text{RAS}}$  signal), then  $D_{\text{OUT}}$  will assume the open circuit state.

The same is true for normal cycles (both  $\overline{\text{RAS}}$  and  $\overline{\text{CAS}}$  present when the chip is unselected  $D_{\text{OUT}}$  remains in the open-circuit state until the next negative transition of  $\overline{\text{CAS}}$ .

$\overline{\text{RAS}}$  only refresh cycles (no  $\overline{\text{CAS}}$ ) have no effect on the  $D_{\text{OUT}}$ .

However, when  $\overline{\text{RAS}}$  only refresh cycles are continued for extended periods of time,  $D_{\text{OUT}}$  may eventually go open-circuit.

If the chip unselected, it will not accept a write command and the  $D_{\text{OUT}}$  will remain in the open-circuit state.

## INPUT/OUTPUT LEVELS

All inputs, including the two address strobes, interface directly with TTL.

The high-impedance, low-capacitance input characteristics simplify input driver selection by allowing use of standard logic elements rather than specially designed driver elements.

The 3-state output buffer is a low impedance to  $V_{\text{CC}}$  for a logic "1" and a low impedance to  $V_{\text{SS}}$  for a logic "0".

The output resistance to  $V_{\text{CC}}$  (logic "1" state) is 420 ohm maximum and 135 ohm typically.

The output resistance to  $V_{\text{SS}}$  (logic "0" state) is 125 ohm maximum and 35 ohm typically.

The separate  $V_{\text{CC}}$  pin allows the output buffer to be powered from supply voltage of the logic to which chip is interfaced.

During battery stand-by operation, the  $V_{\text{CC}}$  pin may be unpowered without effecting the MMN 4027 refresh operation.

This allows all system logic, except  $\overline{\text{RAS}}$  timing circuitry and refresh address logic, to be turned off during battery stand-by to save power.

## REFRESH

Refresh of the dynamic cell matrix is accomplished by performing a memory cycle at each of the 64 row address every two millisecond or less.

Any cycle in which a  $\overline{\text{RAS}}$  signal occurs, accomplished a refresh operation. A read cycle will refresh the selected row, regardless of the state of the Chip Select ( $\overline{\text{CS}}$ ) input.

A write or read-modify-write cycle also refreshes the selected row, but the chip should be unselected to prevent writing data into the selected cell.

If, during a refresh cycle, the MMN 4027 receives a  $\overline{\text{RAS}}$  signal but no  $\overline{\text{CAS}}$  signal, the state of the output will not be affected. However, if " $\overline{\text{RAS}}$ -only" refresh cycles (when  $\overline{\text{RAS}}$  is the only signal applied to the chip) are contained for extended periods, the output buffer may eventually lose proper data and go open-circuit.

The output buffer will regain activity with the first cycle in which a  $\overline{\text{CAS}}$  signal is applied to the chip.

## POWER DISSIPATION/STANDBY MODE

Most of the circuitry used in the MMN 4027 and most of the power drawn is the result of an address strobe edge. Because the power is not drawn during the time the strobe is active, the dynamic power is a function of operating frequency rather than active duty cycle.

Typically, the power is 170 mW at 1  $\mu\text{sec}$  cycle rate for MMN 4027 with a worse case power of less than 470 mW at 320  $\mu\text{sec}$  cycle time.

To reduce the overall system power, the Row Address Strobe ( $\overline{RAS}$ ) should be decoded and supplied to only the selected chips.

The  $\overline{CAS}$  must be supplied to all chips (to turn off the unselected output.).

Those chips that did not receive a  $\overline{RAS}$ , however will not dissipate any power on the  $\overline{CAS}$  edges, except for that required to turn off the outputs.

If the  $\overline{RAS}$  signal is decoded and supplied only the selected chips, then the chip select ( $\overline{CS}$ ) input of all chips can be at a logic 0.

Then chips that receive a  $\overline{CAS}$  but no  $\overline{RAS}$  will be unselected (output open-circuited) regardless of the Chip Select input.

For refresh cycles, however, either the  $\overline{CS}$  input for all chips must be high or the  $\overline{CAS}$  input must be held high to prevent several "wire-OR" outputs from turning on with opposing force. Note that the MMN 4027 will dissipate considerably less power when the refresh operation is accomplished with a "RAS-only" cycle as opposed to a normal  $\overline{RAS}/\overline{CAS}$  memory cycle.

### PAGE MODE OPERATION

The "Page mode" feature of the MMN 4027 allows for successive memory operations at multiple column location of the same row address with increased speed without an increase in power. This is done by strobing the row address into the chip and keeping the  $\overline{RAS}$  signal at logic 0 throughout all successive memory cycles in which the row address is common.

This "Page Mode" of operation will not dissipate the power associated with the negative going edge of  $\overline{RAS}$ . The time required for strobing in a new row address is eliminated thereby decreasing the access and cycle times. The chip select input ( $\overline{CS}$ ) is operative in page mode cycles just as in normal cycles. It is not necessary that the chip be selected during the first operation in sequence of page cycles.

Likewise, the  $\overline{CS}$  input can be used to select or disable any cycle (s) in a series of page cycles. This feature allows the page boundary to be extended beyond the 64 column location in a single chip.

The page boundary can be extended by applying  $\overline{RAS}$  to multiple 4K memory blocks and decoding  $\overline{CS}$  to select the proper block.

### POWER UP

The MMN 4027 requires no particular power supply sequencing so long as the Absolute Maximum Rating Conditions are observed. However, in order to insure compliance with the Absolute Maximum Ratings, Microelectronica recommends sequencing of power supplies such that  $V_{BB}$  is applied first and removed last.  $V_{BB}$  should never be more positive than  $V_{SS}$  when power is applied to  $V_{DD}$ .

Under system failure condition in which one or more supplied exceed the specified limits significant additional margin against catastrophic device failure may be achieved by forcing  $\overline{RAS}$  and Data Out to the inactive state. After power is applied to the device, the MMN 4027 requires several cycles before proper device operation is achieved.

Any 8 cycles which perform refresh are adequate for this purpose.

### READ CYCLE

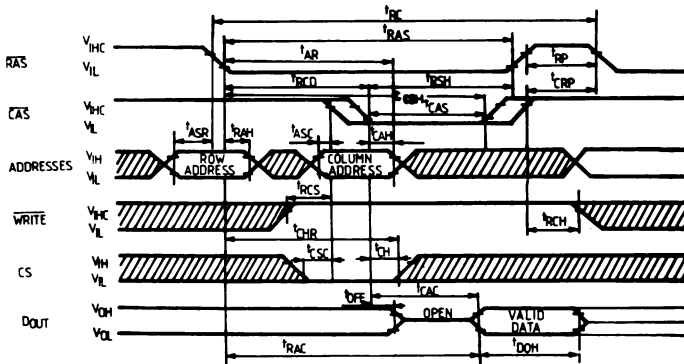

**WRITE CYCLE  
(early write)**

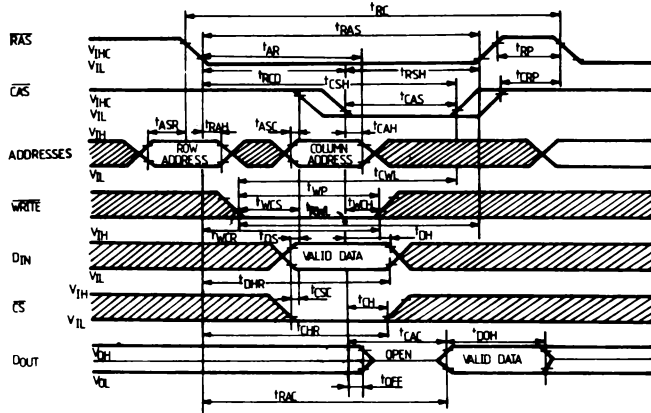

**READ WRITE / READ MODIFY-WRITE CYCLE**

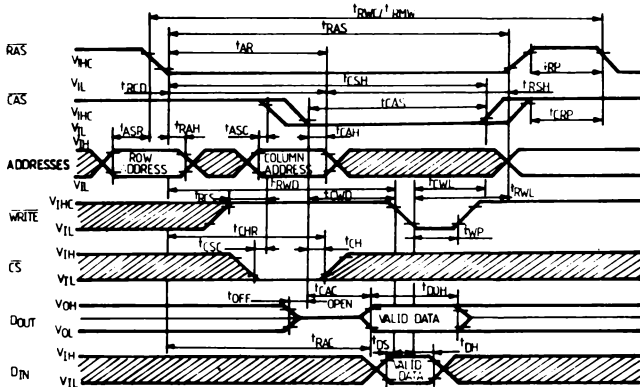

**RAS ONLY REFRESH CYCLE**

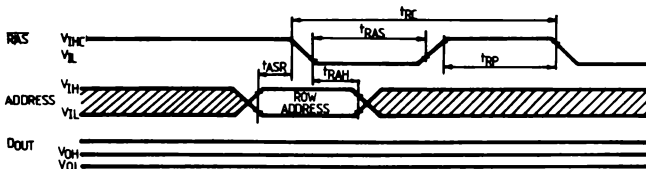

PAGE MODE READ CYCLE

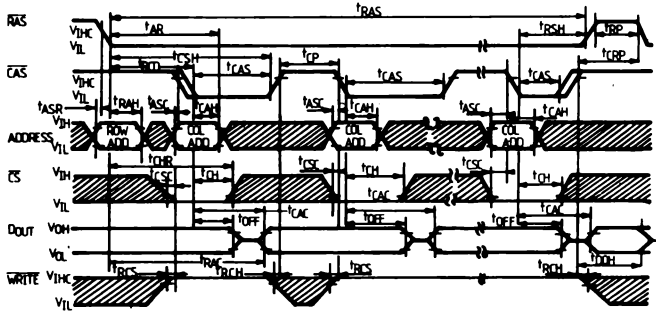

PAGE MODE WRITE CYCLE

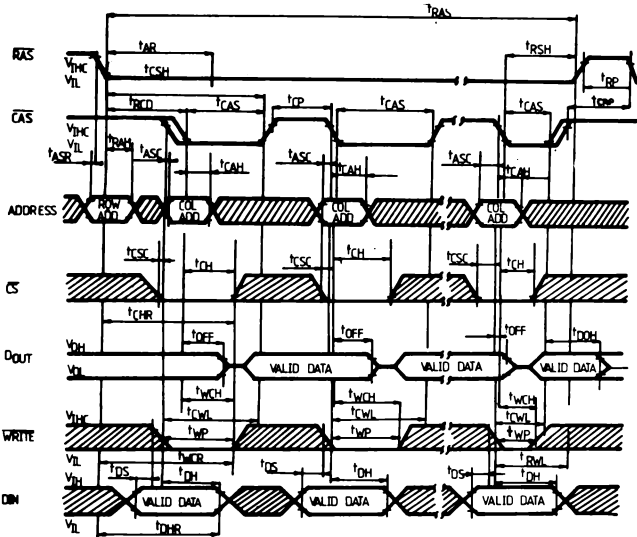

# 16384-BIT DYNAMIC RANDOM ACCESS MEMORY

## GENERAL DESCRIPTION

The MMN 4116 is a MOS dynamic random access memory circuit organized as 16384 words by 1 bit. The technology used to fabricate the MMN 4116 is double-poly N-channel silicon gate.

This process, coupled with the use of a single transistor dynamic storage cell, provides the maximum possible circuit density and reliability.

Multiplexed address inputs permit the MMN 4116 to be packaged in a standard 16-pin DIP.

## FEATURES

- $\pm 10\%$  tolerance on all power supplies (+12 V,  $\pm 5$  V)
- low power: 462 mW active, 20 mW standby (max)
- all inputs TTL compatible and protected against static charge.
- ECL compatible on  $V_{BB}$  power supply (-5-7 V)
- 128 refresh cycles
- read-modify-write, RAS-only refresh, and page-mode capability
- output data controlled by CAS and unlatched at end of cycle to allow two dimensional chip selection and extended page boundary

## ABSOLUTE MAXIMUM RATINGS

|           |  |        |    |        |
|-----------|--|--------|----|--------|
|           | Voltage on any pin relative to $V_{BB}$                      | -0.5 V | to | +20 V  |
|           | Voltage on $V_{DD}$ , $V_{CC}$ supplies relative to $V_{SS}$ | -1 V   | to | +15 V  |
|           | $V_{BB} - V_{SS}$ ( $V_{DD} - V_{SS} > 0$ )                  |        |    | 0 V    |
| $T_A$     | Operating temperature  | 0°C    | to | +70°C  |
| $T_{stg}$ | Storage temperature  | -55°C  | to | +125°C |
| $I_o$     | Short circuit output current                                 |        |    | 50 mA  |
| $P_{tot}$ | Total power dissipation                                      |        |    | 1 W    |

## RECOMMENDED DC OPERATING CONDITIONS

( $T_A = 0$  to 70°C)<sup>1</sup>

|   |                  |          |
|---|------------------|----------|
| $V_{DD}$ supply voltage                               | 12 V $\pm 10\%$  | Note 2   |
| $V_{CC}$ supply voltage                               | 5 V $\pm 10\%$   | Note 2,3 |
| $V_{SS}$ supply voltage                               | 0 V              | Note 2   |
| $V_{BB}$ supply voltage                               | -5.7 V to -4.5 V | Note 2   |
| Input high voltage on RAS, CAS, WRITE                 | 2.7 V to 7 V     | Note 2   |
| Input high voltage, all inputs except RAS, CAS, WRITE | 2.4 V to 7 V     | Note 2   |
| Input low voltage, all inputs                         | -1 V to 0.8 V    | Note 2   |

## PIN CONNECTIONS

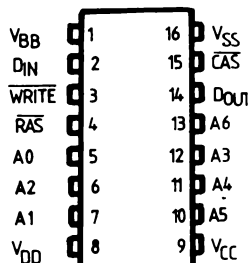

## PIN NAMES

|             |                       |
|-------------|-----------------------|
| $A_0 - A_6$ | ADDRESS INPUTS        |
| CAS         | COLUMN ADDRESS STROBE |
| DIN         | DATA IN               |
| $D_{OUT}$   | DATA OUT              |
| RAS         | ROW ADDRESS STROBE    |
| WRITE       | READ/WRITE INPUT      |
| $V_{BB}$    | POWER (-5 V)          |
| $V_{CC}$    | POWER (+5 V)          |
| $V_{DD}$    | POWER (+12 V)         |
| $V_{SS}$    | GROUND                |

**BLOCK DIAGRAM**

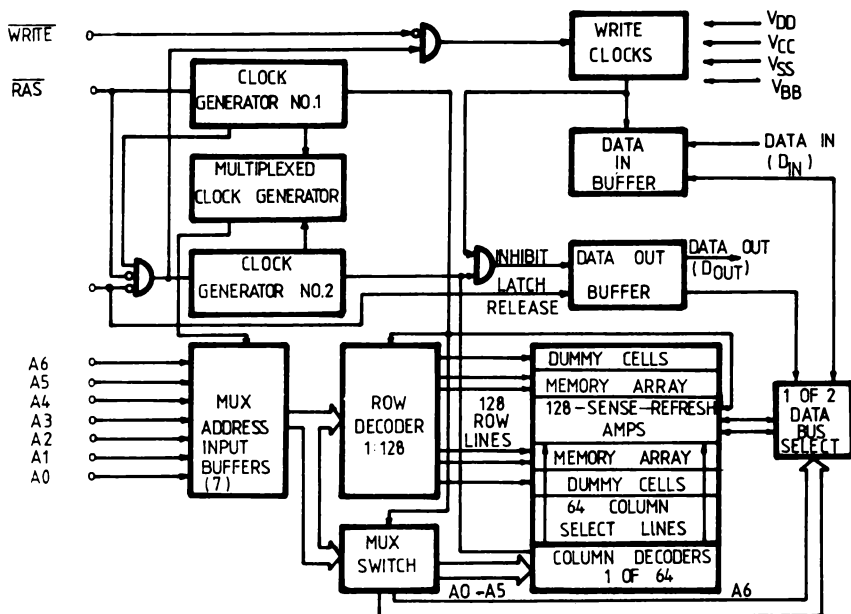

**DC ELECTRICAL CHARACTERISTICS**

( $T_A = 0$  to  $70^\circ\text{C}$ ,  $V_{DD} = 12\text{V} \pm 10\%$ ;  $V_{BB} = -5.7$  to  $-4.5\text{V}$ ;  $V_{SS} = 0\text{V}$ ;  $V_{CC} = 5\text{V} \pm 10\%$ )

| PARAMETER                           | TEST CONDITIONS  | MMN 4116-2/3 |     | MMN 4116-4 |     | UNIT          | NOTE |
|-------------------------------------|--|--------------|-----|------------|-----|---------------|------|
|                                     |  | min          | max | min        | max |               |      |
| $I_{DD1}$ Average operating current | RAS, CAS cycling   |              | 35  |            | 35  | mA            | 4    |
| $I_{CC1}$ Average operating current |  |              |     |            |     |               | 5    |
| $I_{BB1}$ Average operating current | $t_{RC} = t_{RC}(\text{min})$  |              | 200 |            | 200 | $\mu\text{A}$ |      |
| $I_{DD2}$ Standby current           | RAS = $V_{IH(C)}$  |              | 1.5 |            | 1.5 | mA            |      |
| $I_{CC2}$ Standby current           | $D_{OUT} = \text{High impedance}$  | -10          | 10  | -10        | 10  | $\mu\text{A}$ |      |
| $I_{BB2}$ Standby current           |  |              | 100 |            |     | $\mu\text{A}$ |      |
| $I_{DD3}$ Refresh average current   | Refresh mode: RAS cycling  |              | 27  |            | 27  | mA            | 4    |
| $I_{CC3}$ Refresh average current   | CAS = $V_{IH(C)}$  | -10          | 10  | -10        | 10  | $\mu\text{A}$ |      |
| $I_{BB3}$ Refresh average current   | $t_{RC} = t_{RC}(\text{min})$  |              | 200 |            |     | $\mu\text{A}$ |      |
| $I_{DD4}$ Page mode average current | Page mode: RAS = $V_{IH}$  |              | 27  |            | 27  | mA            | 4    |
| $I_{CC4}$ Page mode average current | CAS cycling  |              |     |            |     | A             | 5    |
| $I_{BB4}$ Page mode average current | $t_{PC} = t_{PC}(\text{min})$  |              | 200 |            |     | $\mu\text{A}$ |      |
| $I_{IL}$ Input leakage current      | $V_{BB} = -5\text{V}$<br>$0\text{V} \leq V_{IN} \leq -7\text{V}$ , all other pins not under test | -10          | 10  | -10        | 10  | $\mu\text{A}$ |      |
| $I_{OL}$ Output leakage current     | $D_{OUT}$ is disabled<br>$0\text{V} \leq V_{OUT} \leq +5.5\text{V}$                              | -10          | 10  | -10        | 10  | $\mu\text{A}$ |      |
| $V_{OH}$ Output high voltage        | $I_{OUT} = -5\text{mA}$  | 2.4          |     | 2.4        |     | V             | 3    |
| $V_{OL}$ Output low voltage         | $I_{OUT} = 4.2\text{mA}$   |              | 0.4 |            | 0.4 | V             | 3    |



## AC ELECTRICAL CHARACTERISTICS AND RECOMMENDED OPERATING CONDITIONS

( $T_A = 0$  to  $70^\circ\text{C}$ )<sup>1</sup>, ( $V_{DD} = 12\text{ V} \pm 10\%$ ;  $V_{CC} = 5\text{ V} \pm 10\%$ ;  $V_{SS} = 0\text{ V}$ ;  $V_{BB} = -5.7$  to  $-4.5\text{ V}$ )

| PARAMETER   | MMN 4116-2 |       | MMN 4116-3 |       | MMN 4116-4 |       | UNIT | NOTES |
|---|------------|-------|------------|-------|------------|-------|------|-------|
|   | min        | max   | min        | max   | min        | max   |      |       |
| $t_{RC}$ Random read or write cycle time                                    | 320        |       | 375        |       | 410        |       | ns   | 9     |
| $t_{RWC}$ Read-write cycle time   | 320        |       | 375        |       | 425        |       | ns   | 9     |
| $t_{RMW}$ Read modify write cycle time                                      | 320        |       | 405        |       | 500        |       | ns   | 9     |
| $t_{PC}$ Page mode cycle time   | 170        |       | 225        |       | 275        |       | ns   | 9     |
| $t_{RAC}$ Access time from $\overline{\text{RAS}}$                          |            | 150   |            | 200   |            | 250   | ns   | 10,12 |
| $t_{CAC}$ Access time from $\overline{\text{CAS}}$                          |            | 100   |            | 135   |            | 165   | ns   | 11,12 |
| $t_{OFF}$ Output buffer turn-off delay                                      | 0          | 40    | 0          | 50    | 0          | 60    | ns   | 13    |
| $t_T$ Transition time (rise and fall)                                       | 3          | 35    | 3          | 50    | 3          | 50    | ns   | 8     |
| $t_{RP}$ $\overline{\text{RAS}}$ precharge time                             | 100        |       | 120        |       | 150        |       | ns   |       |
| $t_{RAS}$ $\overline{\text{RAS}}$ pulse width                               | 150        | 10000 | 200        | 10000 | 250        | 10000 | ns   |       |
| $t_{RSH}$ $\overline{\text{RAS}}$ hold time                                 | 100        |       | 135        |       | 165        |       | ns   |       |
| $t_{CSH}$ $\overline{\text{CAS}}$ hold time                                 | 150        |       | 200        |       | 250        |       | ns   |       |
| $t_{RCD}$ $\overline{\text{RAS}}$ to $\overline{\text{CAS}}$ delay time     | 20         | 50    | 25         | 65    | 35         | 86    | ns   | 14    |
| $t_{CRP}$ $\overline{\text{CAS}}$ to $\overline{\text{RAS}}$ precharge time | -20        |       | -20        |       | -20        |       | ns   |       |
| $t_{ASR}$ Row address set-up time   | 0          |       | 0          |       | 0          |       | ns   |       |
| $t_{RAH}$ Row address hold time   | 20         |       | 25         |       | 35         |       | ns   |       |
| $t_{ASC}$ Column address set-up time  | -10        |       | -10        |       | -10        |       | ns   |       |
| $t_{CAH}$ Column address hold time  | 45         |       | 55         |       | 75         |       | ns   |       |
| $t_{AR}$ Column address hold time referenced to $\overline{\text{RAS}}$     | 95         |       | 120        |       | 160        |       | ns   |       |
| $t_{RCS}$ Read command set-up time  | 0          |       | 0          |       | 0          |       | ns   |       |
| $t_{RCH}$ Read command hold time  | 0          |       | 0          |       | 0          |       | ns   |       |
| $t_{WCH}$ Write command hold time   | 45         |       | 55         |       | 75         |       | ns   |       |
| $t_{WCR}$ Write command hold time referenced to $\overline{\text{RAS}}$     | 95         |       | 120        |       | 160        |       | ns   |       |
| $t_{WP}$ Write command pulse width  | 45         |       | 55         |       | 75         |       | ns   |       |
| $t_{RWL}$ Write command to $\overline{\text{RAS}}$ lead time                | 50         |       | 70         |       | 85         |       | ns   |       |
| $t_{CWL}$ Write command to $\overline{\text{CAS}}$ lead time                | 50         |       | 70         |       | 85         |       | ns   |       |
| $t_{DS}$ Data-in set-up time  | 0          |       | 0          |       | 0          |       | ns   | 15    |
| $t_{DH}$ Data-in hold time  | 45         |       | 55         |       | 75         |       | ns   | 15    |
| $t_{DHR}$ Data-in hold time referenced to $\overline{\text{RAS}}$           | 95         |       | 120        |       | 160        |       | ns   |       |
| $t_{CP}$ $\overline{\text{CAS}}$ precharge time (for page mode cycle only)  | 60         |       | 80         |       | 100        |       | ns   |       |
| $t_{REF}$ Refresh period  |            | 2     |            | 2     |            | 2     | ms   |       |
| $t_{WCS}$ $\overline{\text{WRITE}}$ command set-up time                     | -20        |       | -20        |       | -20        |       | ns   | 16    |
| $t_{CWD}$ $\overline{\text{CAS}}$ to $\overline{\text{WRITE}}$ delay        | 60         |       | 80         |       | 90         |       | ns   | 16    |
| $t_{RWD}$ $\overline{\text{RAS}}$ to $\overline{\text{WRITE}}$ delay        | 110        |       | 145        |       | 175        |       | ns   | 16    |

### NOTES

- $T_A$  is specified here for operation at frequencies to  $t_{RC} \geq t_{RC}(\text{min})$ . Operation at higher cycle rates with reduced ambient temperatures and higher power dissipation is permissible, however, provided AC operating parameters are met.
- All voltages referenced to  $V_{SS}$ .
- Output voltage will swing from  $V_{SS}$  to  $V_{CC}$  when activated with no current loading. For purposes of maintaining data in standby mode,  $V_{CC}$  may be reduced to  $V_{SS}$  without affecting refresh operations or data retention. However, the  $V_{OH}(\text{min})$  specification is not guaranteed in this mode.
- $I_{DD1}$ ,  $I_{DD3}$  and  $I_{DD4}$  depend on cycle rate.

5.  $I_{CC1}$  and  $I_{CC4}$  depend upon output loading. During read out of high level data  $V_{CC}$  is connected through a low impedance to data out. At all other times  $I_{CC}$  consists of leakage currents only.
6. Several cycles are required after power-up before proper device operation is achieved. Any 8 cycles which perform refresh are adequate for this purpose.
7. AC measurements assume  $t_T = 5 \text{ ns}$ .
8.  $V_{IHC}$  (min) or  $V_{IH}$  (min) and  $V_{IL}$  (max) are reference levels for measuring timing of input signals. Also, transition times are measured between  $V_{IHC}$  or  $V_{IH}$  and  $V_{IL}$ .
9. The specifications for  $t_{RC}$  (min) and  $t_{RWC}$  (min)  $t_{RMW}$  (min) are used only to indicate cycle time at which proper operation over the full temperature range ( $0^\circ\text{C} \leq T_{amb} \leq 70^\circ\text{C}$ ) is assured.
10. Assuming that  $t_{RCD} \leq t_{RCD}(\text{max})$ . If  $t_{RCD}$  is greater than the maximum recommended value shown in this table,  $t_{RAC}$  will increase by the amount that  $t_{RCD}$  exceeds the value shown.
11. Assuming that  $t_{RCD} \geq t_{RCD}(\text{max})$ .
12. Measured with a load equivalent to 2 TTL loads and 100 pF.
13.  $t_{OFF}$  (max) defines the time at which the output achieves the open circuit condition and is not referenced to output voltage levels.
14. Operation within the  $t_{RCD}$  (max) limit ensures that  $t_{RAC}$  (max) can be met.  $t_{RCD}$  (max) is specified as a reference point only; if  $t_{RCD}$  is greater than the specified  $t_{RCD}$  (max) limit, then access time is exclusively controlled by  $t_{CAC}$ .
15. These parameters are referenced to  $\overline{\text{CAS}}$  leading edge in early write cycles and to  $\overline{\text{WRITE}}$  leading edge in delayed write or read-modify-write cycles.
16.  $t_{WCS}$ ,  $t_{CWD}$  and  $t_{RWD}$  are not restrictive operating parameters. They are included in the data sheet as electrical characteristics only: If  $t_{WCS} \geq t_{WCS}(\text{min})$ , the cycle is an early write cycle and data output pin will remain open circuit (high impedance) throughout the entire cycle; If  $t_{CWD} \geq t_{CWD}(\text{min})$  and  $t_{RWD} \geq t_{RWD}(\text{min})$ , the cycle is a read-write cycle and the data out will contain data read from the selected cell; If neither of the above sets of conditions is satisfied the condition of the data out (at access time) is indeterminate.
17. Effective capacitance calculated from the equation  $C = \frac{\Delta t}{\Delta V}$  with  $\Delta v = 3$  volts and power supplies at nominal levels.
18.  $\overline{\text{CAS}} = V_{IHC}$  to disable  $D_{OUT}$ .

## DESCRIPTION

System oriented features include  $\pm 10\%$  tolerance on all power supplies, direct interfacing capability with high performance logic families such as Schottky TTL, maximum input noise immunity to minimize "false triggering" of the inputs (a common cause of soft errors), on-chip address and data registers which eliminate the need for interface registers, and two chip select methods to allow the user to determine the appropriate speed/power characteristics of his memory system. The MMN 4116 also incorporates several flexible timing/operating modes. In addition to the usual read, write, and read-modify-write cycles, the MMN 4116 is capable of delayed write cycles, page-mode operation and RAS-only refresh. Proper control of the clock inputs (RAS, CAS and WRITE) allows common I/O capability, two dimensional chip selection, and extended page boundaries (when operating in page mode).

## ADDRESSING

The 14 address bits required to decode 1 of the 16,384 cell locations within the MMN 4116 are multiplexed onto the 7 address inputs and latched into the on-chip address latches by externally applying two negative going TTL-level clocks. The first clock, the Row Address Strobe ( $\overline{\text{RAS}}$ ), latches the 7 row address bits into the chip. The second clock, the Column Address Strobe ( $\overline{\text{CAS}}$ ), subsequently latches the 7 column address bits into the chip. Each of these signals,  $\overline{\text{RAS}}$  and  $\overline{\text{CAS}}$ , triggers a sequence of events which are controlled by different delayed internal clocks. The two clock chains are linked together logically in such a way that the address multiplexing operation is done outside of the critical path timing sequence for read data access. The later events in the  $\overline{\text{CAS}}$  clock sequence are inhibited until the occurrence of a delayed signal derived from the  $\overline{\text{RAS}}$  clock chain. This "gated  $\overline{\text{CAS}}$ " feature allows the  $\overline{\text{CAS}}$  clock to be externally activated as soon as the Row Address Hold Time specification ( $t_{RAH}$ ) has been satisfied and the address inputs have been changed from Row address to Column address information. Note that CAS can be activated at any time after  $t_{RAH}$  and it will have no effect on the worst case data access time ( $t_{RAC}$ ) up to the point in time when the delayed row clock no longer inhibits the remaining sequence of column clocks. Two timing end-points result from the internal gating of  $\overline{\text{CAS}}$  which are called  $t_{RCD}(\text{min})$  and  $t_{RCD}(\text{max})$ . No data storage or reading errors will result if  $\overline{\text{CAS}}$  is applied to the MMN 4116 at a point in time beyond the  $t_{RCD}(\text{max})$  limit. However, access time will then be determined exclusively by the access time from  $\overline{\text{CAS}}$  ( $t_{CAC}$ ) rather than from  $\overline{\text{RAS}}$  ( $t_{RAC}$ ), and access time from  $\overline{\text{RAS}}$  will be lengthened by the amount that  $t_{RCD}$  exceeds the  $t_{RCD}(\text{max})$  limit.

## DATA INPUT/OUTPUT

Data to be written into a selected cell is latched into an on-chip register by a combination of  $\overline{\text{WRITE}}$  and  $\overline{\text{CAS}}$  while  $\overline{\text{RAS}}$  is active. The later of the signals ( $\overline{\text{WRITE}}$  or  $\overline{\text{CAS}}$ ) to make its negative transition is the strobe for the Data In ( $D_{\text{IN}}$ ) register. This permits several options in the write cycle timing. In a write cycle, if the  $\overline{\text{WRITE}}$  input is brought low (active) prior to  $\overline{\text{CAS}}$ , the  $D_{\text{IN}}$  is strobed by  $\overline{\text{CAS}}$ , and the set-up and hold times are referenced to  $\overline{\text{CAS}}$ . If the input data is not available at  $\overline{\text{CAS}}$  time or if it is desired that the cycle be a read-write cycle, the  $\overline{\text{WRITE}}$  signal will be delayed until after  $\overline{\text{CAS}}$  has made its negative transition. In this "delayed write cycle" the data input set-up and hold times are referenced to the negative edge of  $\overline{\text{WRITE}}$  rather than  $\overline{\text{CAS}}$ . (To illustrate this feature,  $D_{\text{IN}}$  is referenced to  $\overline{\text{WRITE}}$  in the timing diagrams depicting the read-write and page-mode write cycles while the "early write" cycle diagram shows  $D_{\text{IN}}$  referenced to  $\overline{\text{CAS}}$ ). Data is retrieved from the memory in a read cycle by maintaining  $\overline{\text{WRITE}}$  in the inactive or high state throughout the portion of the memory cycle in which  $\overline{\text{CAS}}$  is active (low). Data read from the selected cell will be available at the output within the specified access time.

## DATA OUTPUT CONTROL

The normal condition of the Data Output ( $D_{\text{OUT}}$ ) of the MMN 4116 is the high impedance (open-circuit) state. That is to say, anytime  $\overline{\text{CAS}}$  is at a high level, the  $D_{\text{OUT}}$  pin will be floating. The only time the output will turn on and contain either a logic 0 or logic 1 is at access time during a read cycle.  $D_{\text{OUT}}$  will remain valid from access time until  $\overline{\text{CAS}}$  is taken back to the inactive (high level) condition. If the memory cycle in progress is a read, read-modify write, or a delayed write cycle, then the data output will go from the high impedance state to the active condition, and at access time will contain the data read from the selected cell. This output data is the same polarity (not inverted) as the input data. Once having gone active, the output will remain valid until  $\overline{\text{CAS}}$  is taken to the precharge (logic 1) state, whether or not  $\overline{\text{RAS}}$  goes into precharge.

If the cycle in progress is an "early-write" cycle ( $\overline{\text{WRITE}}$  active before  $\overline{\text{CAS}}$  goes active), then the output pin will maintain the high impedance state throughout the entire cycle. Note that with this type of output configuration, the user is given full control of the  $D_{\text{OUT}}$  pin simply by controlling the placement of  $\overline{\text{WRITE}}$  command during a write cycle, and the pulse width of the Column Address Strobe during read operations. Note also that even though data is not latched at the output, data can remain valid from access time until the beginning of a subsequent cycle without paying any penalty in overall memory cycle time (stretching the cycle).

This type of output operation results in some very significant system implications.

**Common I/O Operation** — If all write operations are handled in the "early write" mode, then  $D_{\text{IN}}$  can be connected directly to  $D_{\text{OUT}}$  for a common I/O data bus.  $D_{\text{OUT}}$  will remain valid during a read cycle from  $t_{\text{CAC}}$  until  $\overline{\text{CAS}}$  goes back to a high level (precharge), allowing data to be valid from one cycle up until a new memory cycle begins with no penalty in cycle time. This also makes the  $\overline{\text{RAS}}/\overline{\text{CAS}}$  clock timing relationship very flexible.

**Two Methods of Chip Selection** — Since  $D_{\text{OUT}}$  is not latched,  $\overline{\text{CAS}}$  is not required to turn off the outputs of unselected memory devices in a matrix. This means that both  $\overline{\text{CAS}}$  and/or  $\overline{\text{RAS}}$  can be decoded for chip selection. If both  $\overline{\text{RAS}}$  and  $\overline{\text{CAS}}$  are decoded, then a two dimensional (X, Y) chip select array can be realized. **Extended Page Boundary** — Page — mode operation allows for successive memory cycles at multiple column locations of the same row address. By decoding  $\overline{\text{CAS}}$  as a page cycle select signal, the page boundary can be extended beyond the 128 column location in a single chip. (See page-mode operation).

## OUTPUT INTERFACE CHARACTERISTICS

The three state data output buffer presents the data output pin with a low impedance to  $V_{\text{CC}}$  for a logic 1 and a low impedance to  $V_{\text{SS}}$  for a logic 0. The effective resistance to  $V_{\text{CC}}$  (logic 1 state) is 420  $\Omega$  maximum and 135  $\Omega$  typically. The resistance to  $V_{\text{SS}}$  (logic 0 state) is 95  $\Omega$  maximum and 35  $\Omega$  typically.

The separate  $V_{\text{CC}}$  pin allows the output buffer to be powered from the supply voltage of the logic to which the chip is interfaced. During battery standby operation, the  $V_{\text{CC}}$  pin may have power removed without affecting the MMN 4116 refresh operation. This allows all system logic except the  $\overline{\text{RAS}}$  timing circuitry and the refresh address logic to be turned off during battery standby to conserve power.

## PAGE MODE OPERATION

The "Page Mode" feature of the MMN 4116 allows for successive memory operations at multiple column locations of the same row address with increased speed without an increase in power. This is done by strobing the row address into the chip and maintaining the  $\overline{\text{RAS}}$  signal at a logic 0 throughout all successive memory cycles in which the row address is common. This "page-mode" of operation will not dissipate the power associated with the negative going edge of  $\overline{\text{RAS}}$ . Also, the time required for strobing in a new row address is eliminated, thereby decreasing the access and cycle times. The page boundary of a single MMN 4116 is limited to the 128 column locations determined by all combi-

nations of the 7 column address bits. However, in system applications which utilize more than 16,384 data words, (more than one 16K memory block), the page boundary can be extended by using  $\overline{\text{CAS}}$  rather than  $\overline{\text{RAS}}$  as the chip select signal.  $\overline{\text{RAS}}$  is applied to all devices to latch the row address into each device and the  $\overline{\text{CAS}}$  is decoded and serves as a page cycle select signal. Only those devices which receive both  $\overline{\text{RAS}}$  and  $\overline{\text{CAS}}$  signals will execute a read or write cycle.

## REFRESH

Refresh of the dynamic cell matrix is accomplished by performing a memory cycle at each of the 128 row addresses within each 2 millisecond time interval. Although any normal memory cycle will perform the refresh operation, this function is most easily accomplished with "RAS-only" cycles. RAS-only refresh results in a substantial reduction in operating power. This reduction in power is reflected in the  $I_{DD3}$  specification.

## POWER CONSIDERATIONS

Most of the circuitry used in the MMN 4116 is dynamic and most of the power drawn is the result of an address strobe edge.

Consequently, the dynamic power is primarily a function of operating frequency rather than active duty cycle. This current characteristic of the MMN 4116 precludes inadvertent burn out of the device in the event that the clock inputs become shorted to ground due to system malfunction.

Although no particular power supply noise restriction exists other than the supply voltages remain within the specified tolerance limits, adequate decoupling should be provided to suppress high frequency noise resulting from the transient current of the device. This insures optimum system performance and reliability. Bulk capacitance requirements are minimal since the MMN 4116 draws very little steady state (DC) current.

In system applications requiring lower power dissipations, the operating frequency (cycle rate) of the MMN 4116 can be reduced and the (guaranteed maximum) average power dissipation of the device will be lowered in accordance with the  $I_{DD1}$  (max) spec limit equation.

Note: The MMN 4116 is guaranteed to have a maximum  $I_{DD1}$  requirement with an ambient temperature from 0° to 70°C.

1 microsecond cycle, results in a reduced maximum  $I_{DD1}$  requirement of under 20 mA with an ambient temperature range from 0° to 70°C.

Although  $\overline{\text{RAS}}$  and/or  $\overline{\text{CAS}}$  can be decoder and used as a chip select signal for the MMN 4116 overall system power is minimized if the Row Address Strobe ( $\overline{\text{RAS}}$ ) is used for this purpose. All unselected devices (those which do not receive a  $\overline{\text{RAS}}$ ) is used for this purpose. All unselected devices (those which do not receive a  $\overline{\text{RAS}}$ ) will remain in a low power (standby) mode regardless of the state of  $\overline{\text{CAS}}$ .

## POWER UP

The MMN 4116 requires no particular power supply sequencing so long as the Absolute Maximum Rating Conditions are observed. However, in order to insure compliance with the Absolute Maximum Ratings, MICROELECTRONICA recommends sequencing of power supplies such that  $V_{BB}$  is applied first and removed last.  $V_{BB}$  should never be more positive than  $V_{SS}$  when power is applied to  $V_{DD}$ .

Under system failure conditions in which one or more supplies exceed the specified limits significant additional margin against catastrophic device failure may be achieved by forcing  $\overline{\text{RAS}}$  and  $\overline{\text{CAS}}$  to the inactive state (high level).

After power is applied to the device, the MMN 4116 requires several cycles before proper device operation is achieved. Any 8 cycles which perform refresh are adequate for this purpose.

## CAPACITANCES

( $T_{amb} = 0$  to 70°C;  $V_{DD} = 12\text{ V} \pm 10\%$ ;  $V_{BB} = -5.7$  to  $-4.5\text{ V}$ ;  $V_{SS} = 0\text{V}$ )

| PARAMETER  | RATING |     |     | UNIT | NOTES |
|--|--------|-----|-----|------|-------|
|  | min    | typ | max |      |       |
| $C_{i1}$ Input capacitance ( $A_0$ — $A_6$ ) DIN |        | 4   | 5   | pF   | 17    |
| $C_{i2}$ Input capacitance RAS, CAS, WRITE       |        | 8   | 10  | pF   | 17    |
| $C_o$ Output capacitance ( $O_{OUT}$ )           |        | 5   | 7   | pF   | 17,18 |

**READ CYCLE**

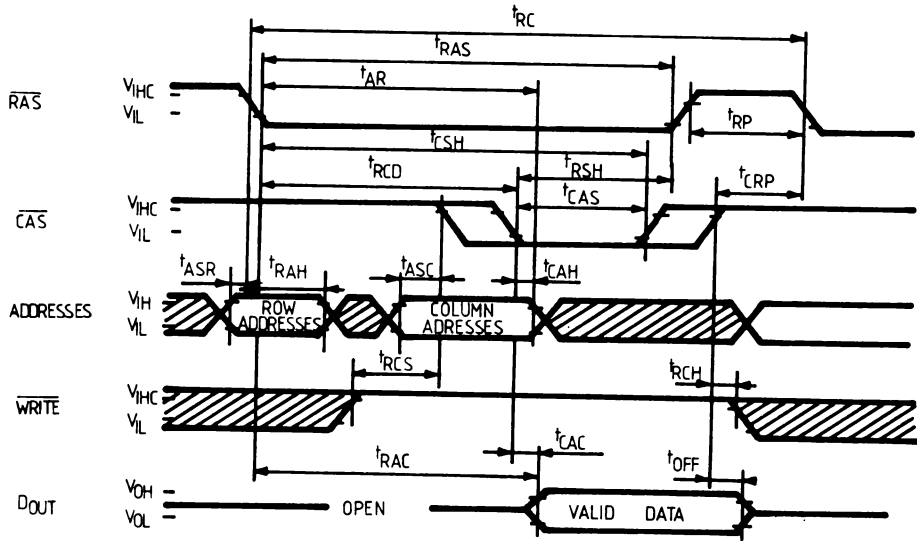

**WRITE CYCLE (EARLY WRITE)**

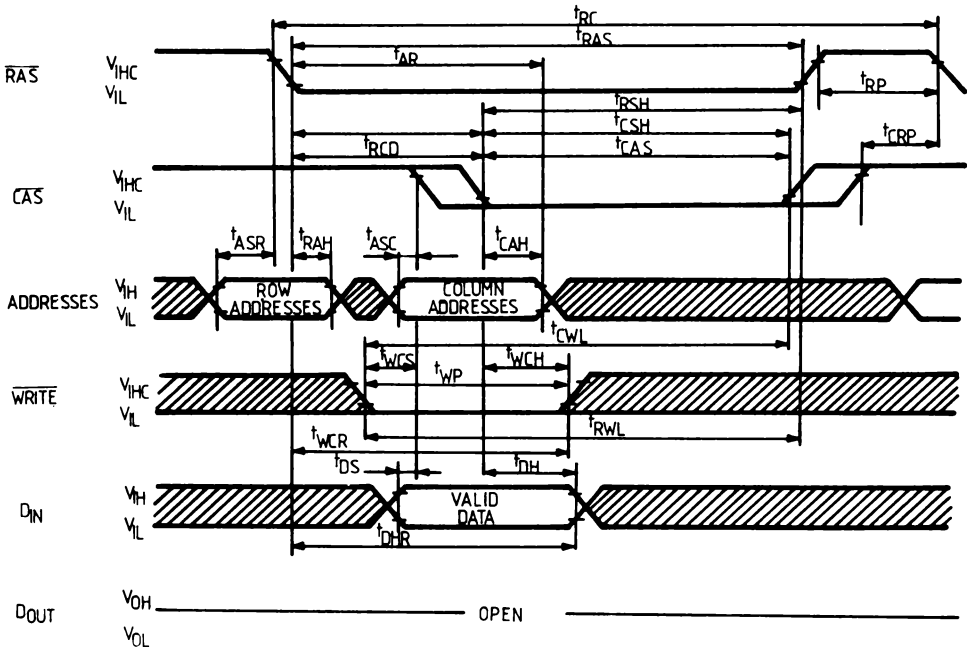

**READ WRITE / READ MODIFY - WRITE CYCLE**

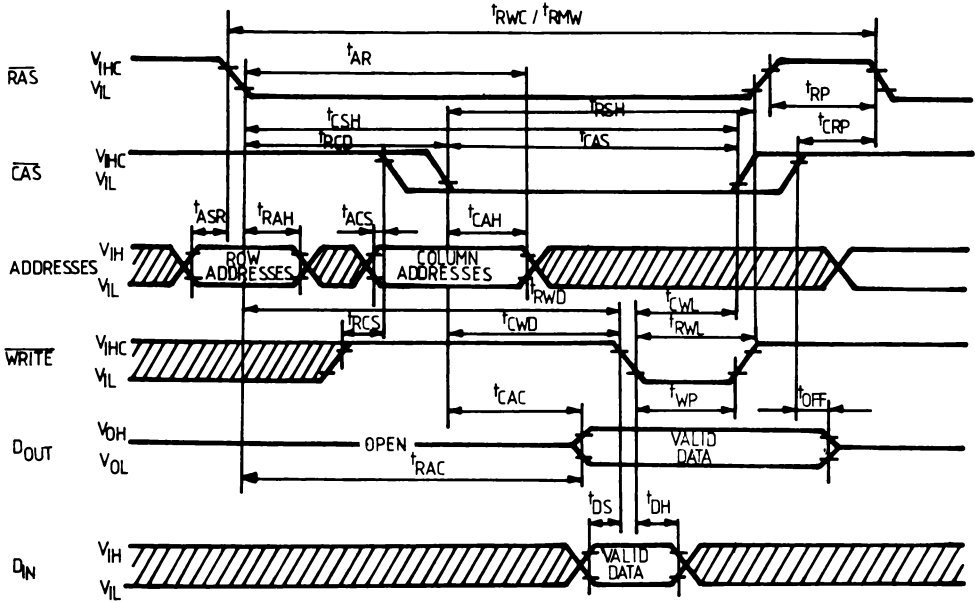

**"RAS-ONLY" REFRESH CYCLE**

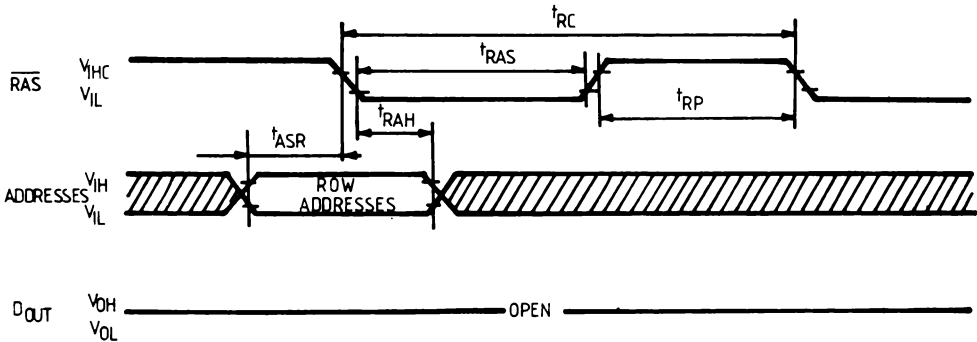

**PAGE MODE READ CYCLE**

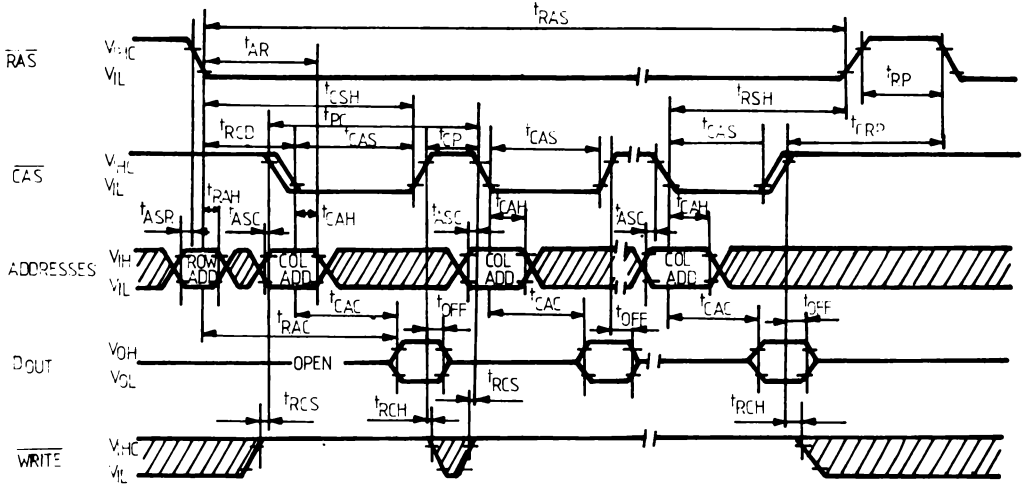

**PAGE MODE WRITE CYCLE**

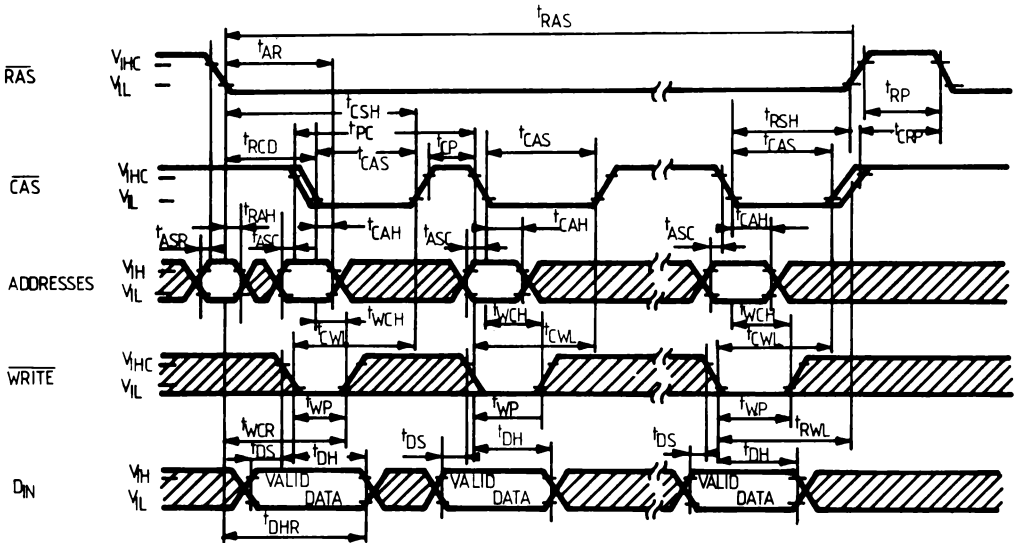

# DUAL 16 BIT STATIC SHIFT REGISTER

## GENERAL DESCRIPTION

MMP 02 is a dual 16 bit static shift register. It is a monolithic integrated circuit manufactured in standard Al-gate PMOS technology.

The circuit is designed to operate on a two phase clock,  $\phi 1$  and  $\phi 2$ .

For DC storage conditions,  $\phi 1$  must be a logic "0" and  $\phi 2$  must be a logic "1"

## FEATURES

- Two phase clock
- High speed operation DC to 1 MHz
- Low power consumption

## ABSOLUTE MAXIMUM RATINGS

|                 |                               |            |    |
|-----------------|-------------------------------|------------|----|
| $V_{DD}$        | Drain supply voltage          | -30...+0.3 | V  |
| $V_{GG}$        | Gate supply voltage           | -30...+0.3 | V  |
| $V_{\phi}, V_i$ | Clock and data input voltages | -30...+0.3 | V  |
| $P_{tot}$       | Total power dissipation       | 200        | mW |
| $T_A$           | Operating ambient temperature | 0...+70    | °C |
| $T_{stj}$       | Storage temperature           | -55...+150 | °C |

## CONNECTION DIAGRAM

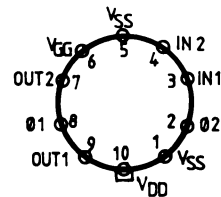
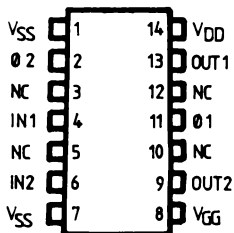



**STATIC ELECTRICAL CHARACTERISTICS**

( $T_A = 25^\circ\text{C}$  unless otherwise specified)

| PARAMETER   | TEST CONDITIONS                                 | VALUES |      |      | UNIT             |
|---|---|--------|------|------|------------------|
|   |   | min.   | typ. | max. |                  |
| $V_{IL}$ Data input level                         | "0" Logic                                       |        |      | -2   | V                |
| $V_{IH}$ Data input level                         | "1" Logic                                       | -10    |      |      | V                |
| $I_{LI}$ Data input leakage current               | $V_I = -20\text{ V}$                            |        |      | 1    | $\mu\text{A}$    |
| $I_{L\phi}$ Clock input leakage current           | $V_\phi = -26\text{ V}$                         |        |      | 100  | $\mu\text{A}$    |
| $R_{I\phi 2}$ Clock ( $\phi 2$ ) input resistance | $V_{\phi 1} = -26\text{ V}$<br>$V_{\phi 2} = 0$ | 60     |      |      | $\text{K}\Omega$ |
| $V_{\phi L}$ Clock level ( $\phi 1, \phi 2$ )     | "0" Logic                                       |        |      | -2   | v                |
| $V_{\phi H}$                                      | "1" Logic                                       | -26    |      | -28  | V                |
| $V_{OL}$ Output level                             | "0" Logic                                       |        | -0.5 | -1   | V                |
| $V_{OH}$  | "1" Logic                                       | -11    | -12  |      | V                |
| $R_{OL}$ Output resistance to ground              | "0" Logic at output                             |        | 2    | 3    | $\text{K}\Omega$ |
| $V_{OC}$ Output drive capability                  | $R_L = 4\text{ K}$ to ground                    | -5     |      |      | V                |
| $I_{DD}$ $V_{DD}$ power supply current drain      | $V_{DD} = -13\text{ V}$                         |        |      | 12   | $\text{mA}$      |
| $I_{GG}$ $V_{GG}$ power supply current drain      | $V_{GG} = -27\text{ V}$                         |        |      | 2    | $\text{mA}$      |

5

**DYNAMIC ELECTRICAL CHARACTERISTICS**

( $T_A = 25^\circ\text{C}$ ) unless otherwise specified

| PARAMETER  | TEST CONDITIONS | VALUES  |      |      | UNIT          |
|--|-----------------|---------|------|------|---------------|
|  |                 | min.    | typ. | max. |               |
| $f_\phi$ Clock frequency                         |                 | c.c. DC |      | 1    | MHz           |
| $t_{\phi 1}$ Clock pulse width                   |                 | 0.4     |      | 10   | $\mu\text{s}$ |
| $t_{\phi 2}$                                     |                 | 0.4     |      | 10   | $\mu\text{s}$ |
| $t_{\phi\phi}$ Clock delay $\phi 2$ vs. $\phi 1$ |                 | 0.01    |      | 10   | $\mu\text{s}$ |
| $t_r$ Clock pulse rise and fall times            | 10...90%        |         |      | 5    | $\mu\text{s}$ |
| $t_f$  |                 |         |      | 5    | $\mu\text{s}$ |
| $t_D$ Data pulse width                           |                 | 0.4     |      |      | $\mu\text{s}$ |

**TIMING DIAGRAM**

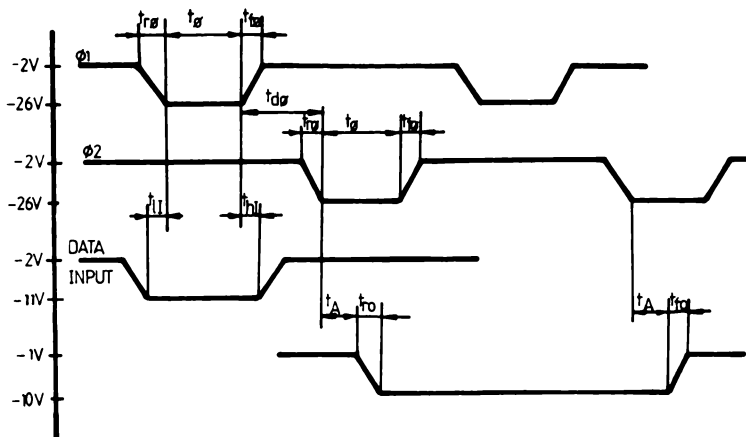

# 64 BIT DYNAMIC SHIFT REGISTER

## GENERAL DESCRIPTION

MMP 03 is a 64 bit dynamic shift register, manufactured in standard Al-gate PMOS technology. The on-chip clock generator and a separate output buffer supply yield an output level independent of clock frequency and amplitude.

## FEATURES

- Maximum operating frequency 1 MHz
- Operating with a single external phase
- TTL output compatible

## ABSOLUTE MAXIMUM RATINGS

|   |            |    |
|---|------------|----|
| Voltage on any pin with respect to $V_{SS}$ | -30...+0.3 | V  |
| $P_{tot}$ Total power dissipation           | 500        | mW |
| $T_A$ Operating ambient temperature         | 0...+70    | °C |
| $T_{stg}$ Storage temperature range         | -55...+150 | °C |

## PIN CONNECTIONS

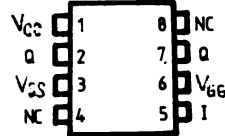
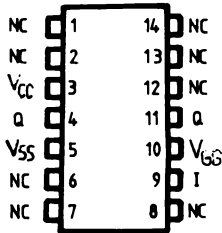

## TIMING DIAGRAM

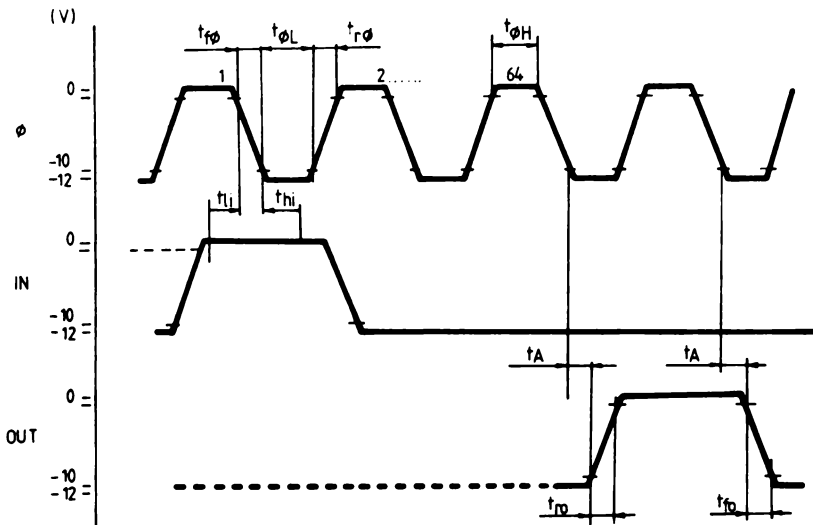

## STATIC ELECTRICAL CHARACTERISTICS

( $V_{GG} = -26...-28$  V,  $V_{DD} = -12...-14$  V,  $T_A = 0...+70^\circ\text{C}$ , standard load 50 pF in parallel with 20 kohm,  $V_{SS}$  grounded)

| PARAMETER                                       | TEST CONDITIONS   | VALUES |      |      | UNIT          |
|---|---|--------|------|------|---------------|
|   |   | min.   | typ. | max. |               |
| $V_{GG}$ Supply voltages                        |   | -28    | -27  | -26  | V             |
| $V_{CC}$  |   | -28    | -12  | +0.3 | V             |
| $V_{OL}$ Output level                           |   | -0.5   |      | 0    | V             |
| $V_{OH}$  |   | -14    | -12  | -10  | V             |
| $V_{\phi L}$ Clock signal level                 |   | -2     |      | +0.3 | V             |
| $V_{\phi H}$                                    |   | -28    | -12  | -9   | V             |
| $V_{IL}$ Data input level                       |   | -2     |      | +0.3 | V             |
| $V_{IH}$  |   | -28    | -12  | -9   | V             |
| $C_{\phi}$ Clock input capacitance              | $V_{\phi} = 0$  |        | 6    | 10   | pF            |
| $I_{LI}$ Data input leakage current             | $T_A = 25^\circ\text{C}$<br>$V_I = -15$ V<br>The other terminals at ground      |        |      | 1    | $\mu\text{A}$ |
| $I_{L\phi}$ Clock input leakage current         | $T_A = 25^\circ\text{C}$<br>$V_{\phi} = -28$ V<br>The other terminals at ground |        |      | 100  | $\mu\text{A}$ |
| $R_{OH}$ Output resistance (both output states) | $V_{DD} = -5$ V   |        | 250  | 500  | $\Omega$      |
| $R_{OL}$  |   |        | 250  | 500  | $\Omega$      |
| $I_{GG}$ Power supply current (see note 2)      | $V_{GG} = -27$ V<br>$f_{\phi} = 1$ MHz<br>$T_A = 25^\circ\text{C}$              |        | 5    | 6    | mA            |

## DYNAMIC ELECTRICAL CHARACTERISTICS

( $V_{GG} = -26...-28$  V,  $V_{CC} = -12...-14$  V,  $T_A = 0...+70^\circ\text{C}$ , standard load 50 pF in parallel with 20 kohm,  $V_{SS}$  grounded)

| PARAMETER                           | TEST CONDITIONS | VALUES |      |      | UNIT |
|-------------------------------------|-----------------|--------|------|------|------|
|                                     |                 | min.   | typ. | max. |      |
| $f_{\phi}$ Clock frequency          |                 | 0.01   |      | 1    | MHz  |
| $t_r$ Clock rise and fall times     | Note 1          |        |      | 100  | ns   |
| $t_f$                               |                 |        |      | 100  | ns   |
| $t_{DS}$ Data set-up time           |                 | 20     |      |      | ns   |
| $t_{DH}$ Data hold time             |                 | 75     |      |      | ns   |
| $t_{rO}$ Output rise and fall times |                 |        | 100  |      | ns   |
| $t_{fO}$                            |                 |        | 100  |      | ns   |
| $t_A$ Acces time                    |                 |        | 300  |      | ns   |

Note 1: These limits apply to the case of several registers driven by a single clock and have to be observed for proper time positioning of the various output signals.

Note 2: The output power supply current,  $I_{CC}$ , is load dependent. The typical total power dissipation is 300 mW.

# DUAL 3 - INPUT NOR GATE

## GENERAL DESCRIPTION

The MMP 102 is a monolithic integrated circuit, available in 10 — lead dual in line plastic package. The MMP 102 is manufactured in P-channel MOS technology.

## FEATURES

- High input resistance
- Inputs fully protected
- One supply voltage

## ABSOLUTE MAXIMUM RATINGS

(All voltages relative to  $V_{SS}$ )

|           |                               |            |    |
|-----------|-------------------------------|------------|----|
| $V_{DD}$  | Drain supply voltage          | -31...+0.3 | V  |
| $V_I$     | Input voltage                 | -25...+0.3 | V  |
| $T_A$     | Operating ambient temperature | 0...+70    | °C |
| $T_{stg}$ | Storage temperature           | -55...+125 | °C |

## PIN CONNECTIONS

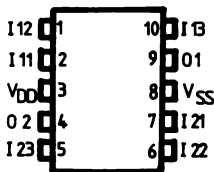

## TRUTH TABLE

| $I_1$ | $I_2$ | $I_3$ | O |
|-------|-------|-------|---|
| H     | H     | H     | L |
| H     | H     | L     | H |
| H     | L     | H     | H |
| H     | L     | L     | H |
| L     | H     | H     | H |
| L     | H     | L     | H |
| L     | L     | H     | H |
| L     | L     | L     | H |

**STATIC ELECTRICAL CHARACTERISTICS**

(T<sub>A</sub> = 25°C) unless otherwise specified

| PARAMETER   | TEST CONDITIONS  | VALUES |      |      | UNIT |
|---|--|--------|------|------|------|
|   |  | min.   | typ. | max. |      |
| I <sub>I</sub> Input current  | +V <sub>I</sub> = 25 V   | -10    |      |      | μA   |
| V <sub>OL</sub> Low level output voltage                            | V <sub>IH</sub> ≥ -2 V; V <sub>IL</sub> ≤ -9 V; R <sub>L</sub> = 1 M                             |        |      | -10  | V    |
| V <sub>OH</sub> High level output voltage                           | V <sub>IH</sub> ≥ -2 V; V <sub>IL</sub> ≤ -9 V; R <sub>L</sub> = 100 k                           | -1     |      |      | V    |
| V <sub>OL</sub> Low level output voltage at I <sub>O</sub> = +1 mA  | V <sub>IH</sub> ≥ -2 V; V <sub>IL</sub> ≤ -9 V   |        |      | -5   | V    |
| V <sub>OH</sub> High level output voltage at I <sub>O</sub> = -1 mA | V <sub>IH</sub> ≥ -2 V; V <sub>IL</sub> ≤ -9 V   | -4     |      |      | V    |
| I <sub>DD</sub> Medium supply current                               | R <sub>L</sub> = 1 M; C <sub>L</sub> = 60 pF; V <sub>I</sub> = -12 V<br>T/t = 2 : 1; f = 250 kHz |        | -1   |      | mA   |
| C <sub>I</sub> Input capacitance                                    | V <sub>DD</sub> = 0 V; V <sub>I</sub> = 0.2 V;<br>f = 0.5..2 MHz                                 |        |      | 6    | pF   |

**DYNAMIC ELECTRICAL CHARACTERISTICS**

(T<sub>A</sub> = 25°C) unless otherwise specified

| PARAMETER                               | TEST CONDITIONS | VALUES |      |      | UNIT |
|---|-----------------|--------|------|------|------|
|   |                 | min.   | typ. | max. |      |
| t <sub>PHL</sub> Propagation delay time |                 |        | 300  |      | ns   |
| t <sub>PHL</sub> Propagation delay time |                 |        | 200  |      | ns   |
| C <sub>St</sub> Stray capacitance       |                 |        |      | 30   | pF   |

**SCHEMATIC DIAGRAM**

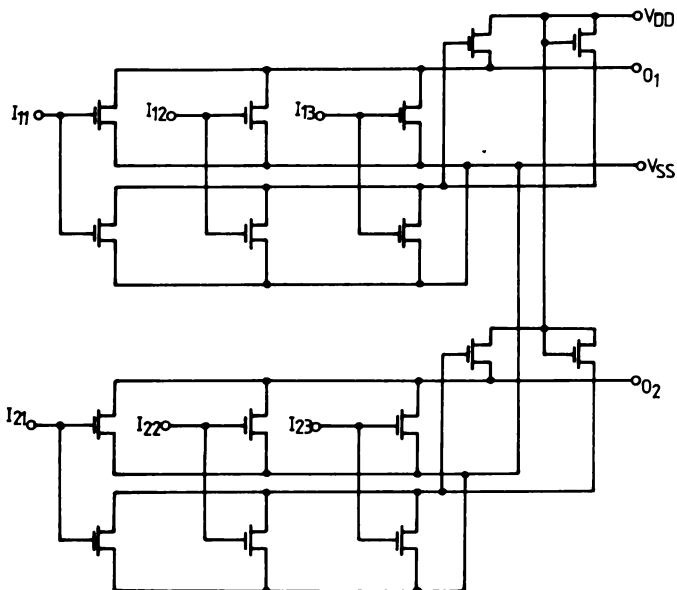

# QUAD 2 - INPUT NOR GATE

## GENERAL DESCRIPTION

The MMP 106 is a monolithic integrated circuit, available in 16 — lead dual in line plastic package. The MMP 106 is manufactured in P-channel MOS technology.

## FEATURES

- High input resistance
- Inputs fully protected
- Two supply voltage

## ABSOLUTE MAXIMUM RATINGS

|          |                               |            |    |
|----------|-------------------------------|------------|----|
| $V_{GG}$ | Gate supply voltage           | -30...+0.3 | V  |
| $V_{DD}$ | Drain supply voltage          | -30...+0.3 | V  |
| $V_I$    | Input voltage                 | -25...+0.3 | V  |
| $T_A$    | Operating ambient temperature | 0...+70    | °C |
| $T_S$    | Storage temperature           | -55...+150 | °C |

## RECOMMENDED OPERATING CONDITIONS

|          |                      |                                     |   |
|----------|----------------------|-------------------------------------|---|
| $V_{GG}$ | Gate supply voltage  | -27 <sup>-1</sup> <sub>+2</sub>     | V |
| $V_{DD}$ | Drain supply voltage | -13 <sup>-0.5</sup> <sub>+1.5</sub> | V |

## PIN CONNECTIONS

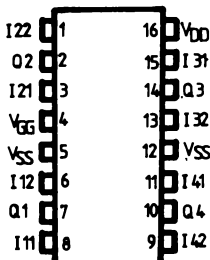

## TRUTH TABLE

| $I_{n1}$ | $I_{n2}$ | $O_n$ |
|----------|----------|-------|
| H        | H        | L     |
| H        | L        | H     |
| L        | H        | H     |
| L        | L        | H     |

$n = 1, 2, 3, 4$

**STATIC ELECTRICAL CHARACTERISTICS**

(T<sub>A</sub> = 25°C) unless otherwise specified

| PARAMETER  | TEST CONDITIONS   | VALUES |      |      | UNIT |
|--|---|--------|------|------|------|
|  |   | min.   | typ. | max. |      |
| I <sub>I</sub> Input current   | V <sub>I</sub> = -25 V  |        |      | 10   | μA   |
| V <sub>OL</sub> Low level output voltage                               | V <sub>IH</sub> ≥ -2 V; V <sub>IL</sub> ≤ -9 V;<br>R <sub>L</sub> = 1 M   | 10     |      |      | V    |
| V <sub>OH</sub> High level output voltage                              | V <sub>IH</sub> ≥ -2 V; V <sub>IL</sub> ≤ -9 V;<br>R <sub>L</sub> = 100 K |        |      | 1    | V    |
| V <sub>OL</sub> Low level output voltage at<br>I <sub>O</sub> = +1 mA  | V <sub>IH</sub> ≥ -2 V; V <sub>IL</sub> ≤ -9 V                            | 5      |      |      | V    |
| V <sub>OH</sub> High level output voltage<br>at I <sub>O</sub> = -1 mA | V <sub>IH</sub> ≥ -2 V; V <sub>IL</sub> ≤ -9 V                            |        |      | 4    | V    |

**DYNAMIC ELECTRICAL CHARACTERISTICS**

(T<sub>A</sub> = 25°C) unless otherwise specified

| PARAMETER                               | TEST CONDITIONS  | VALUES |      |      | UNIT |
|---|--|--------|------|------|------|
|   |  | min.   | typ. | max. |      |
| t <sub>PLH</sub> Propagation delay time |  |        | 320  |      | ns   |
| t <sub>PHL</sub> Propagation delay time |  |        | 120  |      | ns   |
| C <sub>IN</sub> Input capacitance       | V <sub>GG</sub> = V <sub>DD</sub> = 0 V<br>V <sub>I</sub> ≥ 0.2 V<br>f = 0.5...2 MHz |        |      | 1    | pF   |
| C <sub>st</sub> Stray capacitance       |  | 30     |      |      | pF   |

**SCHEMATIC DIAGRAM**

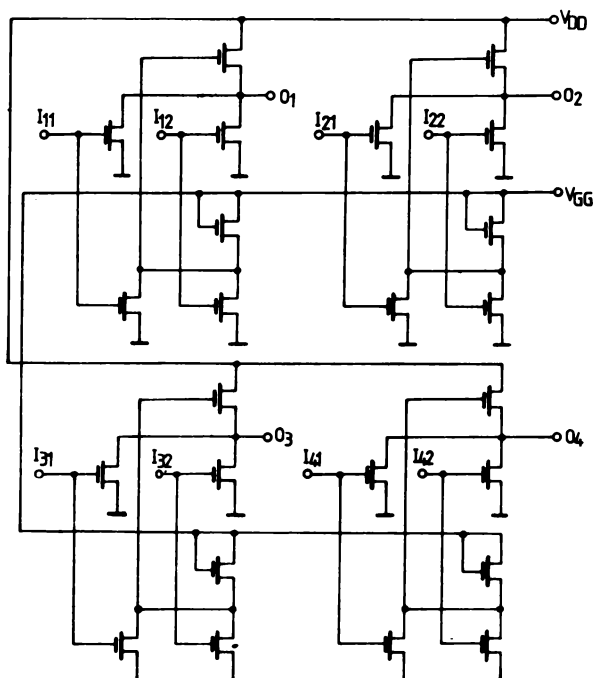

# QUAD 2 - INPUT AND (NAND) GATE

## GENERAL DESCRIPTION

The MMP 107 is a monolithic integrated circuit, available in 16 — lead dual in line plastic package. The MMP 107 is manufactured in P-channel MOS technology.

## FEATURES

- High input resistance
- Inputs fully protected
- Two supply voltages

## ABSOLUTE MAXIMUM RATINGS

|           |                               |             |    |
|-----------|-------------------------------|-------------|----|
| $V_{GG}$  | Gate supply voltage           | -31...+0.3  | V  |
| $V_{DD}$  | Drain supply voltage          | -31...+0.3  | V  |
| $V_I$     | Input voltage                 | -25...+0.3  | V  |
| $T_A$     | Operating ambient temperature | 0...+70     | °C |
| $T_{stq}$ | Storage temperature           | -55...+ 150 | °C |

## RECOMMENDED OPERATING CONDITIONS

|          |                      |      |      |   |
|----------|----------------------|------|------|---|
| $V_{GG}$ | Gate supply voltage  | -27  | -1   | V |
|          |                      | +2   |      |   |
| $V_{DD}$ | Drain supply voltage | -13  | -0.5 | V |
|          |                      | +1.5 |      |   |

## PIN CONNECTIONS

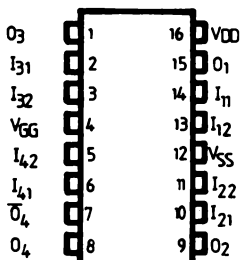

## TRUTH TABLE

| $I_{n1}$ | $I_{n2}$ | $O_n$ | $\bar{O}_4$ |
|----------|----------|-------|-------------|
| H        | H        | H     | L           |
| H        | L        | H     | L           |
| L        | H        | H     | L           |
| L        | L        | L     | H           |

$n = 1, 2, 3, 4$



**STATIC ELECTRICAL CHARACTERISTICS**

(T<sub>A</sub> = 25°C) unless otherwise specified

| PARAMETER  | TEST CONDITIONS  | VALUES |      |      | UNIT |
|--|--|--------|------|------|------|
|  |  | min.   | typ. | max. |      |
| I <sub>I</sub> Input current   | V <sub>I</sub> = -25 V   |        |      |      | μA   |
| V <sub>OL</sub> Low level output voltage                               | V <sub>IH</sub> ≥ -2 V; V <sub>IL</sub> ≤ -9 V;<br>R <sub>L</sub> = 1 MΩ   | 10     |      | 10   | V    |
| V <sub>OH</sub> High level output voltage                              | V <sub>IH</sub> ≥ -2 V; V <sub>IL</sub> ≤ -9 V;<br>R <sub>L</sub> = 100 KΩ |        |      | 1    | V    |
| V <sub>OL</sub> Low level output voltage<br>at I <sub>O</sub> = +1 mA  | V <sub>IH</sub> ≥ -2 V; V <sub>IL</sub> ≤ -9 V                             | 5      |      |      | V    |
| V <sub>OH</sub> High level output voltage<br>at I <sub>O</sub> = -1 mA | V <sub>IH</sub> ≥ -2 V; V <sub>IL</sub> ≤ -9 V                             |        |      | 4    | V    |

**DYNAMIC ELECTRICAL CHARACTERISTICS**

(T<sub>A</sub> = 25°C) unless otherwise specified

| PARAMETER  | TEST CONDITIONS  | VALUES |      |      | UNIT |
|--|--|--------|------|------|------|
|  |  | min.   | typ. | max. |      |
| t <sub>PLH</sub> Propagation delay time<br>for 01...03, 04 | V <sub>GG</sub> = V <sub>DD</sub> = 0 V<br>V <sub>I</sub> ≥ 0.2 V<br>f = 0.5...2 MHz |        | 320  |      | ns   |
| t <sub>PLH</sub> Propagation delay time for 04             |  |        | 150  |      | ns   |
| t <sub>PHL</sub> Propagation delay time                    |  |        | 200  |      | ns   |
| C <sub>IN</sub> Input capacitance                          |  |        |      | 6    | pF   |
| C <sub>st</sub> Stray capacitance for 01...03, 04          |  |        | 30   |      | pF   |
| C <sub>st</sub> Stray capacitance 04                       |  | 20     |      | pF   |      |

**SCHEMATIC DIAGRAM**

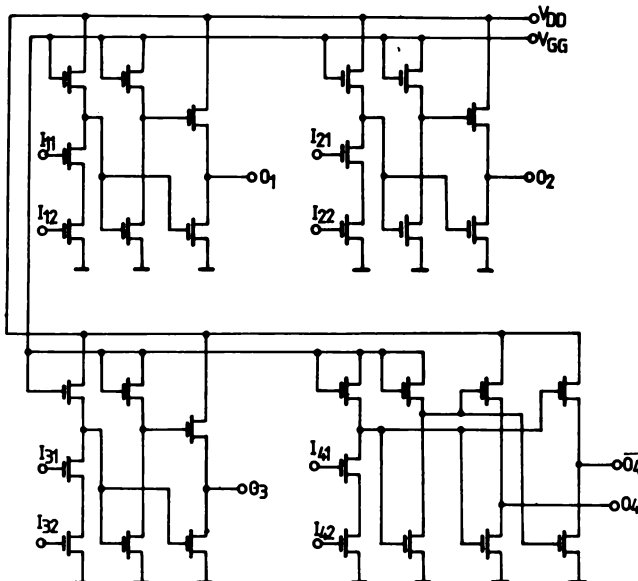

# 6-CHANNEL ANALOG SWITCH

## GENERAL DESCRIPTION

The MMP 115 contains six enhancement-mode P-channel MOS FETs designed to function as analog switches. In the ON state each switch will conduct current equally well in either direction, and in the OFF state each switch will block voltages up to 30 V peak-to-peak. The switches are integrated on a silicon substrate (body). The switches have a common drain terminal (D) which will function equally well as a common source. In the same manner, the source terminals (S) will function equally well as drains. Each gate (G) is provided with a normally OFF "pull-up" MOS FET which may be turned ON to provide a current source to the gate-driving circuit. The pull-ups are turned ON or OFF by connecting the "P" terminal to a negative supply or to the "B" terminal respectively.

## FEATURES

- Drain-source ON resistance 100 ohms
- Maximum switched voltage  $\pm 30\text{V}$
- Maximum voltage in each terminal to, substrate  $-30\text{V}$
- All inputs protected

## ABSOLUTE MAXIMUM RATINGS

|                            |            |                 |     |
|----------------------------|------------|-----------------|-----|
| Bulk to source voltage     | $V_{BS}$   | -2 to +30       | V   |
| Bulk to drain voltage      | $V_{BD}$   | +30             | V   |
| Drain to source voltage    | $V_{DS}$   | $\pm 30$        | V   |
| Bulk to gate voltage       | $V_{BG}$   | +35             | V   |
| Bulk to P terminal voltage | $V_{BP}$   | +35             | V   |
| Drain, source current      | $I_D, I_S$ | 100             | mA  |
| Power dissipation          | $P_d$      | 600             | mW* |
|                            |            | 900             | mW  |
| Storage temperature        | $T_{stg}$  | -55°C to 150 °C |     |
| Operating temperature      | $T_A$      | 0°C to 70 °C    |     |

\* for ceramic package

## PIN CONNECTIONS

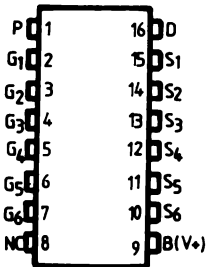

## SCHEMATIC DIAGRAM

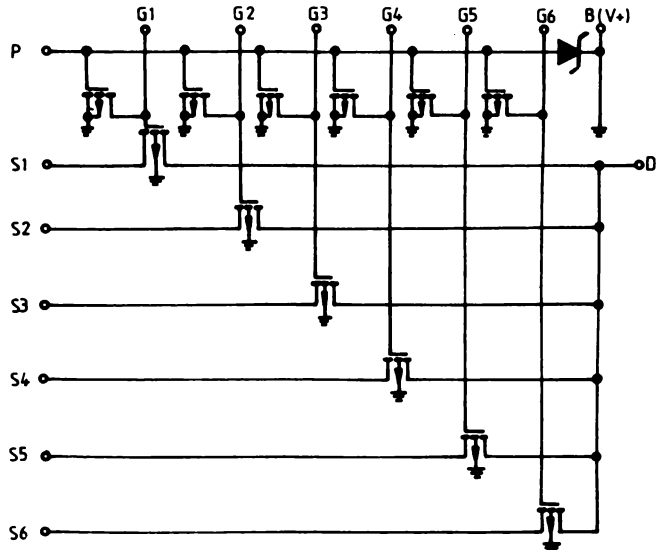

**STATIC ELECTRICAL CHARACTERISTICS**  $T_A = 25^\circ\text{C}$ 

| PARAMETER                                   | TEST CONDITIONS  | VALUES |      |      | UNIT     |
|---|--|--------|------|------|----------|
|   |  | min.   | typ. | max. |          |
| $V_T$ Threshold voltage                     | $I_D = -10 \mu\text{A}$ , $V_{SB} = V_{DG} = 0 \text{ V}$  | -1.5   |      | -4   | V        |
| $BV_{DS}$ Drain-source breakdown voltage    | $I_D = -50 \mu\text{A}$ , $V_{GS} = V_{SB} = 0 \text{ V}$  | -30    |      |      | V        |
| $BV_{SD}$ Source-drain breakdown voltage    | $I_S = -10 \mu\text{A}$ , $V_{GD} = 0 \text{ V}$   | -30    |      |      | V        |
| $BV_{GB}$ Gate-bulk breakdown voltage       | $I_G = -10 \mu\text{A}$ ,  | -30    |      |      | V        |
| $BV_{PB}$ P terminal-bulk breakdown voltage | $I_P = -10 \mu\text{A}$ , $V_{GB} = 0 \text{ V}$   | -30    |      |      | V        |
| $r_{ON}$ Drain-source on resistance         | $I_S = -1 \text{ mA}$ , $V_{DB} = 0 \text{ V}$<br>$V_{GD} = -30 \text{ V}$<br>$I_S = -1 \text{ mA}$ , $V_{DB} = -10 \text{ V}$ ,<br>$V_{GD} = -20 \text{ V}$<br>$I_S = -1 \text{ mA}$ , $V_{DB} = -20 \text{ V}$<br>$V_{GD} = -10 \text{ V}$ |        |      | 125  | $\Omega$ |
| $I_{S(OFF)}$ Source off leakage current     | $V_{SD} = -20 \text{ V}$ , $V_{GD} = 0 \text{ V}$  |        |      | 650  | $\Omega$ |
| $I_{D(OFF)}$ Drain off leakage current      | $V_{DS} = -20 \text{ V}$ , $V_{GS} = 0 \text{ V} = V_{SB}$   |        |      | -5   | nA       |
| $I_{G(ON)}$ Gate on current                 | $V_{GB} = -30 \text{ V}$ , $V_{PB} = -30 \text{ V}$  | -0.8   |      | -25  | nA       |
| $I_{GSS}$ Gate-channel leakage current      | $V_{GB} = -20 \text{ V}$   |        |      | -3.4 | mA       |
|   |  |        |      | -5   | nA       |

\*  $V_{DB} = 0 \text{ V}$ ,  $V_{PB} = 0 \text{ V}$ , unless otherwise specified

# 5-CHANNEL ANALOG SWITCH

## GENERAL DESCRIPTION

The MMP 116 contains five enhancement-mode P-channel MOS FETs designed to function as analog switches. In the ON state each switch will conduct current equally well in either direction, and in the OFF state each switch will block voltages up to 30 V peak-to-peak.

The switches are integrated on a silicon substrate. The switches have a common drain terminal (D) which will function equally well as a common source. In the same manner, the source terminal (S) will function equally well as drain. Each gate (G) is provided with a normally OFF pull-up MOS FET which may be turned on to provide a current source to the gate driving circuit. The pull-ups are turned ON or OFF by connecting the P terminal to a negative supply or to the B terminal respectively.

## FEATURES

- Drain-source ON resistance 100 ohms
- Maximum switched voltage  $\pm 30V$
- Maximum voltage in each terminal to, substrate  $-30 V$
- All inputs protected

## ABSOLUTE MAXIMUM RATINGS

|                            |            |                 |     |
|----------------------------|------------|-----------------|-----|
| Bulk to source voltage     | $V_{BS}$   | +30             | V   |
| Bulk to drain voltage      | $V_{BD}$   | +30             | V   |
| Drain to source voltage    | $V_{DS}$   | $\pm 30$        | V   |
| Bulk to gate voltage       | $V_{BG}$   | +35             | V   |
| Bulk to P terminal voltage | $V_{BP}$   | +35             | V   |
| Drain, source current      | $I_D, I_S$ | 100             | mA  |
| Power dissipation          | $P_d$      | 600             | mW* |
|                            |            | 900             | mW  |
| Storage temperature        | $T_{stg}$  | -55°C to 150 °C |     |
| Operating temperature      | $T_A$      | 0°C to 70 °C    |     |

\* for ceramic package

## PIN CONNECTIONS

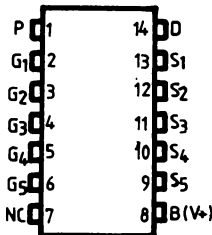

## SCHEMATIC DIAGRAM

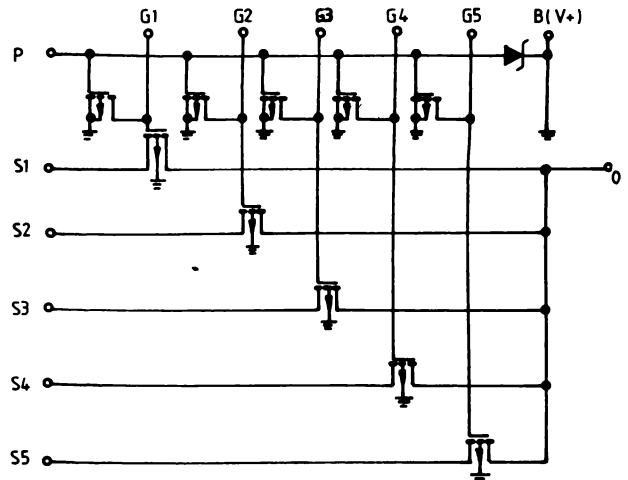

**STATIC ELECTRICAL CHARACTERISTICS**  $T_A = 25^\circ\text{C}$ 

| PARAMETER                                   | TEST CONDITIONS  | VALUES |      |      | UNIT     |
|---|--|--------|------|------|----------|
|   |  | min.   | typ. | max. |          |
| $V_T$ Threshold voltage                     | $I_D = -10 \mu\text{A}$ , $V_{SB} = V_{DG} = 0 \text{ V}$                      | -1.5   |      | -4   | V        |
| $BV_{DS}$ Drain-source breakdown voltage    | $I_D = -50 \mu\text{A}$ , $V_{GS} = V_{SB} = 0 \text{ V}$                      | -30    |      |      | V        |
| $BV_{SD}$ Source-drain breakdown voltage    | $I_S = -10 \mu\text{A}$ , $V_{GD} = 0 \text{ V}$                               | -30    |      |      | V        |
| $BV_{GB}$ Gate-bulk breakdown voltage       | $I_G = -10 \mu\text{A}$ ,  | -30    |      |      | V        |
| $BV_{PB}$ P terminal-bulk breakdown voltage | $I_P = -10 \mu\text{A}$ , $V_{GB} = 0 \text{ V}$                               | -30    |      |      | V        |
| $r_{ON}$ Drain-source on resistance         | $I_S = -1 \text{ mA}$ , $V_{DB} = 0 \text{ V}$<br>$V_{GD} = -30 \text{ V}$     |        |      | 125  | $\Omega$ |
|   | $I_S = -1 \text{ mA}$ , $V_{DB} = -10 \text{ V}$ ,<br>$V_{GD} = -20 \text{ V}$ |        |      | 200  | $\Omega$ |
|   | $I_S = -1 \text{ mA}$ , $V_{DB} = -20 \text{ V}$ ,<br>$V_{GD} = -10 \text{ V}$ |        |      | 650  | $\Omega$ |
| $I_{S(OFF)}$ Source off leakage current     | $V_{SD} = -20 \text{ V}$ , $V_{GD} = 0 \text{ V}$                              |        |      | -5   | nA       |
| $I_{D(OFF)}$ Drain off leakage current      | $V_{DS} = -20 \text{ V}$ , $V_{GS} = 0 \text{ V} = V_{SB}$                     |        |      | -25  | nA       |
| $I_{G(ON)}$ Gate on current                 | $V_{GB} = -30 \text{ V}$ , $V_{PB} = -30 \text{ V}$                            | -0.8   |      | -3.4 | mA       |
| $I_{GSS}$ Gate-channel leakage current      | $V_{GB} = -20 \text{ V}$   |        |      | -5   | nA       |

\*  $V_{DB} = 0 \text{ V}$ ,  $V_{PB} = 0 \text{ V}$ , unless otherwise specified

# 5-CHANNEL ANALOG SWITCHES

## GENERAL DESCRIPTION

The MMP 117 contains six enhancement-mode P-channel MOS FETs designed to function as analog switches. In the ON state each switch will conduct current equally well in either direction, and in the OFF state each switch will block voltages up to 20 V peak-to-peak.

The switches are integrated on a silicon substrate (body). The drains of five of the switches are internally connected to the source of the sixth switch. This arrangement is intended for use of the device as a 5-channel first-level and one-channel second-level multiplexer. Each of the six gates are provided with an internal "pull-up" current which may be turned ON or OFF by connecting the pull-up control terminal (P) to a negative supply or to the body (B) terminal.

## FEATURES

- Drain-source ON resistance 100 ohms
- Maximum switched voltage  $\pm 30\text{V}$
- Maximum voltage in each terminal to, substrate  $-30\text{V}$
- All inputs protected

## ABSOLUTE MAXIMUM RATINGS

|                            |            |           |                 |     |
|----------------------------|------------|-----------|-----------------|-----|
| Bulk to source voltage     | $V_{BS}$   | -2 to +30 | +30             | V   |
| Bulk to drain voltage      | $V_{BD}$   |           | +30             | V   |
| Drain to source voltage    | $V_{DS}$   |           | $\pm 30$        | V   |
| Bulk to gate voltage       | $V_{BG}$   |           | +35             | V   |
| Bulk to P terminal voltage | $V_{BP}$   |           | +35             | V   |
| Drain, source current      | $I_D, I_S$ |           | 100             | mA  |
| Power dissipation          | $P_d$      |           | 600             | mW* |
|                            |            |           | 900             | mW  |
| Storage temperature        | $T_{stg}$  |           | -55°C to 150 °C |     |
| Operating temperature      | $T_A$      |           | 0°C to 70 °C    |     |

\* for ceramic package

## PIN CONNECTIONS

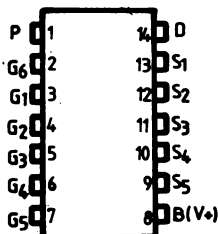

## SCHEMATIC DIAGRAM

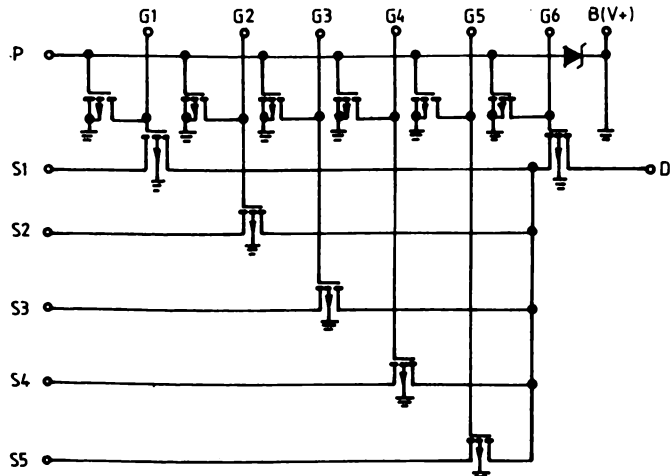

**STATIC ELECTRICAL CHARACTERISTICS** ( $T_{amb} = 25^{\circ}\text{C}$ )

| PARAMETER                                   | TEST CONDITIONS  | VALUES |      |      | UNIT     |
|---|--|--------|------|------|----------|
|   |  | min.   | typ. | max. |          |
| $V_T$ Threshold voltage                     | $I_D = -10 \mu\text{A}, V_{SB} = V_{DG} = 0 \text{ V}$                     | -1.5   |      | -4   | V        |
| $BV_{DS}$ Drain-source breakdown voltage    | $I_D = -50 \mu\text{A}, V_{GS} = V_{SB} = 0 \text{ V}$                     | -30    |      |      | V        |
| $BV_{SD}$ Source-drain breakdown voltage    | $I_S = -10 \mu\text{A}, V_{GD} = 0 \text{ V}$                              | -30    |      |      | V        |
| $BV_{GB}$ Gate-bulk breakdown voltage       | $I_G = -10 \mu\text{A},$   | -30    |      |      | V        |
| $BV_{PB}$ P terminal-bulk breakdown voltage | $I_P = -10 \mu\text{A}, V_{GB} = 0 \text{ V}$                              | -30    |      |      | V        |
| $r_{ON}$ Drain-source on resistance         | $I_S = -1 \text{ mA}, V_{DB} = 0 \text{ V}$<br>$V_{GD} = -30 \text{ V}$    |        |      | 125  | $\Omega$ |
|   | $I_S = -1 \text{ mA}, V_{DB} = -10 \text{ V},$<br>$V_{GD} = -20 \text{ V}$ |        |      | 200  | $\Omega$ |
|   | $I_S = -1 \text{ mA}, V_{DB} = -20 \text{ V}$<br>$V_{GD} = -10 \text{ V}$  |        |      | 650  | $\Omega$ |
|   | $V_{SD} = -20 \text{ V}, V_{GD} = 0 \text{ V}$                             |        |      | -5   | nA       |
| $I_{S(OFF)}$ Source off leakage current     | $V_{DS} = -20 \text{ V}, V_{GS} = 0 \text{ V} = V_{SB}$                    |        |      | -25  | nA       |
| $I_{D(OFF)}$ Drain off leakage current      | $V_{GB} = -30 \text{ V}, V_{PB} = -30 \text{ V}$                           | -0.8   |      | -3.4 | mA       |
| $I_{G(ON)}$ Gate on current                 | $V_{GB} = -20 \text{ V}$   |        |      | -5   | nA       |
| $I_{GSS}$ Gate-channel leakage current      |  |        |      |      |          |

\*  $V_{DB} = 0 \text{ V}, V_{PB} = 0 \text{ V},$  unless otherwise specified

# 3x2-CHANNEL ANALOG SWITCHES

## GENERAL DESCRIPTION

The MMP 119 contains six enhancement-mode P-channel MOS FETs designed to function as analog switches. In the ON state each switch will conduct current equally well in either direction, and in the OFF state each switch will block voltage up to 30 V peak-to-peak. The switches are integrated onto a silicon substrate (body) and are internally connected into two groups of three switches per group. This arrangement facilitates the switching or multiplexing of differential analog signals. Each group has a common drain terminal ( $D_1$  and  $D_2$ ) which will function equally well as a common source. Each gate terminal (G) controls a pair of switches and is provided with a normally-OFF „pull-up” MOS FET which may be turned ON to provide a current source to the gate-driving circuit. The pull-ups are turned ON or OFF by connecting the „P” terminal to a negative supply or to the „B” terminal respectively.

## FEATURES

- Drain-source ON resistance 100 ohms
- Maximum switched voltage  $\pm 30V$
- Maximum voltage in each terminal to, substrate  $-30 V$
- All inputs protected

## APPLICATIONS

- Switching analog signals such as differential inputs
- Multiplexing

## ABSOLUTE MAXIMUM RATINGS

|                            |            |                               |    |
|----------------------------|------------|-------------------------------|----|
| Bulk to source voltage     | $V_{BS}$   | +30                           | V  |
| Bulk to drain voltage      | $V_{BD}$   | +30                           | V  |
| Drain to source voltage    | $V_{DS}$   | $\pm 30$                      | V  |
| Bulk to gate voltage       | $V_{BG}$   | +35                           | V  |
| Bulk to P terminal voltage | $V_{BP}$   | +35                           | V  |
| Drain, source current      | $I_D, I_S$ | 100                           | mA |
| Power dissipation          | $P_d$      | 600 mW <sub>a</sub><br>900 mW |    |
| Storage temperature        | $T_{stg}$  | -55°C to 150 °C               |    |
| Operating temperature      | $T_A$      | 0°C to 70 °C                  |    |

\* for ceramic package

## PIN CONNECTIONS

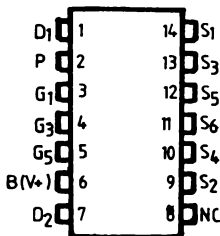

## SCHEMATIC DIAGRAM

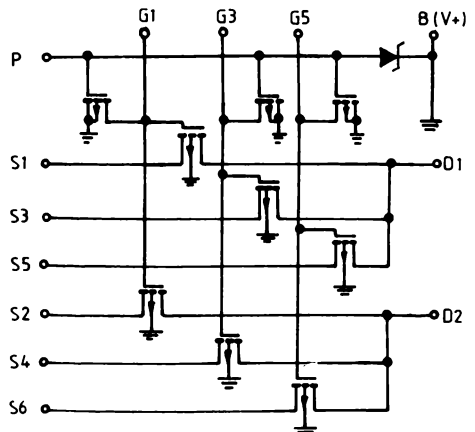



**STATIC ELECTRICAL CHARACTERISTICS**  $T_A = -25^\circ\text{C}$ 

| PARAMETER                                   | TEST CONDITIONS  | VALUES |      |      | UNIT     |
|---|--|--------|------|------|----------|
|   |  | min.   | typ. | max. |          |
| $V_T$ Threshold voltage                     | $I_D = -10 \mu\text{A}$ , $V_{SB} = V_{DG} = 0 \text{ V}$                      | -1.5   |      | -4   | V        |
| $BV_{DS}$ Drain-source breakdown voltage    | $I_D = -50 \mu\text{A}$ , $V_{GS} = V_{SB} = 0 \text{ V}$                      | -30    |      |      | V        |
| $BV_{SD}$ Source-drain breakdown voltage    | $I_S = -10 \mu\text{A}$ , $V_{GD} = 0 \text{ V}$                               | -30    |      |      | V        |
| $BV_{GB}$ Gate-bulk breakdown voltage       | $I_G = -10 \mu\text{A}$  | -30    |      |      | V        |
| $BV_{PB}$ P terminal-bulk breakdown voltage | $I_P = -10 \mu\text{A}$ , $V_{GB} = 0 \text{ V}$                               | -30    |      |      | V        |
| $r_{ON}$ Drain-source on resistance         | $I_S = -1 \text{ mA}$ , $V_{DB} = 0 \text{ V}$<br>$V_{GD} = -30 \text{ V}$     |        |      | 125  | $\Omega$ |
|   | $I_S = -1 \text{ mA}$ , $V_{DB} = -10 \text{ V}$ ,<br>$V_{GD} = -20 \text{ V}$ |        |      | 200  | $\Omega$ |
|   | $I_S = -1 \text{ mA}$ , $V_{DB} = -20 \text{ V}$ ,<br>$V_{GD} = -10 \text{ V}$ |        |      | 650  | $\Omega$ |
| $I_{S(OFF)}$ Source off leakage current     | $V_{SD} = -20 \text{ V}$ , $V_{GD} = 0 \text{ V}$                              |        |      | -5   | nA       |
| $I_{D(OFF)}$ Drain off leakage current      | $V_{DS} = -20 \text{ V}$ , $V_{GS} = 0 \text{ V} = V_{SB}$                     |        |      | -25  | nA       |
| $I_{G(ON)}$ Gate on current                 | $V_{GB} = -30 \text{ V}$ , $V_{PB} = -30 \text{ V}$                            | -0.8   |      | -3.4 | mA       |
| $I_{GSS}$ Gate-channel leakage current      | $V_{GB} = -20 \text{ V}$   |        |      | -5   | nA       |

\*  $V_{DB} = 0 \text{ V}$ ,  $V_{PB} = 0 \text{ V}$ , unless otherwise specified

# 2x2-CHANNEL ANALOG SWITCH

## GENERAL DESCRIPTION

The MMP 122 contains four enhancement-mode P-channel MOS FETs designed to function as analog switches. In the ON state each switch will conduct current equally well in either direction, and in the OFF state each switch will block voltages up to 30 V peak-to-peak. The switches are integrated onto a silicon substrate (body) and are internally connected into two groups of two switches per group. This arrangement facilitates the switching or multiplexing of differential analog signals. Each group has a common drain terminal ( $D_1$  and  $D_2$ ) which will function equally well as a common source. Each gate terminal (G) controls a pair of switches and is provided with a normally-OFF "pull-up" MOS FET which may be turned ON to provide a current source to a gate-driving circuit. The pull-ups are turned ON or OFF by connecting the "P" terminal to a negative supply or to the "B" terminal respectively.

## FEATURES

- Drain-source ON resistance 100 ohms
- Maximum switched voltage  $\pm 30V$
- Maximum voltage in each terminal to, substrate  $-30 V$
- All inputs protected

## APPLICATIONS

- Switching analog signals such as differential inputs
- Multiplexing

## ABSOLUTE MAXIMUM RATINGS

|                            |            |                                |
|----------------------------|------------|--------------------------------|
| Bulk to source voltage     | $V_{BS}$   | +30 V                          |
| Bulk to drain voltage      | $V_{BD}$   | +30 V                          |
| Drain to source voltage    | $V_{DS}$   | $\pm 30 V$                     |
| Bulk to gate voltage       | $V_{BG}$   | +35 V                          |
| Bulk to P terminal voltage | $V_{BP}$   | +35 V                          |
| Drain, source current      | $I_D, I_S$ | 100 mA                         |
| Power dissipation          | $P_d$      | 600 mW,<br>900 mW              |
| Storage temperature        | $T_{stg}$  | $-55^\circ C$ to $150^\circ C$ |
| Operating temperature      | $T_A$      | $0^\circ C$ to $70^\circ C$    |

\* for ceramic package

## CONNECTION DIAGRAM

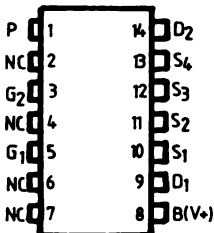

## SCHEMATIC DIAGRAM

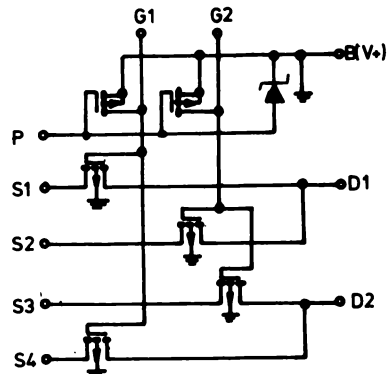

**STATIC ELECTRICAL CHARACTERISTICS**  $T_A = 25^\circ\text{C}$ 

| PARAMETER                                   | TEST CONDITIONS  | VALUES |      |      | UNIT     |
|---|--|--------|------|------|----------|
|   |  | min.   | typ. | max. |          |
| $V_T$ Threshold voltage                     | $I_D = -10 \mu\text{A}$ , $V_{SB} = V_{DG} = 0 \text{ V}$                      | -1.5   |      | -4   | V        |
| $BV_{DS}$ Drain-source breakdown voltage    | $I_D = -50 \mu\text{A}$ , $V_{GS} = V_{SB} = 0 \text{ V}$                      | -30    |      |      | V        |
| $BV_{SD}$ Source-drain breakdown voltage    | $I_S = -10 \mu\text{A}$ , $V_{GD} = 0 \text{ V}$                               | -30    |      |      | V        |
| $BV_{GB}$ Gate-bulk breakdown voltage       | $I_G = -10 \mu\text{A}$ ,  | -30    |      |      | V        |
| $BV_{PB}$ P terminal-bulk breakdown voltage | $I_P = -10 \mu\text{A}$ , $V_{GB} = 0 \text{ V}$                               | -30    |      |      | V        |
| $r_{ON}$ Drain-source on resistance         | $I_S = -1 \text{ mA}$ , $V_{DB} = 0 \text{ V}$<br>$V_{GD} = -30 \text{ V}$     |        |      | 125  | $\Omega$ |
|   | $I_S = -1 \text{ mA}$ , $V_{DB} = -10 \text{ V}$ ,<br>$V_{GD} = -20 \text{ V}$ |        |      | 200  | $\Omega$ |
|   | $I_S = -1 \text{ mA}$ , $V_{DB} = -20 \text{ V}$<br>$V_{GD} = -10 \text{ V}$   |        |      | 650  | $\Omega$ |
| $I_{S(OFF)}$ Source off leakage current     | $V_{SD} = -20 \text{ V}$ , $V_{GD} = 0 \text{ V}$                              |        |      | -5   | nA       |
| $I_{D(OFF)}$ Drain off leakage current      | $V_{DS} = -20 \text{ V}$ , $V_{GS} = 0 \text{ V} = V_{SB}$                     |        |      | -25  | nA       |
| $I_{G(ON)}$ Gate on current                 | $V_{GB} = -30 \text{ V}$ , $V_{PB} = -30 \text{ V}$                            | -0.8   |      | -3.4 | mA       |
| $I_{GSS}$ Gate-channel leakage current      | $V_{GB} = -20 \text{ V}$   |        |      | -5   | nA       |

\*  $V_{DB} = 0 \text{ V}$ ,  $V_{PB} = 0 \text{ V}$ , unless otherwise specified

# 4-CHANNEL ANALOG SWITCH

## GENERAL DESCRIPTION

The MMP 124 contains four enhancement-mode P-channel MOS FETs designed to function as analog switches. In the ON state each switch will conduct current equally well in either direction, and in the OFF state each switch will block voltages up to 30 V peak-to-peak. The switches are integrated on a silicon substrate (body). The switches have a common drain terminal (D) which will function equally well as a common source. In the same manner, the source terminals (S) will function equally well as drains. Each gate (G) is provided with a normally-OFF „pull-up” MOS FET which may be turned ON to provide a current source to a gate-driving circuit. The pull-ups are turned ON or OFF by connecting the „P” terminal to a negative supply or to the „B” terminal respectively.

## FEATURES

- Drain-source ON resistance 100 Ωs
- Maximum switched voltage ± 30 V
- Maximum voltage in each terminal to substrate -30 V
- All inputs protected

## APPLICATIONS

- Switching analog signals
- Multiplexing

## ABSOLUTE MAXIMUM RATINGS

|                            |            |                |
|----------------------------|------------|----------------|
| Bulk to source voltage     | $V_{BS}$   | + 30 V         |
| Bulk to drain voltage      | $V_{BD}$   | + 30 V         |
| Drain to source voltage    | $V_{DS}$   | ± 30 V         |
| Bulk to gate voltage       | $V_{BG}$   | + 35 V         |
| Bulk to P terminal voltage | $V_{BP}$   | + 35 V         |
| Drain, source current      | $I_D, I_S$ | 100 mA         |
| Power dissipation          | $P_d$      | 600 mW         |
|                            |            | 900 mW*        |
| Storage temperature        | $T_{stg}$  | -55°C to 150°C |
| Operating temperature      | $T_c$      | 0°C to 70°C    |

\* for ceramic package

## PIN CONNECTIONS

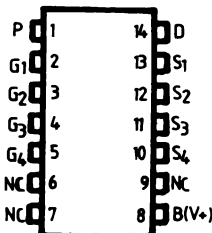

## SCHEMATIC DIAGRAM

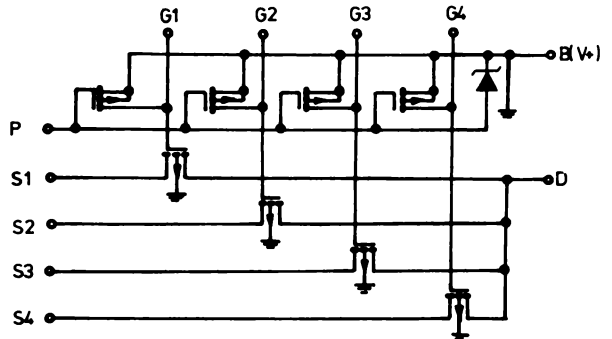

**STATIC ELECTRICAL CHARACTERISTICS**  $T_A = 25^\circ\text{C}$ 

| PARAMETER                                   | TEST CONDITIONS  | VALUES |      |      | UNIT     |
|---|--|--------|------|------|----------|
|   |  | min.   | typ. | max. |          |
| $V_T$ Threshold voltage                     | $I_D = -10 \mu\text{A}$ , $V_{SB} = V_{DG} = 0 \text{ V}$                      | -1.5   |      | -4   | V        |
| $BV_{DS}$ Drain-source breakdown voltage    | $I_D = -50 \mu\text{A}$ , $V_{GS} = V_{SB} = 0 \text{ V}$                      | -30    |      |      | V        |
| $BV_{SD}$ Source-drain breakdown voltage    | $I_S = -10 \mu\text{A}$ , $V_{GD} = 0 \text{ V}$                               | -30    |      |      | V        |
| $BV_{GB}$ Gate-bulk breakdown voltage       | $I_G = -10 \mu\text{A}$ ,  | -30    |      |      | V        |
| $BV_{PB}$ P terminal-bulk breakdown voltage | $I_P = -10 \mu\text{A}$ , $V_{GB} = 0 \text{ V}$                               | -30    |      |      | V        |
| $r_{ON}$ Drain-source on resistance         | $I_S = -1 \text{ mA}$ , $V_{DB} = 0 \text{ V}$<br>$V_{GD} = -30 \text{ V}$     |        |      | 125  | $\Omega$ |
|   | $I_S = -1 \text{ mA}$ , $V_{DB} = -10 \text{ V}$ ,<br>$V_{GD} = -20 \text{ V}$ |        |      | 200  | $\Omega$ |
|   | $I_S = -1 \text{ mA}$ , $V_{DB} = -20 \text{ V}$<br>$V_{GD} = -10 \text{ V}$   |        |      | 650  | $\Omega$ |
| $I_{S(OFF)}$ Source off leakage current     | $V_{SD} = -20 \text{ V}$ , $V_{GD} = 0 \text{ V}$                              |        |      | -5   | nA       |
| $I_{D(OFF)}$ Drain off leakage current      | $V_{DS} = -20 \text{ V}$ , $V_{GS} = 0 \text{ V} = V_{SB}$                     |        |      | -25  | nA       |
| $I_{G(ON)}$ Gate on current                 | $V_{GB} = -30 \text{ V}$ , $V_{PB} = -30 \text{ V}$                            | -0.8   |      | -3.4 | mA       |
| $I_{GSS}$ Gate-channel leakage current      | $V_{GB} = -20 \text{ V}$   |        |      | -5   | nA       |

\*  $V_{DB} = 0 \text{ V}$ ,  $V_{PB} = 0 \text{ V}$ , unless otherwise specified

# 1 000: 1 STATIC FREQUENCY DIVIDER

## GENERAL DESCRIPTION

The MMP 131 types are 1000:1 static frequency dividers integrated circuits fabricated in standard PMOS aluminium-gate technology. The circuit contains 11 Master-Slave Flip-Flops and a presetting logic. The first 10 Flip-Flops are dividing the frequency and the 11th is for the generation of the output pulse.

The circuit is available either with the preset internally connected or with external preset. The MMP 131 types are supplied in 4-lead (TO-72) or 8-lead (TO-99) metal case and 8-lead dual-in-line plastic package (MP-48)

## FEATURES

- One supply voltage only (max  $V_{DD} = -20$  V)
- Low power consumption
- Maximum input signal frequency 25 kHz

## APPLICATIONS

- Frequency divider
- Relays
- Switches with time delay

## ABSOLUTE MAXIMUM RATINGS

|           |                                    |                |
|-----------|------------------------------------|----------------|
| $V_{DD}$  | Supply voltage                     | -24 to +0,3 V  |
| $V_I$     | Voltage between any pin and ground | -24 to +0,3 V  |
| $I_O$     | Output current                     | -2 mA          |
| $T_A$     | Operating temperature              | 0 to 70 °C     |
| $T_{stg}$ | Storage temperature                | -33 to +125 °C |

## PIN CONNECTIONS

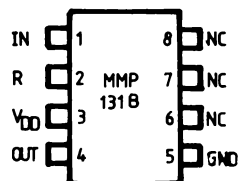
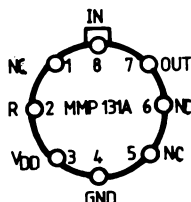
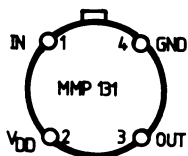

## BLOCK DIAGRAM

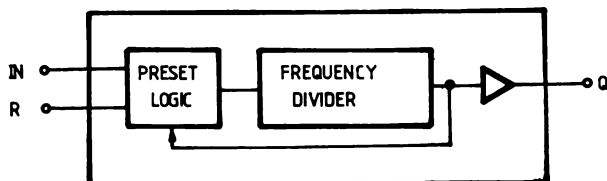

**STATIC ELECTRICAL CHARACTERISTICS** $(T_A = 25^\circ\text{C}$ , unless otherwise specified)

| PARAMETER                     | CONDITIONS<br>$V_{DD} = -19\text{ V}$ | VALUES |      | UNIT          |
|-------------------------------|---------------------------------------|--------|------|---------------|
|                               |                                       | min    | max. |               |
| $V_{DD}$ Supply voltage       |                                       | -20    | -18  | V             |
| $I_{DD}$ Supply current       |                                       | -4     |      | V             |
| $V_{IH}$ Input high voltage   |                                       | -2     |      | V             |
| $V_{IL}$ Input low voltage    |                                       |        | -12  | V             |
| $R_I$ Input resistance        |                                       | 10     |      | $M\Omega$     |
| $V_{OH}$ Output high voltage  | $I_O = -1\text{ mA}$                  | -7     |      | V             |
| $V_{OL}$ Output low voltage   |                                       |        | -15  | V             |
| $I_{OH}$ Output drive current | $R_L = 10\text{ k}\Omega$             |        | -1   | mA            |
| $I_{OL}$ Output sink current  | $R_L = 10\text{ k}\Omega$             | -10    |      | $\mu\text{A}$ |

**DYNAMIC ELECTRICAL CHARACTERISTICS** $(T_A = 25^\circ\text{C}$ , unless otherwise specified)

| PARAMETER                                     | CONDITIONS<br>$V_{DD} = -19\text{ V}$ | VALUES |      | UNIT          |
|---|---------------------------------------|--------|------|---------------|
|   |                                       | min.   | max. |               |
| <b>Input signal</b>                           |                                       |        |      |               |
| $f_i$ Input signal frequency                  |                                       | 0      | 25   | kHz           |
| $t_{WL}$ Low voltage pulse width              |                                       | 10     |      | $\mu\text{s}$ |
| $t_{WH}$ High voltage pulse width             |                                       | 15     |      | $\mu\text{s}$ |
| $t_{THL}, t_{TLH}$ Input rise and fall times  |                                       |        | 2    | $\mu\text{s}$ |
| <b>Output signal</b>                          |                                       |        |      |               |
| $t_{WH}$ High voltage pulse width             |                                       | 5      |      | $\mu\text{s}$ |
| $t_{PLH}$ Propagation delay time              |                                       |        | 15   | $\mu\text{s}$ |
| $t_{TLH}$ Output rise times                   |                                       |        | 5    | $\mu\text{s}$ |
| $t_{THL}$ Output fall time                    |                                       |        | 10   | $\mu\text{s}$ |
| <b>Preset signal</b>                          |                                       |        |      |               |
| $t_{WL}$ Low voltage pulse width              |                                       | 10     |      | $\mu\text{s}$ |
| $t_{THL}, t_{TLH}$ Preset rise and fall times |                                       |        | 2    | $\mu\text{s}$ |

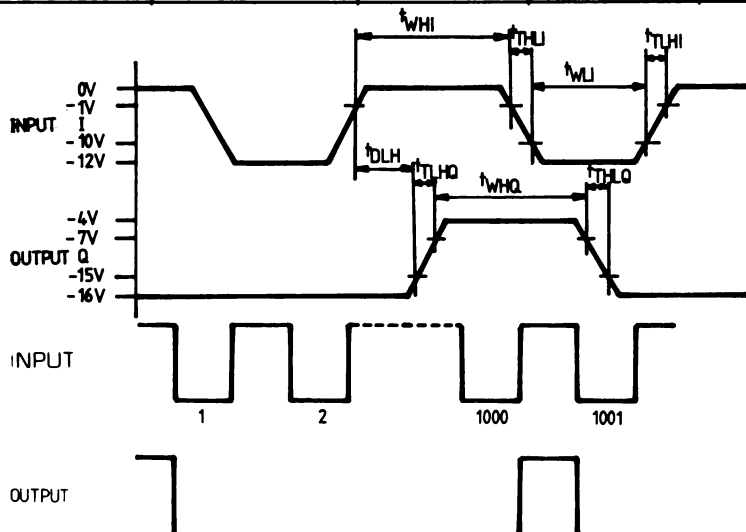
**TIMING DIAGRAM**

# 256-BIT DYNAMIC SHIFT REGISTER

## GENERAL DESCRIPTION

The MMP 156 contains one 256-bit shift register with one serial input and one serial output. It dissipates very little power and uses a one-phase external clock. The device has a low impedance push-pull output buffer which, when appropriately biased is capable of interfacing direct with MOS, DTL, TTL and other loads.

The buffer supply terminal  $P_2$  is a separate supply which determines the output LOW signal only. This provides an output level that is independent of both the amplitude and width of the clock pulse. The MMP 156 is a MOS standard aluminium gate technology, available in 14 lead dual-in-line package.

## FEATURES

- Single clock signal
- 1 MHz operation guaranteed
- Low power consumption

## ABSOLUTE MAXIMUM RATINGS

|           |  |               |
|-----------|--|---------------|
|           | Voltages on all data inputs, clock inputs and supply terminals with reference to $P_0$ | -30 to +0.3 V |
| $P_{tot}$ | Power dissipation  | 500 mW        |
| $T_A$     | Operating temperature  | 0 to 70 °C    |
| $T_{stg}$ | Storage temperature  | -33 to 125 °C |

## PIN CONNECTIONS

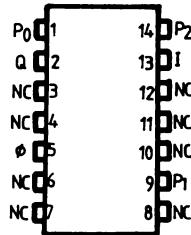

## BLOCK DIAGRAM

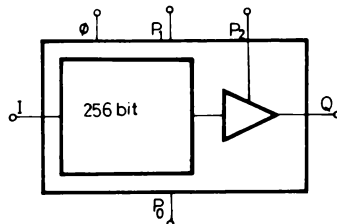



**STATIC ELECTRICAL CHARACTERISTICS**

( $V_{P1} = -26$  to  $-28$  V,  $V_{P2} = -12$  to  $-14$  V,  $T_A = 25^\circ\text{C}$ ,  $P_O =$  grounded, standard load of  $20\text{ k}\Omega$  in parallel with  $50\text{ pF}$  to  $P_O$ )

| PARAMETER                             | TEST CONDITIONS | VALUES |      |      | UNIT     |
|---------------------------------------|-----------------|--------|------|------|----------|
|                                       |                 | min.   | typ. | max. |          |
| $V_{P1}$ Supply voltages              |                 | -28    | -26  | -24  | V        |
| $V_{P2}$                              |                 | -14    | -13  | -12  | V        |
| $V_{\phi H}$ Clock pulse high voltage |                 | -2     |      | +0,3 | V        |
| $V_{\phi L}$ Clock pulse low voltage  |                 | -28    | -12  | -9   | V        |
| $V_{IH}$ Input high voltage           |                 | -2     |      | +0,3 | V        |
| $V_{IL}$ Input low voltage            |                 | -28    | -12  | -9   | V        |
| $V_{QH}$ Output high voltage          |                 | -0,5   |      | 0    | V        |
| $V_{QL}$ Output low voltage           |                 | -14    |      | -10  | V        |
| $R_{QH}$ Output high resistance       |                 |        |      | 500  | $\Omega$ |
| $R_{QL}$ Output low resistance        |                 |        |      | 500  | $\Omega$ |
| $-I_{P1}$ Power supply current        |                 |        |      | 10   | mA       |

NOTES: 1. The output buffer power supply current  $I_{P2}$  is almost entirely dependent on the external load.  
 2. The active level voltage is the low voltage level.

**DYNAMIC ELECTRICAL CHARACTERISTICS**

$T_A = 25^\circ\text{C}$

| PARAMETER                          | TEST CONDITIONS | VALUES |      |      | UNIT          |
|------------------------------------|-----------------|--------|------|------|---------------|
|                                    |                 | min.   | typ. | max. |               |
| $f_\phi$ Clock rate                | MMP 156         | 0,01   |      | 1    | MHz           |
|                                    | MMP 156-1       | 0,01   |      | 0,8  | MHz           |
| $t_{\phi L}$ Clock pulse width     | MMP 156         | 0,5    |      | 50   | $\mu\text{s}$ |
|                                    | MMP 156-1       | 0,6    |      | 50   | $\mu\text{s}$ |
| $t_{r\phi}$ Clock pulse rise time  |                 |        |      | 100  | ns            |
| $t_{f\phi}$ Clock pulse fall time  |                 |        |      | 100  | ns            |
| $t_{HI}$ Data lead time            |                 | 100    |      |      | ns            |
| $t_{Hl}$ Data hold time            |                 | 100    |      |      | ns            |
| $T_{rO}$ Output rise and fall time |                 |        |      | 150  | ns            |
| $t_A$ Delay time                   |                 |        |      | 400  | ns            |

**TIMING DIAGRAM**

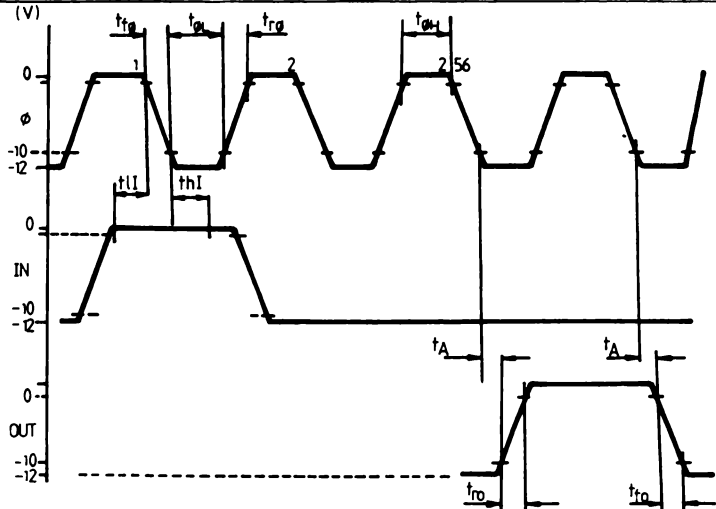

# DIGITAL MULTIMETER LOGIC

## GENERAL DESCRIPTION

MMP 190 is a digital multimeter logic integrated circuit fabricated in PMOS enhancement-depletion aluminium gate technology. The circuit consists of 2 internal oscillators (one for multiplexing, one for counting), a 4 decades BCD counter, an output multiplexer which can drive a LED or LCD 3 3/4 digit display and an autoranging and dual-slope A/D conversion control logic. MMP 190 is supplied in 28-lead dual-in-line plastic packages.

## FEATURES

- 3 3/4 digit digital multimeter logic (max. 599.9)
- autoranging
- multiplexed BCD output
- dual-slope integration
- overrange indicated (blinking)
- low-power dissipation
- CMOS compatibility

## APPLICATIONS

- digital multimeter
- decade counter

## ABSOLUTE MAXIMUM RATINGS

|           |  |             |    |
|-----------|--|-------------|----|
| $V_{DD}$  | Supply voltage                                 | -20 to +0.3 | V  |
| $V_I$     | Voltage between any pin and ground             | -20 to +0.3 | V  |
| $I_F$     | Input current ( $V_I = 0.3$ V; $V_{SS} = 0$ V) | 0 to 1      | mA |
| $T_A$     | Operating ambient temperature                  | -55 to +70  | °C |
| $T_{stg}$ | Storage temperature                            | -55 to +125 | °C |

## PIN CONNECTIONS

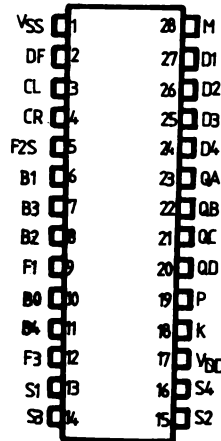

| PIN | SYMBOL   | PIN FUNCTION              | PIN | SYMBOL   | PIN FUNCTION              |
|-----|----------|---------------------------|-----|----------|---------------------------|
| 1   | $V_{SS}$ | Supply voltage            | 15  | $S_2$    | Dual-slope control output |
| 2   | DF       | LCD frequency output      | 16  | $S_4$    | "                         |
| 3   | CL       | External clock input      | 17  | $V_{DD}$ | Supply voltage            |
| 4   | CR       | Counting clock input      | 18  | K        | Analog input              |
| 5   | $F_{2S}$ | Range select input        | 19  | P        | Polarity output           |
| 6   | $B_1$    | Measuring range output    | 20  | $Q_D$    | BCD output                |
| 7   | $B_3$    | "                         | 21  | $Q_C$    | "                         |
| 8   | $B_2$    | "                         | 22  | $Q_B$    | "                         |
| 9   | $F_1$    | Range select input        | 23  | $Q_A$    | "                         |
| 10  | $B_0$    | Measuring range output    | 24  | $D_4$    | Digit selection output    |
| 11  | $B_4$    | "                         | 25  | $D_3$    | "                         |
| 12  | $F_3$    | Range select input        | 26  | $D_2$    | "                         |
| 13  | $S_1$    | Dual-slope control output | 27  | $D_1$    | "                         |
| 14  | $S_3$    | "                         | 28  | M        | Scan oscillator input     |

## STATIC ELECTRICAL CHARACTERISTICS

( $T_A = 25^\circ\text{C}$ , unless otherwise specified)

| PARAMETER   | TEST CONDITIONS                                | VALUES       |            | UNIT |
|---|--|--------------|------------|------|
|   |  | MIN.         | MAX.       |      |
| $V_{DD}$ Supply voltage   | reference                                      | 0            | 0          | V    |
| $V_{SS}$ Supply voltage   | $V_{DD} = 0\text{ V}$                          | 8            | 14         | V    |
| $V_{IL}$ K input low voltage  | $V_{DD} = 0\text{ V}$<br>$f_N = 30\text{ kHz}$ | 0            | $V_{SS}-7$ | V    |
| $V_{IH}$ K input high voltage   | $V_{DD} = 0\text{ V}$<br>$f_N = 30\text{ kHz}$ | $V_{SS}-2$   | $V_{SS}$   | V    |
| $V_{IL}$ Input low voltage<br>(except K input)  | $V_{DD} = 0\text{ V}$<br>$f_N = 30\text{ kHz}$ | 0            | $V_{SS}-7$ | V    |
| $V_{IH}$ Input high voltage<br>(except K input)   | $V_{DD} = 0\text{ V}$<br>$f_N = 30\text{ kHz}$ | $V_{SS}-0.5$ | $V_{SS}$   | V    |
| $V_{OL}$ Output low voltage<br>( $Q_A, Q_B, Q_C, Q_D, D_1,$<br>$D_2, D_3, D_4, P$ outputs)    | $I_O = 25\ \mu\text{A}$                        | 0            | 1          | V    |
| $V_{OH}$ Output high voltage<br>( $Q_A, Q_B, Q_C, Q_D, D_1,$<br>$D_2, D_3, D_4, P$ outputs)   | $I_O = -200\ \mu\text{A}$                      | $V_{SS}-1$   | $V_{SS}$   | V    |
| $V_{OL}$ Output low voltage<br>( $B_0, B_1, B_2, B_3, B_4, S_1,$<br>$S_2, S_3, S_4$ outputs)  | $I_O = 50\ \mu\text{A}$                        | 0            | 1          | V    |
| $V_{OH}$ Output high voltage<br>( $B_0, B_1, B_2, B_3, B_4, S_1,$<br>$S_2, S_3, S_4$ outputs) | $I_O = -200\ \mu\text{A}$                      | $V_{SS}-1$   | $V_{SS}$   | V    |
| $V_{OL}$ DF output low voltage  | $I_O = 50\ \mu\text{A}$                        | 0            | 1          | V    |
| $V_{OH}$ DF output high voltage   | $I_O = -50\ \mu\text{A}$                       | $V_{SS}-1$   | $V_{SS}$   | V    |
| $P_d$ Power dissipation   | $V_{DD}-V_{SS} = 12\text{ V}$<br>open outputs  |              | 70         | mW   |

## DYNAMIC ELECTRICAL CHARACTERISTICS

( $T_A = 25^\circ\text{C}$ , unless otherwise specified)

| PARAMETER   | TEST CONDITIONS  | VALUES    |      | UNIT                |
|---|--|-----------|------|---------------------|
|   |  | MIN.      | MAX. |                     |
| $t_d$ Delay time between<br>K input and S outputs | $C_L = 200\text{ pF}$<br>$R_L = 10\text{ Mohm}$                |           | 4    | $\mu\text{s}$       |
| $f_N$ Counter oscillator frequency                | $V_{DD}-V_{SS} = -12\text{ V}$                                 | 0         | 100  | kHz                 |
| $F_{NV}$ Counting frequency stability             | $V_{SS} = 12 \pm 1\text{ V}$                                   | $\pm 3$   |      | $\%/V$              |
| $F_{NT}$ Counting frequency stability             | $V_{SS} = 12\text{ V}$<br>$T_O = 0\text{ to }70^\circ\text{C}$ | $\pm 0.8$ |      | $\%/^\circ\text{C}$ |
| $f_M$ Multiplexing frequency                      | $V_{SS} = 12\text{ V}$   | 0         | 800  | Hz                  |

## MODES OF OPERATION

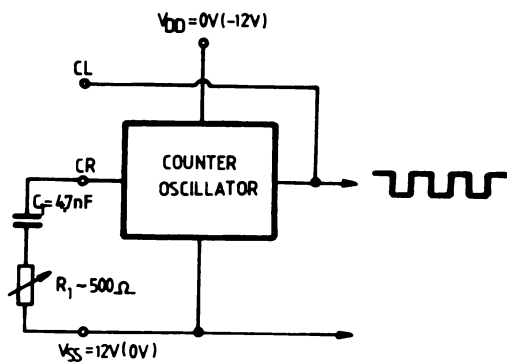

\* Input CL open

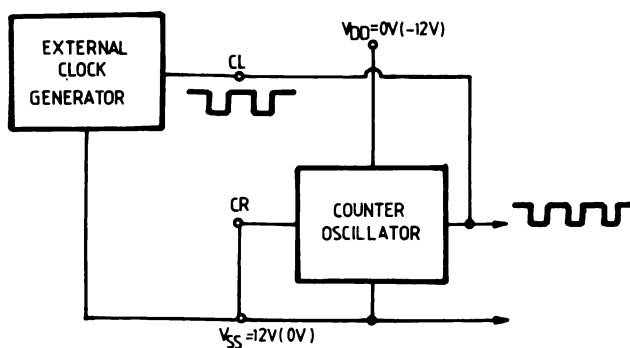

\* Input CR connected to  $V_{SS}$

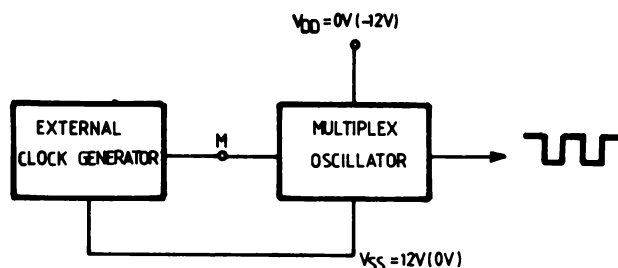
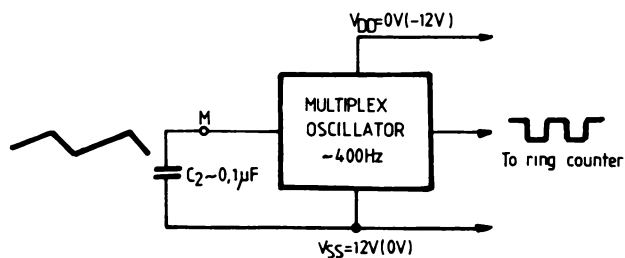

\* Only for testing purposes and  $R_1 = 0$

## FUNCTIONAL DESCRIPTION

### GENERAL

The circuit comprises the logic functions for a digital multimeter, on the basis of dual-slope method, with automatic range switching. By means of four measuring-range outputs, small units with 3 3/4 digits and four measuring ranges can be realized without additional external components for the range selection. By switching the logic range, up to eight different measuring ranges can be switched automatically; however, decoding of these ranges must be done externally.

The maximum display is 6000. 6000 steps mean a relatively small analog circuit requirement, however, that permit the measuring of voltages between 100  $\mu$ A and 600 V in four measuring ranges. When the highest measuring range is exceeded, the value 6000 is displayed. Through an additional blinking circuit, which does not require an additional connection pin, the user is made aware of the measuring range being exceeded.

### FUNCTION

The block diagram shows a simple unit with four automatically selected measuring ranges. The external analog portion consists of only the analog amplifiers, reference voltage source, and the analog switches for the measuring phase and range switching.

### BLOCK DIAGRAM

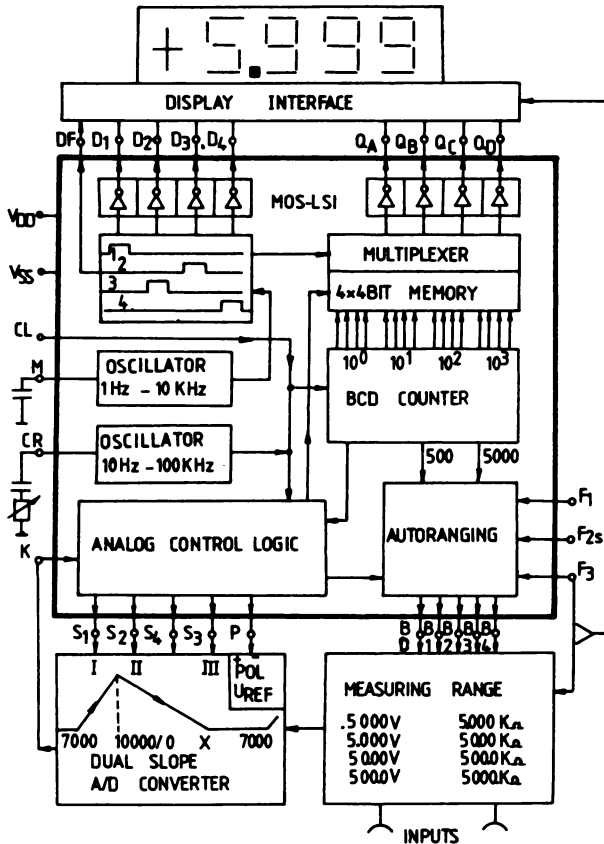

The sequence control and generation of the value measured is done by the MMP 190. The main portion of the circuit is made up of a four decade BCD counter which is driven by a counting oscillator contained on the chip, together with an externally connected RC-circuit. The counting oscillator may be replaced by connecting a clock generator. At particular periods of timing, the contents of the counter is transferred into the 4 x 4-bit memory by means of a strobe pulse derived from the K-input.

The information contained in the memory is transferred by means of a multiplexer in a bit-parallel mode to outputs  $Q_A$  through  $Q_D$ , whereby outputs  $D_1$  through  $D_4$  indicate the just transferred decimal place ( $Q_A \hat{=} \text{LSB}$ ,  $Q_D \hat{=} \text{MSB}$ ;  $D_1 \hat{=} \text{units digit}$ ,  $D_4 \hat{=} \text{thousands digit}$ , active condition = high level). To ensure reliable driving of the memories in the display interface, e.g. liquid crystal display, the correct BCD-information is maintained at the Q outputs until after the end of the active condition of the D-outputs. The indication of the decimal position occurs in the sequence 1-3-2-4, to avoid flickering when the display units are driven directly.

For the generation of scan-frequency for the multiplexer a second oscillator has been provided on the MMP 190. Replacement by an external clock generator is possible but should be used only for testing purposes. The display frequency DF of about 50 Hz required by liquid crystal displays is also derived from the multiplex oscillator.

### MEASURING-SEQUENCE

The measuring sequence is also controlled by the BCD-counter, via measuring-phase outputs  $S_1$  through  $S_4$  (compare timing diagram and principle circuit diagram).

### EXTERNAL ANALOG CIRCUIT

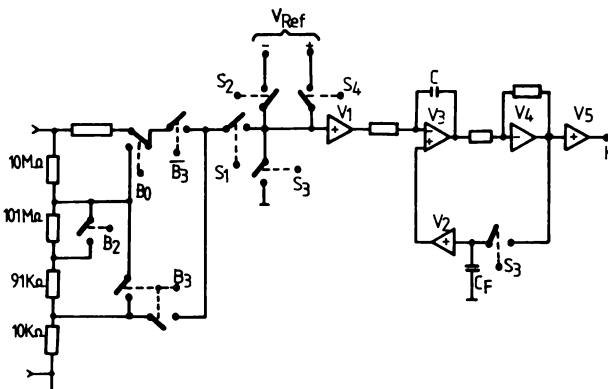

### TIMING DIAGRAM

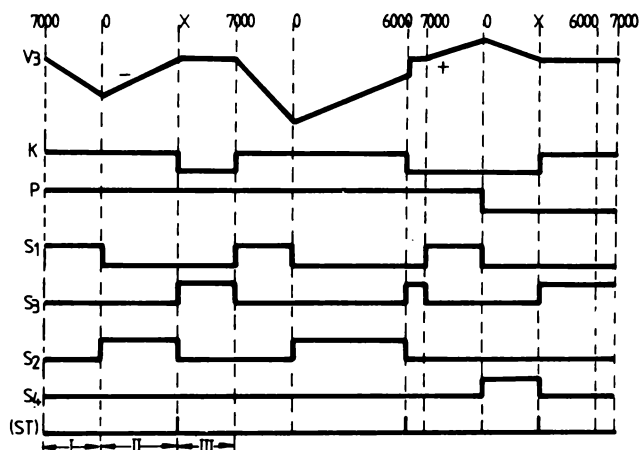

### PHASE I, INTEGRATION OF THE MEASURING VOLTAGE

The measuring cycle starts at counter position 7000; at this point output  $S_1$  becomes high, whereby the input voltage is switched to the integrator until counter position 0000 has been reached. At the moment when the counter jumps from 9999 to 0000, the signal level of the comparator (input k) is stored. At this moment phase II is started.

## PHASE II, INTEGRATION OF REFERENCE VOLTAGE

Depending on the condition of the comparator, only  $S_2$  or  $S_4$  is activated whereby the reference voltage is switched to the integrator with a polarity opposite to the previously applied input voltage. With this reference voltage the integrator is reduced until the sensitivity threshold of the comparator has been reached and the signal condition at the input K changes. This change of signal activates  $S_3$ . The number of counting pulses between counter position 0000 and X is proportional to the measuring voltage. Through the low-high transition of  $S_3$  the counter contents is loaded into the display memory; at this point of time phase III is started.

## PHASE III, ZERO REGULATION

In this process the input of the AD-converter is set to zero and the resulting error voltage is stored in capacitor  $C_F$ . An error voltage is compensated by a feedback loop. The duration of phase I is determined by the counter frequency and the fixed number of 3000 counting steps. For a 30 KHz counting frequency, phase I lasts exactly 100 ms. The longer the integration time, the better the suppression of noise voltages superimposed on the measuring signal. If the duration of the noise voltage period is contained in the integration time as an even number, this noise is suppressed completely. As noise voltages can be expected to occur especially at line frequency, 100 ms integration time constitute a favourable compromise between integration time and noise voltage suppression. The duration of phase II is determined by the level of the measuring voltage. If the measuring voltage is too large, the integrator cannot be discharged during the 6000 counting steps available as a maximum; consequently, at step 6000 phase III is initiated. Hence, the integrator will have assumed the correct starting position at the beginning of phase I which follows. For excessive measuring voltages the display is therefore 6000. In order to bring the incorrectness of this display to the user's attention, the pseudo-decade HHHH is made active at the outputs, synchronously to signal  $S_1$ ; thereby a blinking effect of approx. 3 Hz is obtained.

## AUTOMATIC RANGE SWITCHING

The measuring range is changed whenever the measuring result has been  $\geq 5500$  or  $< 500$ . For  $n \geq 5500$  the range counter (3 bit up/down counter) is stepped by one count, for  $n < 500$  stepped down by one, whereby the counter is blocked on the lowest or highest digit position, respectively. The range selection can be controlled through control inputs  $F_1$ ,  $F_{25}$  and  $F_3$ .

## TRUTH TABLE

| Nr | Q3 | Q2 | Q1 | F1 | F25 | F3 | B0 | B1 | B2 | B3 | B4 |
|----|----|----|----|----|-----|----|----|----|----|----|----|
| 0  | L  | L  | L  | L  | L   | L  | H  |    |    |    |    |
| 1  | L  | L  | H  | L  | L   | L  |    | H  |    |    |    |
| 2  | L  | H  | L  | L  | L   | L  |    |    | H  |    |    |
| 3  | L  | H  | H  | L  | L   | L  |    |    |    | H  |    |
| 4  | H  | L  | L  | L  | L   | L  |    |    |    | H  | H  |
| 5  | H  | L  | H  | L  | L   | L  |    |    |    | H  | H  |
| 6  | H  | H  | L  | L  | L   | L  |    |    |    | H  | H  |
| 7  | H  | H  | H  | L  | L   | L  |    |    |    | H  | H  |
| 10 | L  | L  | L  | H  | L   | L  |    | H  |    |    |    |
| 11 | L  | L  | H  | H  | L   | L  |    | H  |    |    |    |
| 12 | L  | H  | L  | H  | L   | L  |    |    | H  |    |    |
| 13 | L  | H  | H  | H  | L   | L  |    |    |    | H  |    |
| 14 | H  | L  | L  | H  | L   | L  |    |    |    |    | H  |
| 15 | H  | L  | H  | H  | L   | L  |    |    |    |    | H  |
| 16 | H  | H  | L  | H  | L   | L  |    |    |    |    | H  |
| 17 | H  | H  | H  | H  | L   | L  |    |    |    |    | H  |
| 2X | Q3 | Q2 | Q1 | X  | H   | L  | X  | Q1 | X  | Q2 | Q3 |
| 30 | H  | H  | H  | L  | L   | H  |    |    |    | H  | H  |
| 31 | H  | H  | H  | H  | L   | H  |    |    |    |    | H  |
| 32 | H  | H  | H  | X  | H   | H  | X  | H  | X  | H  | H  |

When the control inputs  $F_1$ ,  $F_{2S}$  and  $F_3$  are in a low condition, the counter can move within the lower 5 positions up or down. Should it be in a higher position, it can step only downward until the "free zone" has been reached; the decoder produces correct values also for counter positions outside the "free zone" so that the system adjusts itself.

By an H-signal at input  $F_1$  the correlation between the counter position and decoder output can be changed. Thereby it is made possible to perform range setting for the voltage and resistance ranges and the control of the decimal point in a simple unit with four measuring ranges without external decoding. Input  $F_3$  is used to set the counter to the highest level. The highest measuring range is activated and maintained as long as  $F_2$  is kept at a high level. For example, thereby the range 500.0V is activated, which is an advantage for quick overview-measurements.

A high level at input  $F_{2C}$  has the effect that the outputs of the range counter are directly transferred to the outputs 8 different ranges are then available which must be decoded by external means. In the case of  $F_{2S} = H$ , the "free zone" of the counter is expanded to the full counting range; the prevention of "running wild" is maintained.

### THE TRUTH TABLE FOR SETTING THE MEASURING RANGES SHOULD BE UNDERSTOOD AS FOLLOWS:

The range outputs  $B_0...B_4$  are intended to directly drive the five possible decimal places of a 4 decade display. Simple units with 4 measuring ranges have been taken into consideration. For example, in the case of voltages the measuring ranges with  $F_1 = \text{low}$  are:

|       |         |
|-------|---------|
| $B_0$ | .5000 V |
| $B_1$ | 5.000 V |
| $B_2$ | 50.00 V |
| $B_3$ | 500.0 V |

The total measuring range therefore comprises 0.1 mV through 599.9 V. For resistance measuring, however,  $F_1$  must be high:

|       |            |
|-------|------------|
| $B_1$ | 5.000 kohm |
| $B_2$ | 50.00 kohm |
| $B_3$ | 500.0 kohm |
| $B_4$ | 5000. kohm |

The total measuring therefore comprises 1 ohm through 5.999 Mohm. Hence, using control input  $F_1$ , a choice of one of the two groups is basically possible.

The range outputs are also intended to directly drive the appropriate four selection relays without additional logic gating. When the automatic range selection (e.g. after turn-on) has not yet found the correct range, some measuring range expected to be shown anyway. This side-condition is considered in the truth table of vectors 0...17.

It should be noted, however, that  $Q_1$ ,  $Q_2$ , and  $Q_3$  in the truth table are internal outputs of the built-in up-down counter. It is also possible to select one of 5 measuring ranges automatically. To do this, the 4th and the 5th measuring ranges are separated by external gating at  $F_1 = \text{low}$  (whereby  $MB_4 = B_3$ ;  $B_4$  and  $MB_5 = B_4$ ).  $MB_4$  is measuring range 4,  $MB_5$  is measuring range 5.

$F_{2S} = \text{high}$  causes an extension of all eight possible measuring ranges. The range selected appears at outputs  $B_1 (=Q_1)$ ,  $B_3 (=Q_2)$ , and  $B_4 (=Q_3)$  dual-coded. Hence, vectors 20...27 of the truth table are fixed.



# 5-STAGE STATIC SHIFT REGISTER SYNCHRONOUS PARALLEL OR SERIAL INPUT/PARALLEL OUTPUT

## GENERAL DESCRIPTION

MMP 311 contains one 5-stage shift register synchronous parallel or serial input/parallel output, having two external clocks, a single serial data input, a parallel control input and individual parallel inputs to each register stage.

Each register stage is a quasi-static D-type master-slave flip-flop. When  $\emptyset 1$  is static on "HIGH" and  $\emptyset 2$  is "LOW" each stage becomes a static memory cell, and the logic level present at each data input  $I_i$  is immediately transferred to the data output  $O_i$ . When the two external clocks are applied, and the parallel control input,  $I_p$  is "HIGH" data is serially shifted into the 5-stage register, from  $I_5$  to  $O_1$ . When  $I_p \cdot \emptyset 2 =$  "LOW" and  $\emptyset 1 =$  "HIGH" data is jammed into the 5-stage register and remains unaffected as long as  $\emptyset 1$  is "HIGH". Data is serially shifted with the negative transition of the  $\emptyset 1$  clock line.

## ABSOLUTE MAXIMUM RATINGS

|          |                       |            |    |
|----------|-----------------------|------------|----|
| $V_{DD}$ | Supply voltage        | -31...0.3  | V  |
| $V_o$    | Clock input voltage   | -31...0.3  | V  |
| $V_i$    | Data input voltage    | -25...+0.3 | V  |
| $T_{op}$ | Operating temperature | 0...70     | °C |
| $T_{ST}$ | Storage temperature   | -55...+85  | °C |

## RECOMANDED OPERATING CONDITIONS

|          |                |               |   |
|----------|----------------|---------------|---|
| $V_{DD}$ | Supply voltage | $-13 \pm 0.5$ | V |
| $V_o$    | Clock voltage  | $-26 \pm 2$   | V |

## PIN CONNECTIONS

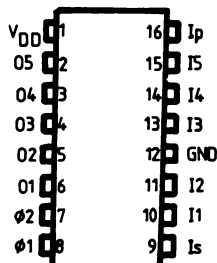

**STATIC ELECTRICAL CHARACTERISTICS •**

| PARAMETER     | TEST CONDITIONS               | VALUES |      |      | UNIT    |
|---------------|-------------------------------|--------|------|------|---------|
|               |                               | min.   | typ. | max. |         |
| $I_{LI}$      | data input quiescent current  |        |      | 10   | $\mu A$ |
| $I_{L\phi 1}$ | clock input quiescent current |        |      | 50   | $\mu A$ |
| $I_{L\phi 2}$ | clock input quiescent current |        |      | 1    | mA      |
| $V_{OL}$      | output low voltage            |        |      | -10  | V       |
| $V_{OH}$      | output high voltage           |        | -1   |      | V       |
| $V_{OL}$      | output low voltage            |        |      | -5   | V       |
| $V_{OH}$      | output high voltage           |        | -3   |      | V       |

**DYNAMIC ELECTRICAL CHARACTERISTICS •**

| PARAMETER  | TEST CONDITIONS   | VALUES |      |      | UNIT |
|------------|-------------------|--------|------|------|------|
|            |                   | min.   | typ. | max. |      |
| $t_{THL}$  | transition time   |        | 400  |      | ns   |
| $t_{TLH}$  | transition time   |        | 600  |      | ns   |
| $f_{\phi}$ | clock frequency   |        |      | 500  | KHz  |
| $C_i$      | input capacitance |        |      | 4    | pF   |

• (over recommended operating conditions)

**SCHEMATIC DIAGRAM**

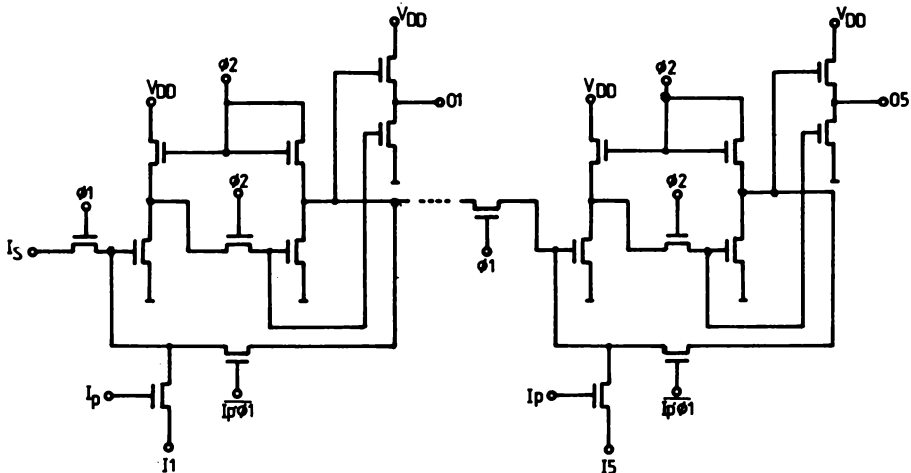

# 8 CHANNEL TOUCH CONTROL CIRCUIT FOR TV PROGRAM SELECTION

## GENERAL DESCRIPTION

The MMP 710 circuit is used as input circuit together with the MMP 714 decoder circuit for electronic touch plate switching of 8 or 16 channels for TV program selection.

The MMP 710 circuit contains a 3 bit counter in p-channel high voltage technology. By any of the 8 inputs  $I_1$  to  $I_8$  it can be fixed in each state (parallel operation). The serial operation is accomplished on the H-L transitions of the clock pulse from the  $I_S$  input (clock impulses input). The binary coded output information is obtained from the push-pull output stages. When power-on, the counter is set on the 1 preferential state (HHH). In this basic operating mode the  $I_{CL}$  connection is tied to the  $V_{DD}$  potential and O4 to that of the background,  $V_{SS}$ . A 4 bit counter can be obtained by interconnecting 2 MMP 710 circuits. In this connection O4 has a combined input-output function. It controls by flip-flopping the operation of the 2 connected circuits. The disconnection of one of the 2 circuits is made by an internal connecting logic.

In this situation the  $I_{CL}$  connection of the first circuit is tied to the  $V_{DD}$  potential while that of the second circuit is tied to the background. The O1 ... O4 outputs and the  $I_S$  inputs of the 2 circuits are connected together.

All inputs are provided with integrated protective diodes.

The circuit is delivered in a 16 lead dual-in line plastic package..

## FEATURES

- Parallel and serial operation modes
- Preferential output state at power-on
- Input protective diodes

## ABSOLUTE MAXIMUM RATINGS

( $T_A = 0$  to  $70^\circ\text{C}$ )

|          |                                     |  |
|----------|-------------------------------------|--|
| $V_{DD}$ | Supply voltage relative to $V_{SS}$ | -31V to 0.3V                               |
| $V_I$    | Input voltage relative to $V_{SS}$  | -25V to 0.3V                               |
| $T_A$    | Operating ambient temperature       | $0^\circ\text{C}$ to $70^\circ\text{C}$    |
| $T_C$    | Storage temperature                 | $-55^\circ\text{C}$ to $125^\circ\text{C}$ |

## PIN CONNECTIONS

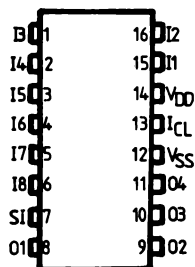

## PIN NAMES

|          |  |
|----------|--|
| I1 I8    | PARALLEL INPUTS  |
| SI       | SERIAL INPUT   |
| O1 O4    | OUTPUTS  |
| ICL      | INTERNAL CONNECTING LOGIC CONTROL  |
| $V_{DD}$ | POWER SUPPLY ( $-27$ $\begin{smallmatrix} -1 \\ +2 \end{smallmatrix}$ V) |
| $V_{SS}$ | GROUND   |

## BLOCK DIAGRAM

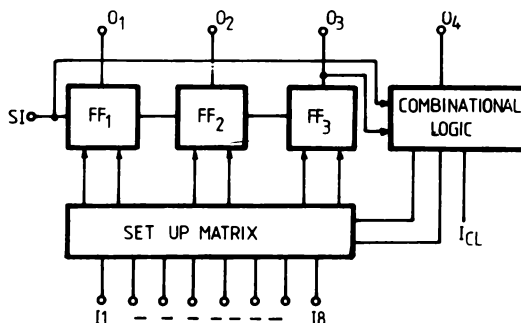

## ELECTRICAL CHARACTERISTICS

 $(-V_{DD} = 27_{-2}^{+1} \text{ V}, T_A = 25^\circ\text{C})$ 

| PARAMETER                     | TEST CONDITION        | VALUES |     | UNIT          |
|-------------------------------|-----------------------|--------|-----|---------------|
|                               |                       | min    | max |               |
| $-I_1$ Input leakage current  | $-V_1 = 25\text{V}$   |        | 10  | $\mu\text{A}$ |
| $-V_{IH}$ Input high voltage  |                       |        | 2   | V             |
| $-V_{IL}$ Input low voltage   |                       | 9      |     | V             |
| $-V_{OH}$ Output high voltage | $R_L = 100 \text{ k}$ |        | 1   | V             |
| $V_{OH}$                      | $-I_0 = 1 \text{ mA}$ |        | 3   | V             |
| $-V_{OL}$ Output low voltage  | $R_L = 100 \text{ k}$ | 10     |     | V             |
| $V_{OL}$                      | $-I_0 = 1 \text{ mA}$ | 9      |     | V             |
| $-I_1$ Supply current         | $I_0 = 0$             |        | 2.3 | mA            |

## OUTPUT DATA

| STATE | OUTPUT DATA    |                |                |                |
|-------|----------------|----------------|----------------|----------------|
|       | O <sub>1</sub> | O <sub>2</sub> | O <sub>3</sub> | O <sub>4</sub> |
| 1     | H              | H              | H              | H              |
| 2     | L              | H              | H              | H              |
| 3     | H              | L              | H              | H              |
| 4     | L              | L              | H              | H              |
| 5     | H              | H              | L              | H              |
| 6     | L              | H              | L              | H              |
| 7     | H              | L              | L              | H              |
| 8     | L              | L              | L              | H              |
| 9     | H              | H              | H              | L              |
| 10    | L              | H              | H              | L              |
| 11    | H              | L              | H              | L              |
| 12    | L              | L              | H              | L              |
| 13    | H              | H              | L              | L              |
| 14    | L              | H              | L              | L              |
| 15    | H              | L              | L              | L              |
| 16    | L              | L              | L              | L              |

**TYPICAL APPLICATIONS**

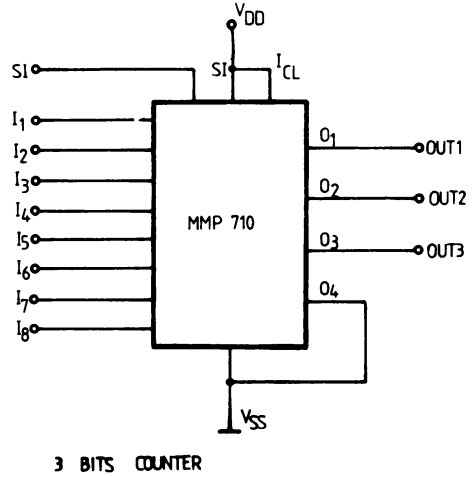
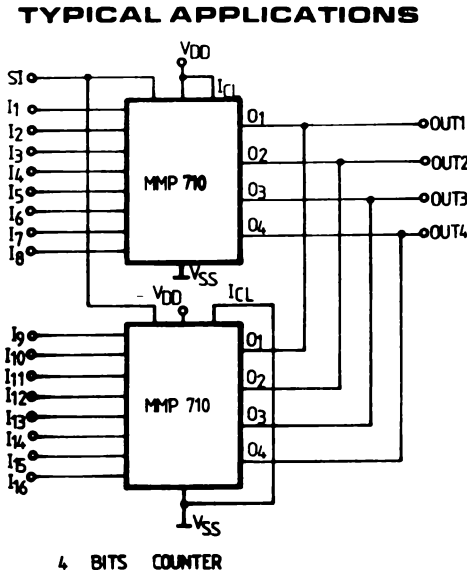

**INPUT CONNECTING TO TOUCH PLATES**

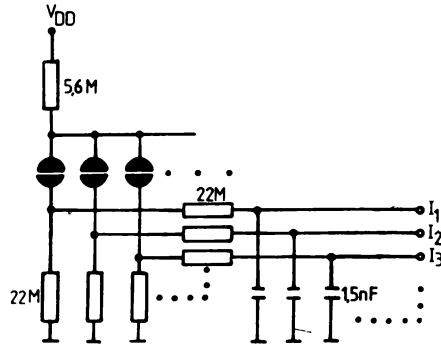

**CLOCK PULSE CHARACTERISTICS**

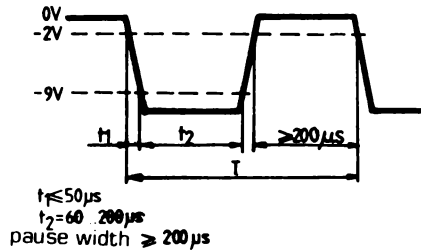

# 1 OF 8 BINARY DECODER

## GENERAL DESCRIPTION

The MMP 711 is a 1 of 8 binary decoder manufactured in PMOS-AI gate high voltage technology.

MMP 711 together with MMP 710 can be used as output circuit for TV switch channels (8 or 16 channels).

The binary input information from the 4 inputs is transferred to the decoding matrix. In this basic operation mode the  $I_{CL}$  connexion is tied to  $V_{DD}$  and  $I_4$  to the background potential ( $V_{SS}$ ).

Assembling together two MMP 711 integrated circuits to form a 1 of 16 binary decoder needs with the proper connection of the input  $I_{CL}$ .

In this case the input  $I_{CL}$  of the first circuit (1...8) is tied to  $V_{DD}$  and the input  $I_{CL}$  of the second circuit (9...16) to the background potential ( $V_{SS}$ ).

The inputs  $I_1...I_4$  of both circuits are tied together.

The MMP 711 is supplied in a 16 lead dual in line plastic package.

## FEATURES

- The outputs consist of open drain transistors.
- All inputs are protected against static charge.

## ABSOLUTE MAXIMUM RATINGS

|           |                               |              |    |
|-----------|-------------------------------|--------------|----|
| $V_{DD}$  | Supply Voltage                | -31 ... +0.3 | V  |
| $V_I$     | Input Voltage                 | -25 ... +0.3 | V  |
| $I_D$     | DC Output Current             | - 3          | mA |
| $T_A$     | Operating Ambient Temperature | 0 ... +70    | °C |
| $T_{stg}$ | Storage Temperature           | -55 ... +125 | °C |

## PIN CONNECTIONS

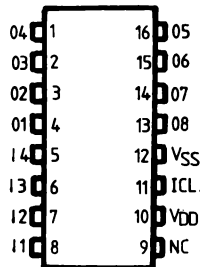

## BLOCK DIAGRAM

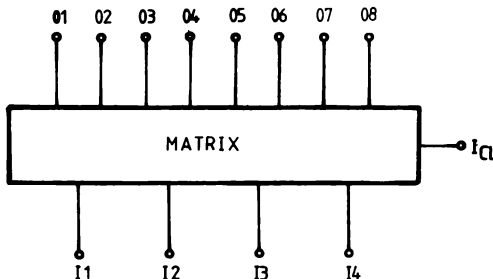

**ELECTRICAL CHARACTERISTICS**

( $-V_{DD} = 27_{-2}^{+1}$  V,  $T_A = 25^\circ\text{C}$ ) unless otherwise specified

| PARAMETER   | TEST CONDITION   | VALUES |     | UNIT                               |
|---|--|--------|-----|------------------------------------|
|   |  | min    | max |                                    |
| $-V_{IH}$ Input High Voltage  | $R_L = 100\text{ K}$<br>$-I_o = 3\text{ mA}$<br>$I_o = 0$    | 9      | 2   | V                                  |
| $-V_{IL}$ Input Low Voltage   |  |        |     | V                                  |
| $-V_{OH}$ Output High Voltage   |  |        | 0.5 | V                                  |
| $-V_{OL}$ Output Low Voltage  |  |        | 2   | V                                  |
| $-I_{DD}$ $V_{DD}$ Supply Current   |  |        | 0.6 | mA                                 |
| $\frac{\Delta(V_{DD}-V_{OH})}{\Delta T_A}$ Output High Voltage Differential Drift | $T_A = 10\text{...}50^\circ\text{C}$<br>$R_L = 100\text{ K}$ |        | 1   | $\frac{\text{mV}}{^\circ\text{C}}$ |

**OUTPUT CONNECTING**

Used together with the MMP 710 for electronic touch plate switching of programs for television receivers.

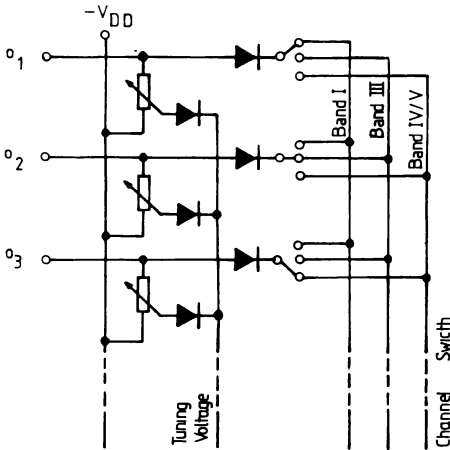

**DECODER INPUT DATA**

| STATE | OUTPUT DATA |       |       |       |
|-------|-------------|-------|-------|-------|
|       | $I_1$       | $I_2$ | $I_3$ | $I_4$ |
| 1     | H           | H     | H     | H     |
| 2     | L           | H     | H     | H     |
| 3     | H           | L     | H     | H     |
| 4     | L           | L     | H     | H     |
| 5     | H           | H     | L     | H     |
| 6     | L           | H     | L     | H     |
| 7     | H           | L     | L     | H     |
| 8     | L           | L     | L     | H     |
| 9     | H           | H     | H     | L     |
| 10    | L           | H     | H     | L     |
| 11    | H           | L     | H     | L     |
| 12    | L           | L     | H     | L     |
| 13    | H           | H     | L     | L     |
| 14    | L           | H     | L     | L     |
| 15    | H           | L     | L     | L     |
| 16    | L           | L     | L     | L     |

**TYPICAL APPLICATIONS**

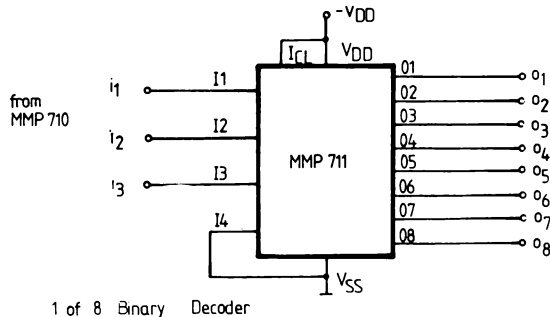

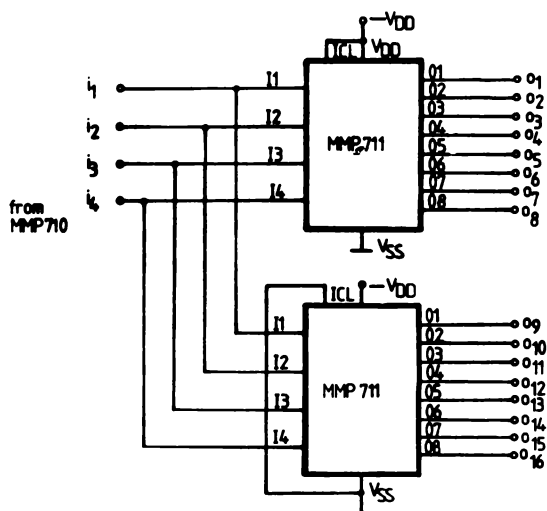

1 of 16 Binary Decoder



# 4-DIGIT COUNTER / DISPLAY DECODER

## GENERAL DESCRIPTION

The MMP 5002/5/7 is an ion-implanted, P-channel MOS, four-decade synchronous counter with latches, multiplexing circuits, and a read-only memory programmed for seven-segment outputs and BCD outputs. In addition many on-chip control circuits provide flexibility of use with a minimum of external components.

The MMP 5002/5/7 provides a means of counting up to 9999, transferring the count into latches without interrupting the counting operation, and supplying the latched information to the outputs one decade at a time. Scanning is controlled by the SCAN input which increments a one-of-four counter on its negative edge, thereby scanning the latches from MSD (Most Significant Digit) to LSD (Least Significant Digit).

Low-threshold voltages for input DTL/TTL compatibility are achieved through the ion-implantation process. Enhancement mode devices as well as depletion-mode devices, are fabricated on the chip, allowing it to operate from a single +5 V power supply. Depletion-mode technology also allows the entire circuit to operate on less than 25 mW of power. The

block diagram, shows all options available on the MMP 5002/5/7. Other members of this family which are different versions of this same chip are the MMP 5005 and MMP 5007. The MMP 5005 is supplied in a 24-pin package and does not include the BCD outputs. The MMP 5007 is supplied in a 16-pin package.

## FEATURES

- Single-supply operation or double-supply for higher output drive
- Multiplexed seven-segment and/or BCD outputs
- TTL-compatible inputs
- Four decades of synchronous counting
- Minimum external component count
- Low power consumption

## ABSOLUTE MAXIMUM RATINGS

Absolute Maximum  $V_{SS}$

$V_{GG}$  Supply Range

Operating Temperature Range

7.5 V

0V  $V_{GG}$  -13.2 V

0°C  $T_A$  75°C

## PIN CONNECTIONS

### MMP 5002

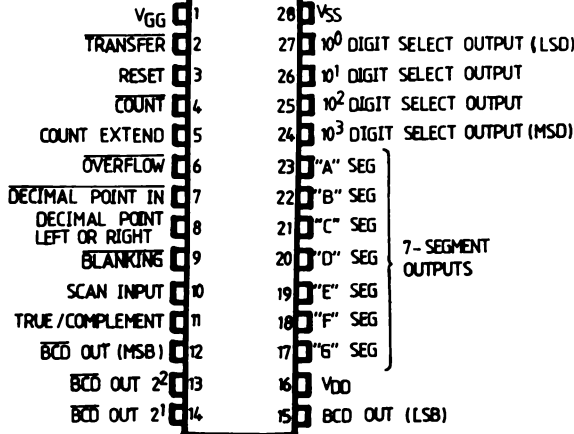

### MMP 5005

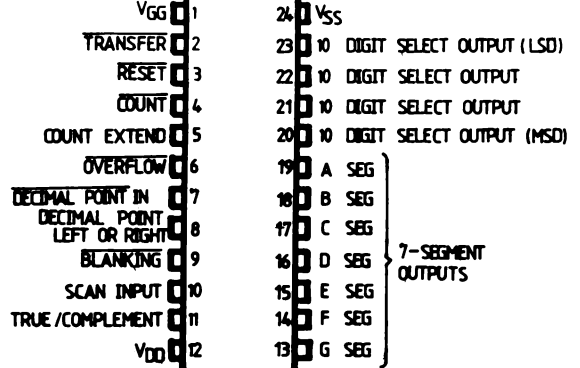

### MMP 5007

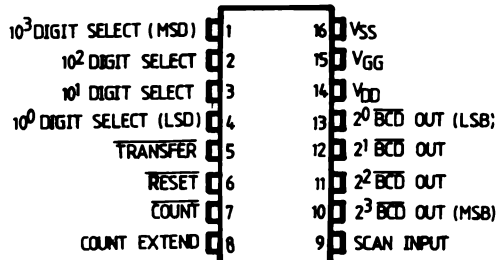

## RECOMANDED OPERATING CONDITIONS

| PARAMETER                       | TEST CONDITIONS                  | VALUES |      |                 | UNITS | NOTES |
|---------------------------------|----------------------------------|--------|------|-----------------|-------|-------|
|                                 |                                  | min.   | typ. | max.            |       |       |
| V <sub>SS</sub> Supply voltage  | V <sub>SS</sub> —V <sub>DD</sub> | 4.5    | 5.0  | 7.5             | V     | 1.2   |
| V <sub>GG</sub> Supply voltage  | V <sub>GG</sub> —V <sub>DD</sub> | -13.2  | -12  | V <sub>DD</sub> | V     | 1.2   |
| F <sub>CI</sub> Count frequency |                                  | dc     |      | 250             | kHz   |       |

## STATIC ELECTRICAL CHARACTERISTICS

(V<sub>SS</sub> = +5 V ±5%; V<sub>GG</sub> = V<sub>DD</sub> = 0 V; 0° ≤ T<sub>A</sub> ≤ 70°C unless otherwise noted)

| PARAMETER                                       | VALUES               |                 |                      | UNITS | NOTES  |
|---|----------------------|-----------------|----------------------|-------|--|
|   | min.                 | typ.            | max.                 |       |  |
| V <sub>IL</sub> Input voltage, logic "0" (Low)  |                      | V <sub>DD</sub> | V <sub>DD</sub> +0.8 | V     |  |
| V <sub>IH</sub> Input voltage, logic "1" (High) | V <sub>SS</sub> -1   | V <sub>SS</sub> | V <sub>SS</sub> +0.3 | V     | 3  |
| I <sub>SS</sub> Supply current, V <sub>SS</sub> |                      | 2.5             | 5.0                  | mA    | 4, Inputs open   |
| I <sub>GG</sub> Supply current, V <sub>GG</sub> |                      | 0.2             | 0.5                  | mA    | V <sub>GG</sub> = -12 V  |
| C <sub>IN</sub> Input capacitance               |                      | 3               | 10                   | pF    | T <sub>A</sub> = 25°C; f = 1 MHz,<br>V <sub>IN</sub> = V <sub>SS</sub> |
| I <sub>IL</sub> Input current, logic "0"        | Count input          |                 | 1.6                  | mA    | 5  |
|   | Scan input           |                 | 1.6                  | mA    | 5  |
|   | Decimal point input  |                 | 1.0                  | μA    |  |
|   | Other logic inputs   |                 | 1.0                  | mA    |  |
| I <sub>OL</sub> Output current, logic "0"       | 0.5                  |                 |                      | mA    | 6, V <sub>GG</sub> = -12 V   |
| I <sub>OH</sub> Output current, logic "1"       | 0.5                  |                 |                      | mA    | 6, V <sub>GG</sub> = -12 V   |
| V <sub>OL</sub> Output voltage, logic "0"       |                      |                 | V <sub>DD</sub> +0.2 | V     | 4  |
| V <sub>OH</sub> Output voltage, logic "1"       | V <sub>SS</sub> -0.2 |                 |                      | V     | 4  |

## DYNAMIC ELECTRICAL CHARACTERISTICS

(V<sub>SS</sub> = +5V ±5%; V<sub>GG</sub> = V<sub>DD</sub> = 0 V; 0° ≤ T<sub>A</sub> ≤ 70°C unless otherwise noted)

| PARAMETER                                   | VALUES               |      |      | UNITS | NOTES |   |
|---|----------------------|------|------|-------|-------|---|
|   | min.                 | typ. | max. |       |       |   |
| f <sub>CI</sub> —Count input frequency      | dc                   |      | 250  | kHz   |       |   |
| f <sub>SI</sub> —Scan input frequency       | dc                   |      | 50   | kHz   |       |   |
| t <sub>RII</sub> Reset to any output delay  |                      |      | 15   | μs    |       |   |
| t <sub>PW</sub> Logic "0", Pulse width,     | Reset input          | 1.0  |      |       |       |   |
|   | Count input          | 1.0  |      |       |       |   |
|   | Scan input           | 10.0 |      |       | μs    |   |
|   | Transfer input       | 2.5  |      |       |       |   |
| t <sub>PH</sub> Logic "1" time,             | Count input          | 3.0  |      |       | μs    |   |
|   | Scan input           | 10.0 |      |       |       |   |
| t <sub>SD</sub> Scan to output disable time | Digit select outputs |      |      | 15    | μs    | 7 |
|   | All data outputs     |      |      | 15    |       | 7 |
| t <sub>SE</sub> Scan to output enable time  | Digit select outputs |      |      | 15    | μs    | 8 |
|   | All data outputs     |      |      | 15    |       | 8 |

| PARAMETER  | VALUES |      |      | UNITS         | NOTES |
|--|--------|------|------|---------------|-------|
|  | min.   | typ. | max. |               |       |
| $t_{CE}$ Count input to count extend delay to 1 or 0 |        |      | 15   | $\mu\text{s}$ | 9     |
| $t_{OF}$ Count input to overflow delay (ON)          |        |      | 15   | $\mu\text{s}$ | 9     |
| $t_{ROF}$ Reset input to overflow delay (OFF)        |        |      | 5    | $\mu\text{s}$ |       |

**NOTES**

- $V_{DD} = 0\text{ V}$
- $V_{SS} - V_{GG}$  no more than 20.7 V
- Internal pull-up resistors (aprox. 10 K) are provided at all inputs other than Count input, Scan input, and Decimal point input
- $V_{GG} = -12\text{ V} \pm 10\%$ . Outputs open
- Measurement made at  $V_I = V_{DD} + 0.4\text{ V}$ . This condition is sufficient to represent a logic 0 and hold off or override the internal oscillators. Maximum current at  $V_I = +0.4\text{ V}$  is 1.6 mA. 400  $\mu\text{A}$  source current at  $V_{SS} - 1.0\text{ V}$  is sufficient to represent a logic "1" and hold off or override the internal oscillators.
- $I_{OL}$  measured at  $V_O = V_{SS} - 0.75\text{ V}$  (Direct driving base npn emitter to  $V_{SS}$ )  
 $I_{OH}$  measured at  $V_O = V_{DD} + 0.75\text{ V}$  (Direct driving base npn emitter to  $V_{DD}$ )
- Delay measured from the negative edge of the SCAN input.
- Delay measured from the rising edge of the SCAN input.
- Delay measured from the negative edge of the COUNT input.

**FUNCTIONAL DESCRIPTION** **$V_{GG}$ , Pin 1**

$V_{GG}$  is the output gate drive voltage supply which is no greater than  $V_{DD}$  and no less than  $V_{DD} - 13.2\text{ V}$ . Higher output drive capability is realized when  $V_{GG}$  is maintained at the recommended level of  $V_{DD} - 12\text{ V}$ .

 **$\overline{\text{TRANSFER}}$ , Pin 2**

While  $\overline{\text{TRANSFER}}$  is at logic 0, data in the decade counters is continuously transferred to the latches. This input may be left at 0 for a continuous transfer and display mode or may be driven high to subsequently cause the latches to store the current counter contents. Storage occurs internally when  $\overline{\text{TRANSFER}}$  is taken to a 1 and the next negative edge of  $\overline{\text{COUNT INPUT}}$  occurs. This allows asynchronous  $\overline{\text{COUNT}}$  and  $\overline{\text{TRANSFER}}$  operation since the transfer is terminated internally prior to incrementing the counters. This means that a  $\overline{\text{COUNT}}$  negative edge must follow a  $\overline{\text{TRANSFER}}$  command before a reset is applied to assure transfer of valid data. An external reset command must be delayed at least one  $\overline{\text{COUNT}}$  negative edge following a transfer. External transfer should terminate at least 1  $\mu\text{s}$  prior to this  $\overline{\text{COUNT}}$  negative edge and  $\overline{\text{RESET}}$  should occur no sooner than 1  $\mu\text{s}$  following that edge.

 **$\overline{\text{RESET}}$ , Pin 3**

The decade counters are reset to 0000 when  $\overline{\text{RESET}}$  is at logic 0. The  $\overline{\text{RESET}}$  input at logic 0 also forces the scan counter to the MSD output and resets the  $\overline{\text{OVERFLOW}}$  latch output to a logic 1. It maintains this condition as long as a logic 0 is present at  $\overline{\text{RESET}}$  and overrides all other associated inputs. As indicated previously, the decade counters should not be reset until a transfer has been terminated.

Since the  $\overline{\text{RESET}}$  input resets the scan counter to the MSD, the scan rate must be much faster than the reset rate to allow the lesser significant digits to be enabled. Therefore,  $F_{\text{SCAN}}$  should be much greater than four times  $f_{\text{RESET}}$ .

Ideally, the reset pulse should also be made narrow to prevent its duration from causing the MSD to be on much longer than the other digits and thus appear to be brighter.

 **$\overline{\text{COUNT}}$ , Pin 4**

The decade counters are synchronously incremented on the negative edge of the  $\overline{\text{COUNT}}$  input. The internal oscillator on this input may be overridden by an external signal source or may be allowed to oscillate at a frequency set by a single capacitor tied to this input from the  $V_{SS}$  or  $V_{DD}$  supply. In systems with considerable noise, better oscillator stability exists when the capacitor is tied to  $V_{SS}$ .

**COUNT EXTEND, pin 5**

COUNT EXTEND is a feature provided to enable MMP 5002s to be cascaded. Whenever the counter state attains 9999 count, the COUNT EXTEND output goes high. This output remains logical 1 only the next negative transition of COUNT OCCURS or a RESET signal is applied.

**OVERFLOW, Pin 6**

OVERFLOW occurs on the 10,000th count input following a reset. It is normally high and, when activated, goes low to indicate that the decade counters have gone from 9999 to 0000 without encountering a reset. Once activated, the OVERFLOW latch will remain low until RESET is pulled low.

**DECIMAL POINT IN, Pin 7**

With DECIMAL POINT IN held high, the device employs leading zero blanking. This causes any leading zeros in the display latches to be blanked when their DIGIT SELECT goes high. At the start of each MSD to LSD scan, blanking of leading zeros occurs until the first non-zero number occurs in the display or DECIMAL POINT IN is clocked to a 0. Any number following will be displayed. Leading zero blanking does not affect the BCD outputs or the LSD in the Display which is displayed even if zero. The LSD output resets the blanking circuitry to begin blanking zeros in the next scan cycle.

Leading zero blanking may be inhibited by wiring DECIMAL POINT IN to ground. The MMP 5007 does not have a pin for DECIMAL POINT IN and therefore does not have leading zero blanking.

In the DECIMAL POINT RIGHT mode, even though the DECIMAL POINT IN is clocked, unblanking is delayed until the following digit is enabled.

**DECIMAL POINT LEFT OR RIGHT, Pin 8**

Bringing this control to logic 1 allows the use of displays with the decimal point physically located on the left side of the numeral.

Logic 0 on this input allows for a right-handed decimal point.

**BLANKING, Pin 9**

The BLANKING input at logic 0 forces the 7-segment outputs to the off-state and the BCD to the equivalent of the number zero. This condition is maintained on a dc basis as long as the BLANKING input is zero. The DIGIT SELECT outputs continue to operate at the scan rate as described.

**SCAN INPUT, Pin 10**

The DIGIT SELECT COUNTER is incremented by a negative edge on the SCAN INPUT. During the time the SCAN INPUT is at 0, the SEGMENT and DIGIT SELECT outputs are forced off and the complement BCD outputs are forced to logic 1. The off level of the 7-segment and BCD outputs is determined by the state of the TRUE/COMPLEMENT input. This remains until the SCAN INPUT returns to logic 1.

The DIGIT SELECT COUNTER is a one-of-four counter, scanning from MSD to LSD, enabling one quad latch output at a time, and presenting a logic 1 to the corresponding DIGIT SELECT output.

The internal oscillator on this input may be overridden by an external signal source or may be allowed to oscillate at a frequency set by a single capacitor tied to this input from the  $V_{SS}$  or  $V_{DD}$  supply. In systems with considerable noise better oscillator stability exists when the capacitor is tied to  $V_{SS}$ .

**TRUE/COMPLEMENT, Pin 11**

When this control is driven to 0, inversion of both the BCD and 7-segment outputs occurs. Depending upon the display used, combinations of the BLANKING input and TRUE/COMPLEMENT control can be chosen to give a lamp test.

**BCD OUT, Pins 12 through 15**

The BCD outputs are push-pull and are designed to drive directly to the base of common emitter transistors.

 **$V_{DD}$ , Pin 16**

$V_{DD}$  is the negative supply and is nominally ground.

**SEGMENT OUTPUTS, Pins 17 through 23**

The SEGMENT OUTPUT buffers are identical to the BCD output buffers.

**DIGIT SELECT OUTPUTS, Pins 24 through 27**

The DIGIT SELECT OUTPUTS are push-pull and go high during their appropriate times to accomplish the multiplexing of the digits.

**V<sub>SS</sub>, Pin 28**

V<sub>SS</sub> is the positive supply voltage and is nominally maintained at 5 Vdc with respect to V<sub>DD</sub>.

**BLOCK DIAGRAM**

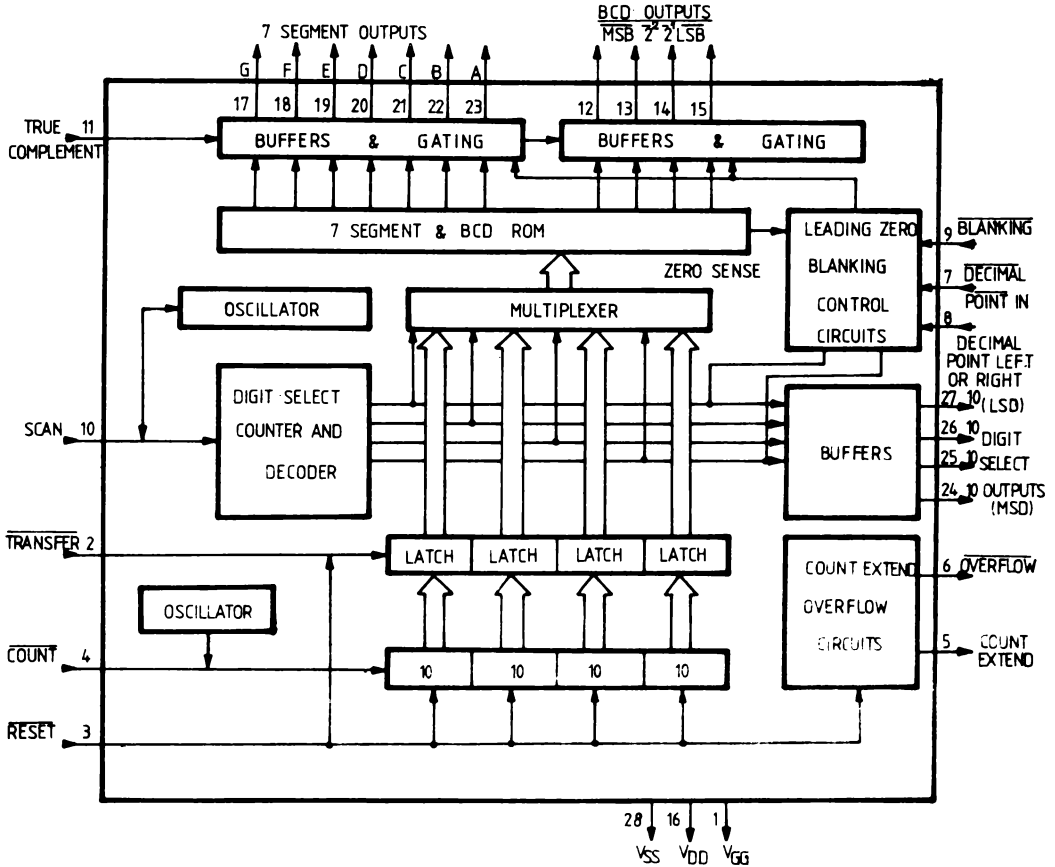

# COUNTER TIME - BASE CIRCUIT

## GENERAL DESCRIPTION

The MMP 5009 is a highly versatile MOS oscillator and divider chain manufactured in the depletion-load ion implantation process and P-channel technology. The 16-pin DIP package provides frequency division ranges from 1 to  $36 \times 10^8$ . The circuit will operate from any of three frequency sources: the internal oscillator with an external RC combination; the internal oscillator with an external crystal; or with an externally-applied TTL signal. Control inputs provide additional versatility and allow the circuit to be used in a variety of applications including instruments, timers and clocks.

The MMP 5009 consists basically of a series of counters, selectable via an internal multiplexer. The  $\div 10^1$  counter output is used to generate an internal clock signal for the  $10^2$  through  $36 \times 10^8$  counter stages, which are fully synchronous with each other.

With an input frequency of 1 MHz, the MMP 5009 provides the basic time periods necessary for most frequency measuring instruments, i.e., 1  $\mu$ s through 100 seconds. One-minute, ten-minute, and one-hour periods are also available using a 1 MHz input. Using a 1/1.2 MHz input, the MMP 5009 can also provide a 50/60 Hz output for accurate generation of line frequencies in portable instruments or clocks.

The time-base output (TIME OUT) is a square wave; its frequency is determined by the selected counter division, and by the oscillator or external input frequency. The falling edge of the output square wave should be used to control external gating circuitry..

## FEATURES

- Ion-implanted for full TTL/DTL compatibility
- Internal clock operates from:
  - External signal
  - External RC network
  - External crystal
- Operates dc to above 1 MHz
- Binary-encoded for frequency selection
- Resettable to highest or lowest state
- Twenty different modes of division

## APPLICATIONS

- Frequency measuring instruments, timers, clocks.

## ABSOLUTE MAXIMUM RATINGS

|  |       |    |        |
|--|-------|----|--------|
| Voltage On Any Terminal Relative to $V_{SS}$ | +0.3  | to | -20 V  |
| Operating Temperature Range (Ambient)        | 0°C   | to | +70°C  |
| Storage Temperature Range (Ambient)          | -55°C | to | +150°C |

## PIN CONNECTIONS

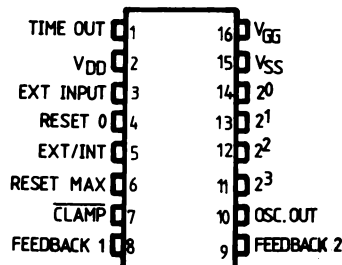

BLOCK DIAGRAM

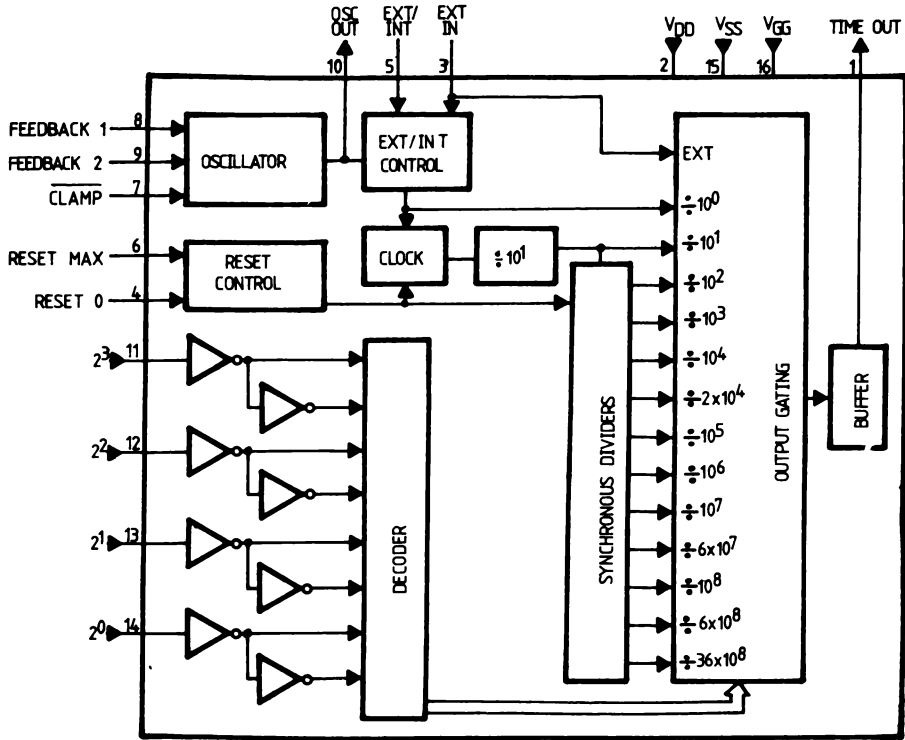

Fig. 1

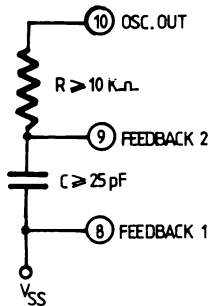
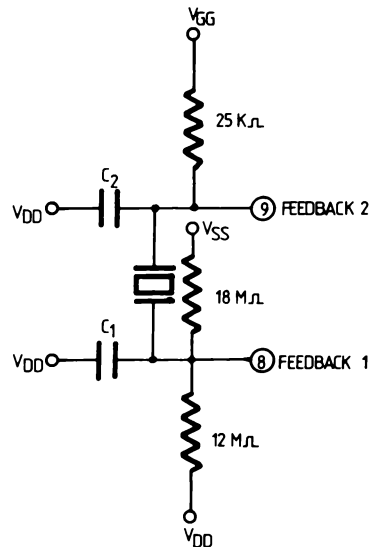

Fig. 2



## FUNCTIONAL DESCRIPTION

### TIME OUT, Pin 1

TIME OUT is the output of the divider chain. It is a square wave whose period depends upon the division mode. For this reason, external circuitry should be triggered on the falling edge of this signal.

### $V_{DD}$ , Pin 2

$V_{DD}$  is normally to ground for the chip and the other supply voltages are measured with respect to  $V_{DD}$ .

### EXT INPUT, Pin 3

When using an external frequency source to operate the MMP 5009, that signal should be applied at EXT IN and EXT/INT should be brought to a logic 1 level. The counters are incremented on the falling edge of EXT IN and the signal applied to this pin must be TTL-compatible. When unused, this pin can be tied either high or low.

### RESET O, Pin 4

A positive-going pulse of 10  $\mu$ s or longer applied to RESET O will reset the counters to their lowest state. Taking RESET O to the most negative voltage,  $V_{GG}$ , allows bypassing portions of the divider chain for testing or other purposes according to Table 1.

### EXT/INT, Pin 5

A logic 1 level on EXT/INT will gate the signal present at EXT/IN through to the counters. A logic 0 level applied to EXT/INT will gate the internal oscillator (RC/crystal) through to the counters.

### RESET MAX, Pin 6

A positive going pulse of 10  $\mu$ s or longer on RESET MAX will reset counters to their highest state. RESET MAX enables the user to set up the counters to provide a falling TIME OUT edge at the next oscillator cycle or negative going EXT IN, regardless of which divider chain is selected.

Taking RESET MAX to the most negative voltage,  $V_{GG}$ , allows bypassing portions of the divider chain for testing or for other purposes given in Table 1.

### CLAMP, Pin 7

CLAMP is used in conjunction with the RC mode of operation. Its purpose is to provide accurate start-up operations.

When CLAMP is taken to a logic 0 level, the internal circuitry is held at a fixed reference voltage. Then, when CLAMP is taken to a logic 1 level the oscillator's first cycle will be a full cycle.

### FEEDBACK 1 AND FEEDBACK 2, Pins 8 and 9

FEEDBACK 1 and FEEDBACK 2 are oscillator ports. Operation in the RC mode is achieved as shown in Figure 1. Frequency is approximately  $0.8/RC$ . R must be greater than or equal to 10 k $\Omega$  and C must be greater than or equal to 25 pF for proper operation. Operation in the crystal oscillator mode is shown in Figure 2. The crystal operates in the parallel resonant mode, should operate properly with a 5 mW drive, and should have a loading capacitance ( $C_L$ ) of 32 pF. Values for the resistors are chosen to bias the internal circuitry for optimum performance. The two capacitors are chosen to provide the loading capacitance ( $C_L$ ) specified for the selected crystal. The series combination of C1 and C2 should not exceed the value of  $C_L$ .

### OSC OUT, Pin 10

The oscillator output, provided at Pin 10, is not a true logic output but may be used to drive a high impedance device such as other MOS circuitry. OSC OUT reflects the state of the internal oscillator.

### $2^3, 2^2, 2^1, 2^0$ , Pins 11 through 14

The division selector inputs are used to select the ratio of the TIME OUT frequency to the oscillator input frequency. The effect of specific combinations of logic levels on these pins is shown in Table 1. Note that when all division selector inputs are high, the signal applied to EXT IN appears at the TIME OUT output. Also when RESET O and RESET MAX are used in conjunction with the division selector inputs, several more modes can be accessed. (See Table 1)

### $V_{SS}$ , Pin 15

$V_{SS}$  is the positive supply voltage and should be maintained at 5 Vdc  $\pm$  10% with respect to  $V_{DD}$ .



**V<sub>GG</sub>, Pin 16**

V<sub>GG</sub> is the negative supply voltage and should be maintained at -12 Vdc with respect to V<sub>DD</sub>.

**DIVISION MODES VS. CONTROL INPUTS**

Table 1

| DIVISION SELECTORS* |                |                |                | NORMAL<br>Mode 0<br>R <sub>MAX</sub> = 0<br>R <sub>0</sub> = 0 | BYPASS MODES   |  |  |
|---------------------|----------------|----------------|----------------|--|--|--|--|
| 2 <sup>3</sup>      | 2 <sup>2</sup> | 2 <sup>1</sup> | 2 <sup>0</sup> |  | Mode 1<br>R <sub>MAX</sub> = V <sub>GG</sub><br>R <sub>0</sub> = 0 | Mode 2<br>R <sub>MAX</sub> = 0<br>R <sub>0</sub> = V <sub>GG</sub> | Mode 3<br>R <sub>MAX</sub> = V <sub>GG</sub><br>R <sub>0</sub> = V <sub>GG</sub> |
| 0                   | 0              | 0              | 1              | ÷ 10 <sup>1</sup>  | ÷ 10 <sup>1</sup>  | ÷ 10 <sup>1</sup>  | ÷ 10 <sup>1</sup>  |
| 0                   | 0              | 1              | 0              | ÷ 10 <sup>2</sup>  | ÷ 10 <sup>2</sup>  | ÷ 10 <sup>2</sup>  | ÷ 10 <sup>2</sup>  |
| 0                   | 0              | 1              | 1              | ÷ 10 <sup>3</sup>  | ÷ 10 <sup>3</sup>  | ÷ 10 <sup>3</sup>  | ÷ 10 <sup>3</sup>  |
| 0                   | 1              | 0              | 0              | ÷ 10 <sup>4</sup>  | ÷ 10 <sup>4</sup>  | ÷ 10 <sup>4</sup>  | ÷ 10 <sup>4</sup>  |
| 0                   | 1              | 0              | 1              | ÷ 10 <sup>5</sup>  | ÷ 10 <sup>2</sup>  | ÷ 10 <sup>5</sup>  | ÷ 10 <sup>2</sup>  |
| 0                   | 1              | 1              | 0              | ÷ 10 <sup>6</sup>  | ÷ 10 <sup>3</sup>  | ÷ 10 <sup>6</sup>  | ÷ 10 <sup>3</sup>  |
| 0                   | 1              | 1              | 1              | ÷ 10 <sup>7</sup>  | ÷ 10 <sup>4</sup>  | ÷ 10 <sup>7</sup>  | ÷ 10 <sup>4</sup>  |
| 1                   | 0              | 0              | 0              | ÷ 10 <sup>8</sup>  | ÷ 10 <sup>5</sup>  | ÷ 10 <sup>5</sup>  | ÷ 10 <sup>2</sup>  |
| 1                   | 0              | 0              | 1              | ÷ 6 x 10 <sup>7</sup>  | ÷ 6 x 10 <sup>4</sup>  | ÷ 6 x 10 <sup>4</sup>  | ÷ 6 x 10 <sup>1</sup>  |
| 1                   | 0              | 1              | 0              | ÷ 36 x 10 <sup>8</sup>   | ÷ 36 x 10 <sup>5</sup>   | ÷ 36 x 10 <sup>5</sup>   | ÷ 36 x 10 <sup>2</sup>   |
| 1                   | 0              | 1              | 1              | ÷ 6 x 10 <sup>8</sup>  | ÷ 6 x 10 <sup>5</sup>  | ÷ 6 x 10 <sup>5</sup>  | ÷ 6 x 10 <sup>2</sup>  |
| 1                   | 1              | 1              | 0              | ÷ 2 x 10 <sup>4</sup>  | ÷ 2 x 10 <sup>1</sup>  | ÷ 2 x 10 <sup>1</sup>  | ÷ 2 x 10 <sup>1</sup>  |

## \* SPECIAL ADDRESSES

0000 — Oscillator signal selected by EXT/INT appears at TIME OUT

1100 or 1101 — Forces TIME OUT to logic 0 level

1111 — Signal at EXT IN appears at TIME OUT

Logic 1 = High = V<sub>SS</sub>

Logic 0 = Low = V<sub>DD</sub>

**DC ELECTRICAL CHARACTERISTICS**

(V<sub>SS</sub> = + 5 V ± 10%; V<sub>DD</sub> = 0 V; V<sub>GG</sub> = -12.0 V ± 20%; 0°C ≤ T<sub>A</sub> ≤ 70° C)

|                 | PARAMETER                                     | VALUES               |                 |                       | UNITS | NOTES                            |
|-----------------|---|----------------------|-----------------|-----------------------|-------|----------------------------------|
|                 |   | min.                 | typ.●           | max.                  |       |                                  |
| V <sub>SS</sub> | Supply Voltage                                | +4,5                 |                 | +5,5                  | V     |                                  |
| V <sub>DD</sub> | Supply Voltage                                | 0,0                  |                 | 0,0                   | V     |                                  |
| V <sub>GG</sub> | Supply Voltage                                | -14,4                |                 | -9.6                  | V     |                                  |
| I <sub>SS</sub> | Supply Current, V <sub>SS</sub>               |                      | 6,0             | 11,0                  | mA    | Note 1                           |
| I <sub>GG</sub> | Supply Current, V <sub>GG</sub>               |                      | 6,0             | 11,0                  | mA    |                                  |
| R               | Feedback Resistance                           | 0,01                 |                 | 2,5                   | M     |                                  |
| V <sub>IL</sub> | Input Voltage, Logic 0,<br>Reset Inputs       | 0,0                  |                 | 0,8                   | V     | Note 2                           |
|                 | Reset (Bypass Mode)                           | V <sub>GG</sub>      |                 | V <sub>GG</sub> + 1,0 | V     |                                  |
|                 | All Other Logic Inputs                        |                      |                 | 0,8                   | V     |                                  |
| V <sub>IH</sub> | Input Voltage, Logic 1, All Lo-<br>gic Inputs | V <sub>SS</sub> -1,0 | V <sub>SS</sub> | V <sub>SS</sub> +0,3  | V     |                                  |
| I <sub>IL</sub> | Input Current, Logic 0                        |                      |                 | -1,6                  | mA    | Note 2<br>V <sub>I</sub> = 0,4 V |
| V <sub>OL</sub> | Output Voltage, Logic 0                       |                      |                 | 0,4                   | V     | I <sub>OL</sub> = 1,6 mA         |
| V <sub>OH</sub> | Output Voltage, Logic 1                       | 2,4                  |                 |                       | V     | I <sub>OH</sub> = 40 μA*         |

**AC CHARACTERISTICS**
 $V_{SS} = +5\text{ V} \pm 10\%$ ;  $V_{DD} = 0\text{V}$ ;  $V_{GG} = -12.0\text{V} \pm 20\%$ ;  $0^\circ\text{C} \leq T_A \leq 70^\circ\text{C}$ 

| PARAMETER  |   | VALUES         |           |      | UNITS         | NOTES                                    |
|------------|---|----------------|-----------|------|---------------|--|
|            |   | min.           | typ.●     | max. |               |  |
| $f_{XTAL}$ | Crystal Frequency   | 0.1            |           | 2.0  | MHz           |  |
| $f_{RC}$   | RC Frequency  | dc             |           | 200  | kHz           |  |
| $f_{EXT}$  | External Frequency  | dc             |           | 2.0  | MHz           |  |
| $t_{PL}$   | Logic 0 Pulse Width. $\overline{\text{CLAMP}}$<br>EXT INPUT | 1/2fOSC<br>200 |           |      | ns            | Note 5                                   |
| $t_{PH}$   | Logic 1 Pulse Width. EXT INPUT                              | 200            |           |      | ns            |  |
|            | RESET MAX   | 10.0           |           |      | $\mu\text{s}$ |  |
|            | RESET 0   | 10.0           |           |      | $\mu\text{s}$ |  |
| $f_{STA}$  | Frequency Stability   |                |           |      |               |  |
|            | w/Volt Change, RC Mode                                      |                | $\pm 3.0$ |      | %/V           | Note 3                                   |
|            | w/Temp. Change, RC Mode<br>Crystal Mode                     |                | -0.2<br>— |      | %/°C          | Note 4                                   |
| $t_{ee}$   | Jitter, Edge-to-Edge Variation                              |                | <15       |      | ns            | Temp. &<br>Supply<br>Voltage<br>Constant |

**NOTES**

- Typical values at  $V_{SS} = +5\text{V}$ ,  $V_{DD} = 0\text{V}$ ,  $V_{GG} = -12\text{V}$ , and  $T_A = 25^\circ\text{C}$ .
- 1. Logic inputs at  $V_{SS}$ , output open-circuited. Each logic input (See Note 2) contributes an additional 1.6 mA (max) to  $I_{SS}$  when at logic 0 level.
- 2. Logic inputs are: RESET MAX; RESET 0; Address inputs; EXT INPUT ; EXT/INT; and  $\overline{\text{CLAMP}}$ .
- 3. Frequency variations due to power supply changes only.
- 4. Crystal mode stability is dependent upon crystal.
- 5. Minimum logic 0 time at  $\overline{\text{CLAMP}}$  input is 50% of oscillator period. ( $f_{OSC}$  = oscillator frequency)
- \*  $V_{OH}$ ,  $V_{OL}$  apply only to TIME OUT.

**PULSE GENERATOR**

An extremely versatile pulse generator requiring few components is easily built using the MMP 5009. Three MMP 5009 circuits are used, as shown in Figure 3, to provide the three essential pulse generator elements: (1) a frequency source to determine pulse repetition rate; (2) a variable time delay; and (3) a pulse width generation.

This circuit provides repetition rates from 0.1 Hz to 100 KHz with delay times and pulse widths from 10  $\mu\text{s}$  to 10 seconds. Range selection is obtained by selecting the appropriate dividers, so that only three RC circuits are required. This eliminates the requirement for a different RC combination for each decade, commonly found in commercial instruments. Decade selection is accomplished by a binary code at the inputs to each MMP 5009 which could be provided by a coded rotary or thumbwheel switch. The vernier control is a 500K potentiometer. A 100K potentiometer is used as a trimmer for initial calibration. External TTL control logic is used to capture the accurately controlled negative edges as they emerge from each MMP 5009. The Reset and Clamp Inputs allow synchronization and first-cycle accuracy from the time-base circuits.

Other features can be added to the basic circuitry shown in Figure 2. For example, the output amplitude can be made adjustable by using high voltage, open-collector TTL circuitry with potentiometer control for amplitude. An extra position can be used on the frequency selection switch for an external trigger source. This trigger source should be connected to the first control D-type latch instead of the output from the 5009 (1) The frequency range may even be extended to 1.0 MHz with time delays reduced to 1  $\mu\text{s}$ , although some loss in RC stability would occur since the recommended data sheet frequency has been exceeded.

Fig. 3

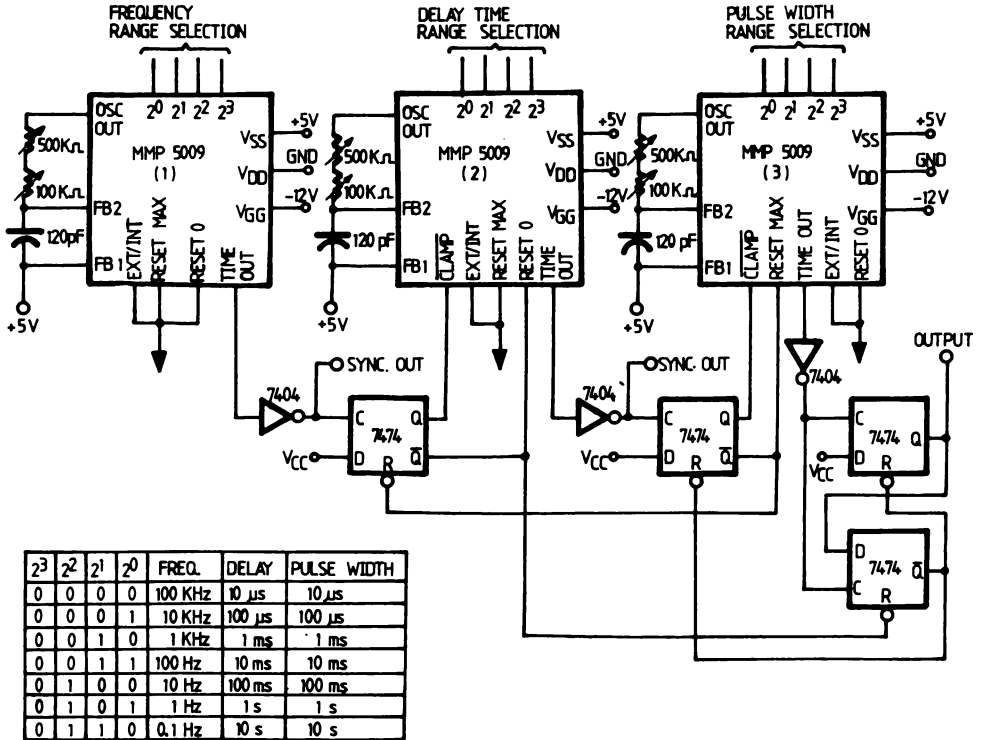

# STANDARD LIGHT EMITTING DIODES

## GENERAL DESCRIPTIONS

The Standard LEDs ( $\varnothing = 5 \text{ mm}$ ) are visible sources (red, amber, yellow or green) using a  $\text{GaAs}_{1-x}\text{P}_x$  ( $x = 0, .1$ ) They are made in planar process and epoxy encapsulated.

## FEATURES

- High Intensity
- Wide Viewing Angle
- IC Compatible
- Reliable and Rugged.

## APPLICATIONS

- Light Indicators
- Voltage Sensors

## ABSOLUTE MAXIMUM RATINGS

| PARAMETER   | VALUES    | UNIT               |
|---|-----------|--------------------|
| $I_{Fmax}$ DC Forward Current   | 50        | mA                 |
| $I_{Fpeak \text{ max}}$ Peak Forward Current (1 $\mu\text{sec}$ pulse width, 300 pps) | 1         | A                  |
| $P_{dmax}$ DC Power Dissipation   | 150       | mW                 |
| $T_A$ Operating Temperature   | 0...+70   | $^{\circ}\text{C}$ |
| $T_{stg}$ Storage Temperature   | -40...+85 | $^{\circ}\text{C}$ |
| $T_{ead}$ Lead Soldering Temperature  | +260      | $^{\circ}\text{C}$ |

## PACKAGE DIMENSIONS

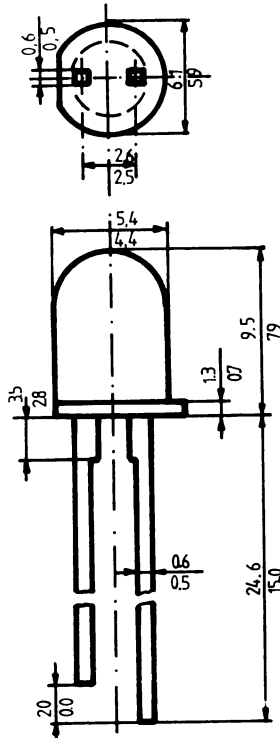

OPTOELECTRIC CHARACTERISTICS AT  $T_A = 25\text{ C}$ 

| PARAMETER                        | TEST CONDITIONS                          | DEVICE   | VALUES |      | UNIT |
|----------------------------------|--|--|--------|------|------|
|                                  |  |  | min.   | max. |      |
| $I_V$ Luminous Intensity         | $I_F = 20\text{ mA}$                     | MDE 1101R, MDE 1101V   | 0,1    | 1    | mcd  |
|                                  |  | MDE 1102R, MDE 1102V   | 1      | 2    | mcd  |
|                                  |  | MDE 1103R, MDE 1103V   | 2      |      | mcd  |
|                                  |  | MDE 1101P, MDE 1101G   | 0,3    | 1,5  | mcd  |
|                                  |  | MDE 1102P, MDE 1102G   | 1,5    | 2,5  | mcd  |
|                                  |  | MDE 1103P, MDE 1103G   | 2,5    |      | mcd  |
| $\lambda_p$ Peak Wavelength      | $I_F = 20\text{ mA}$                     | MDE 1101R, MDE 1102R,<br>MDE 1103R   | 645    | 680  | nm   |
|                                  |  | MDE 1101P, MDE 1102P,<br>MDE 1103P   | 625    | 640  | nm   |
|                                  |  | MDE 1101G, MDE 1102G,<br>MDE 1103G   | 573    | 590  | nm   |
|                                  |  | MDE 1101V, MDE 1102V,<br>MDE 1103V   | 554    | 570  | nm   |
| $\theta_{1/2}$ Viewing Angle     | $I_F = 20\text{ mA}$                     |  | 40     |      | grad |
| $V_F$ Forward Voltage            | $I_F = 20\text{ mA}$                     | MDE 1101R, MDE 1102R,<br>MDE 1103R   |        | 2    | V    |
|                                  |  | MDE 1101P, MDE 1102P,<br>MDE 1103P<br>MDE 1101G, MDE 1102G,<br>MDE 1103G<br>MDE 1101V, MDE 1102V,<br>MDE 1103V |        | 3    | V    |
| $BV_R$ Reverse Breakdown Voltage | $I_R = 100\text{ }\mu\text{A}$           |  | 3      |      | V    |
| $C_o$ Capacitance                | $V_F = 0\text{ V}$<br>$f = 1\text{ MHz}$ | MDE 1101R, MDE 1102R,<br>MDE 1103R   |        | 70   | V    |
|                                  |  | MDE 1101P, MDE 1102P,<br>MDE 1103P<br>MDE 1101G, MDE 1102G,<br>MDE 1103G<br>MDE 1101V, MDE 1102V,<br>MDE 1103V |        | 60   | pF   |

Note: R — red  
V — green  
G — yellow  
P — amber

FORWARD CURRENT VS FORWARD VOLTAGE

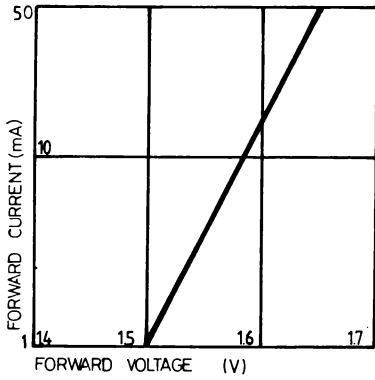

RELATIVE LUMINOUS INTENSITY VS

ANGULAR DISPLACEMENT

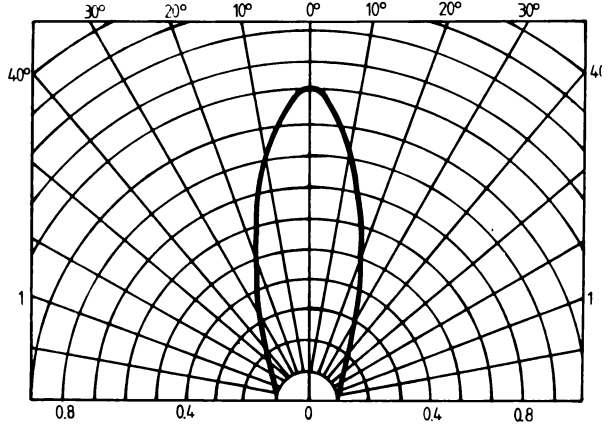

LUMINOUS INTENSITY VS. FORWARD CURRENT

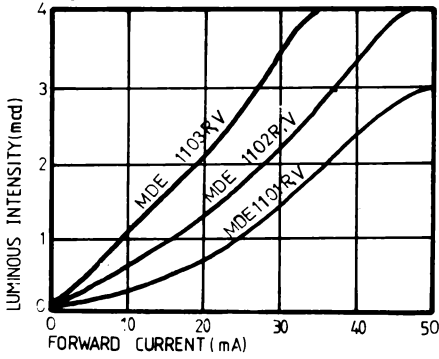

LUMINOUS INTENSITY VS FORWARD CURRENT

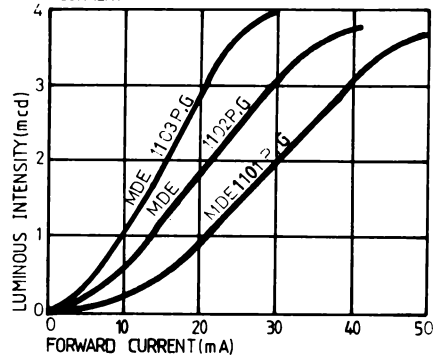

# RECTANGULAR LIGHT EMITTING DIODES

## GENERAL DESCRIPTION

The MDE 1531...3R (P, G or V) are visible sources (red, amber, yellow or green) using a planar technology GaAs<sub>1-x</sub>P<sub>x</sub> (x = 0...1). They utilise a tinted, diffused epoxy to provide high contrast and a flat high intensity emitting surface; borderless package design allows creation of uninterrupted light emitting areas.

## FEATURES

- High Luminous Intensity
- Rectangular Light Emitting surface
- Long Life
- IC Compatible
- Low Current Requirements

## APPLICATIONS

- Flush Mounted Panel Indicators
- Backlighting Legends
- Bar graph Display

## ABSOLUTE MAXIMUM RATINGS

| PARAMETER       | VALUES  | UNIT         |
|-----------------|---|--------------|
| $I_{Fmax}$      | DC Forward Current                                      | 50 mA        |
| $I_{Fpeak max}$ | Peak Forward Current (1 $\mu$ sec pulse width, 300 pps) | 1 A          |
| $P_{dmax}$      | DC Power Dissipation                                    | 150 mW       |
| $T_A$           | Operating Temperature                                   | 0...+70 °C   |
| $T_{stg}$       | Storage Temperature                                     | -40...+85 °C |
| $T_{lead}$      | Lead Soldering Temperature                              | +260 °C      |

## PACKAGE DIMENSIONS

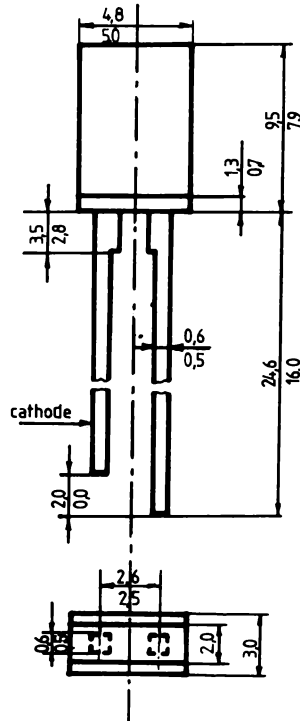

**OPTOELECTRONIC CHARACTERISTICS AT T<sub>A</sub> = 25°C**

| PARAMETER                                   | TEST CONDITIONS                 | DEVICE  | VALUES |      | UNIT |
|---|---------------------------------|---|--------|------|------|
|   |                                 |   | min.   | max. |      |
| I <sub>V</sub> Luminous Intensity           | I <sub>F</sub> = 20 mA          | MDE 1531R<br>MDE 1531V  | 0.1    | 1    | mcd  |
|   |                                 | MDE 1532R<br>MDE 1532V  | 1      | 2    | mcd  |
|   |                                 | MDE 1533R<br>MDE 1533V  | 2      |      | mcd  |
|   |                                 | MDE 1531P<br>MDE 1531G  | 0.3    | 1.5  | mcd  |
|   |                                 | MDE 1532P<br>MDE 1532G  | 1.5    | 2.5  | mcd  |
|   |                                 | MDE 1533P<br>MDE 1533G  | 2.5    |      | mcd  |
| λ <sub>p</sub> Peak Wavelength              | I <sub>F</sub> = 20 mA          | MDE 1531R<br>MDE 1532R<br>MDE 1533R   | 645    | 680  | nm   |
|   |                                 | MDE 1531P<br>MDE 1532P<br>MDE 1533P   | 625    | 640  | nm   |
|   |                                 | MDE 1531G<br>MDE 1532G<br>MDE 1533G   | 573    | 590  | nm   |
|   |                                 | MDE 1531V<br>MDE 1532V<br>MDE 1533V   | 554    | 570  | nm   |
| θ <sub>1-2</sub> Viewing Angle              | I <sub>F</sub> = 20 mA          |   |        | 40   | grad |
| V <sub>F</sub> Forward Voltage              | I <sub>F</sub> = 20 mA          | MDE 1531R<br>MDE 1532R<br>MDE 1533R   |        | 2    | V    |
|   |                                 | MDE 1531P<br>MDE 1532P<br>MDE 1533P<br>MDE 1531G<br>MDE 1532G<br>MDE 1533G<br>MDE 1531V<br>MDE 1532V<br>MDE 1533V |        | 3    | V    |
| BV <sub>R</sub> Reverse Breakdown Voltage I | I <sub>R</sub> = 100 μA         |   | 3      |      | V    |
| C <sub>0</sub> Capacitance                  | V <sub>F</sub> = 0 V, f = 1 MHz | MDE 1531R<br>MDE 1532R<br>MDE 1533R   |        | 70   | pF   |



**OPTOELECTRONIC CHARACTERISTICS AT  $T_A = 25^\circ\text{C}$**

| PARAMETER | TEST CONDITIONS | DEVICE  | VALUES |      | UNIT |
|-----------|-----------------|---|--------|------|------|
|           |                 |   | min.   | max. |      |
|           |                 | MDE 1531P<br>MDE 1532P<br>MDE 1533P<br>MDE 1531G<br>MDE 1532G<br>MDE 1533G<br>MDE 1531V<br>MDE 1532V<br>MDE 1533V |        | 60   | pF   |

Note: R — red  
V — green  
G — yellow  
P — amber

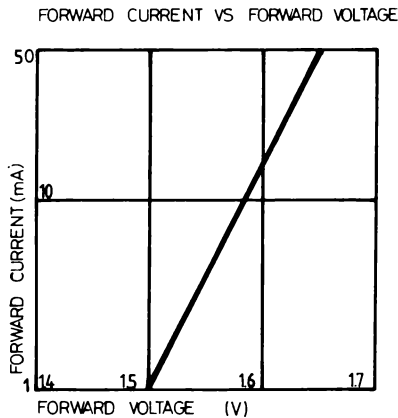
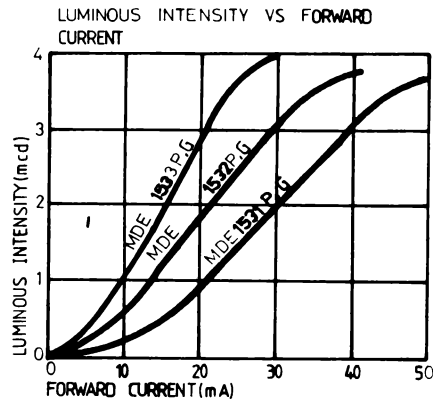
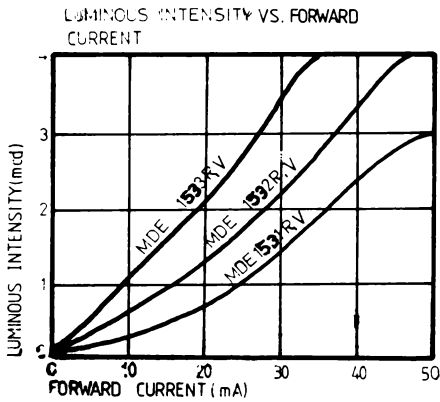

# TRIANGULAR LIGHT EMITTING DIODES

## GENERAL DESCRIPTION

The MDE 1541...3R (P, G or V) are visible sources (red, amber, yellow or green) using a planar technology GaAs<sub>x</sub>P<sub>1-x</sub> (x = 0...1). They utilise a tinted, diffused epoxy to provide high contrast and a flat high intensity emitting surface; borderless package design allows creation of uninterrupted light emitting areas.

## FEATURES

- High Intensity
- Rectangular Light Emitting surface
- Long Life
- IC Compatible
- Low Current Requirements

## APPLICATIONS

- Light Indicators

## ABSOLUTE MAXIMUM RATINGS

| PARAMETER              | VALUES   | UNIT         |
|------------------------|--|--------------|
| I <sub>Fmax</sub>      | DC Forward Current                                 | 50 mA        |
| I <sub>Fpeak max</sub> | Peak Forward Current (1 μsec pulse width, 300 pps) | 1 A          |
| P <sub>dmax</sub>      | DC Power Dissipation                               | 150 mW       |
| T <sub>A</sub>         | Operating Temperature                              | 0...+70 °C   |
| T <sub>stg</sub>       | Storage Temperature                                | -40...+85 °C |
| T <sub>ead</sub>       | Lead Soldering Temperature                         | +260 °C      |

## PACKAGE DIMENSIONS

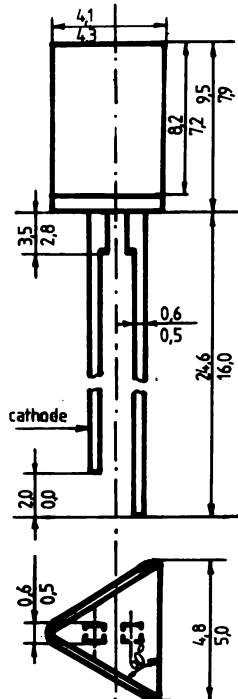

**OPTOELECTRONIC CHARACTERISTICS AT  $T_A = 25^\circ\text{C}$**

| PARAMETER                    | TEST CONDITIONS      | DEVICE  | VALUES |      | UNIT |
|------------------------------|----------------------|---|--------|------|------|
|                              |                      |   | min.   | max. |      |
| $I_V$ Luminous Intensity     | $I_F = 20\text{ mA}$ | MDE 1541R<br>MDE 1541V  | 0.1    | 1    | mcd  |
|                              |                      | MDE 1542R<br>MDE 1542V  | 1      | 2    | mcd  |
|                              |                      | MDE 1543R<br>MDE 1543V  | 2      |      | mcd  |
|                              |                      | MDE 1541P<br>MDE 1541G  | 0.3    | 1.5  | mcd  |
|                              |                      | MDE 1542P<br>MDE 1542G  | 1.5    | 2.5  | mcd  |
|                              |                      | MDE 1543P<br>MDE 1543G  | 2.5    |      | mcd  |
| $\lambda_D$ Peak Wavelength  | $I_F = 20\text{ mA}$ | MDE 1541R<br>MDE 1542R<br>MDE 1543R   | 645    | 680  | nm   |
|                              |                      | MDE 1541P<br>MDE 1542P<br>MDE 1543P   | 625    | 640  | nm   |
|                              |                      | MDE 1541G<br>MDE 1542G<br>MDE 1543G   | 573    | 590  | nm   |
|                              |                      | MDE 1541V<br>MDE 1542V<br>MDE 1543V   | 554    | 570  | nm   |
| $\theta_{1/2}$ Viewing Angle | $I_F = 20\text{ mA}$ |   |        | 40   | grad |
| $V_F$ Forward Voltage        | $I_F = 20\text{ mA}$ | MDE 1541R<br>MDE 1542R<br>MDE 1543R   |        | 2    | V    |
|                              |                      | MDE 1541P<br>MDE 1542P<br>MDE 1543P<br>MDE 1541G<br>MDE 1542G<br>MDE 1543G<br>MDE 1541V<br>MDE 1542V<br>MDE 1543V |        | 3    | V    |

**OPTOELECTRONIC CHARACTERISTICS AT  $T_A = 25^\circ\text{C}$**

| PARAMETER                        | TEST CONDITIONS                        | DEVICE  | VALUES |      | UNIT |
|----------------------------------|--|---|--------|------|------|
|                                  |  |   | min.   | max. |      |
| $BV_R$ Reverse Breakdown Voltage | $I_R = 100 \mu\text{A}$                |   | 3      |      | V    |
| $C_o$ Capacitance                | $V_F = 0 \text{ V}, f = 1 \text{ MHz}$ | MDE 1541R<br>MDE 1542R<br>MDE 1543R   |        | 70   | pF   |
|                                  |  | MDE 1541P<br>MDE 1542P<br>MDE 1543P<br>MDE 1541G<br>MDE 1542G<br>MDE 1543G<br>MDE 1541V<br>MDE 1542V<br>MDE 1543V |        | 60   | pF   |

Note: R — red  
V — green  
G — yellow  
P — amber

FORWARD CURRENT VS FORWARD VOLTAGE

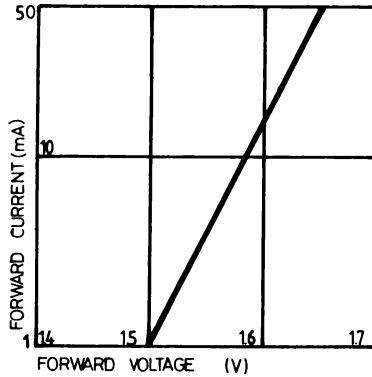

LUMINOUS INTENSITY VS. FORWARD CURRENT

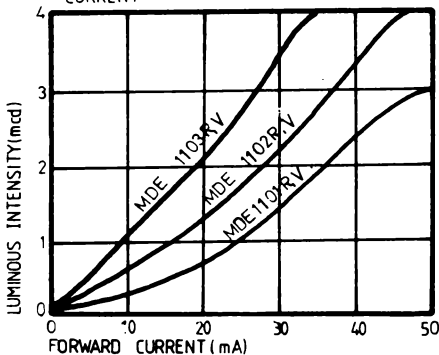

LUMINOUS INTENSITY VS FORWARD CURRENT

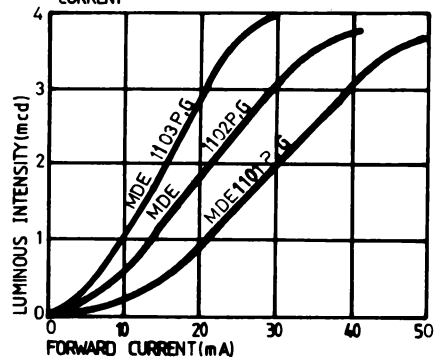

# RESISTOR LED S

## GENERAL DESCRIPTIONS

The resistor LED S (5 V/16 mA) are visible sources (red, amber, yellow or green) with epoxy lens. The LED are using GaAs<sub>1-x</sub>P<sub>x</sub> (x = 0...1) and resistive silicon chips.

## FEATURES

- TTL Compatible
- Integral Current Limiting Resistor
- Rugged and Reliable

## APPLICATIONS

- Use in TTL circuits

## ABSOLUTE MAXIMUM RATINGS

| PARAMETER         | VALUES                     | UNIT      |    |
|-------------------|----------------------------|-----------|----|
| V <sub>Fmax</sub> | DC Forward Voltage         | 7         | V  |
| V <sub>Rmax</sub> | Reverse Voltage            | 7         | V  |
| P <sub>dmax</sub> | DC Power Dissipation       | 180.      | mW |
| I <sub>Fmax</sub> | DC Forward Current         | 25.       | mA |
| T <sub>A</sub>    | Operating Temperature      | 0...+70   | °C |
| T <sub>stg</sub>  | Storage Temperature        | -40...+85 | °C |
| T <sub>sol</sub>  | Lead Soldering Temperature | +260      | °C |

## PACKAGE DIMENSIONS

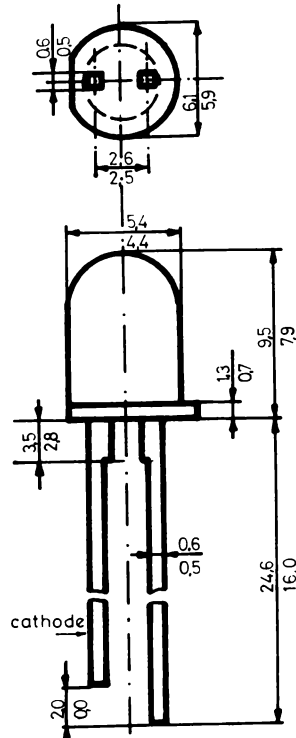
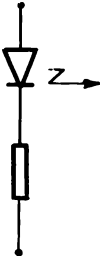

**OPTOELECTRIC CHARACTERISTICS AT  $T_A = 25^\circ\text{C}$**

| PARAMETER                        | TEST CONDITIONS                          | DEVICE   | min.                               | max.                     | UNIT                                   |
|----------------------------------|--|--|------------------------------------|--------------------------|--|
| $I_F$ Forward Current            | $V_F = 5\text{ V}$                       |  | 14                                 | 20                       | mA                                     |
| $I_V$ Luminous Intensity         | $V_F = 5\text{ V}$                       | MDE 1601R, MDE 1601V<br>MDE 1602R, MDE 1602V<br>MDE 1603R, MDE 1603V<br>MDE 1601P, MDE 1601G<br>MDE 1602P, MDE 1602G<br>MDE 1603P, MDE 1603G                           | 0.3<br>1<br>2<br>0.3<br>1.5<br>2.5 | 1<br>2                   | mcd<br>mcd<br>mcd<br>mcd<br>mcd<br>mcd |
| $\lambda_P$ Peak Wavelength      | $I_F = 16\text{ mA}$                     | MDE 1601P, MDE 1602P<br>MDE 1603P, MDE 1602G<br>MDE 1601G, MDE 1602G<br>MDE 1603G, MDE 1602V<br>MDE 1601V, MDE 1602V<br>MDE 1603V<br>MDE 1601R, MDE 1602R<br>MDE 1603R | 625<br>573<br>554<br>645           | 640<br>590<br>570<br>680 | nm<br>nm<br>nm<br>nm                   |
| $\theta_{1/2}$ Viewing Angle     | $I_F = 16\text{ mA}$                     |  | 40                                 |                          | grad                                   |
| $BV_R$ Reverse Breakdown Voltage | $I_R = 100\ \mu\text{A}$                 |  | 5                                  |                          | V                                      |
| $C_O$ Capacitance                | $V_F = 0\text{ V}$<br>$f = 1\text{ MHz}$ | MDE 1601R, MDE 1602R<br>MDE 1603R, MDE 1602P<br>MDE 1601P, MDE 1602P<br>MDE 1603P, MDE 1602G<br>MDE 1601G, MDE 1602G<br>MDE 1603G<br>MDE 1601V, MDE 1602V<br>MDE 1603V |                                    | 70<br>60                 | pF<br>pF                               |

Note: R — red  
V — green  
G — yellow  
P — amber

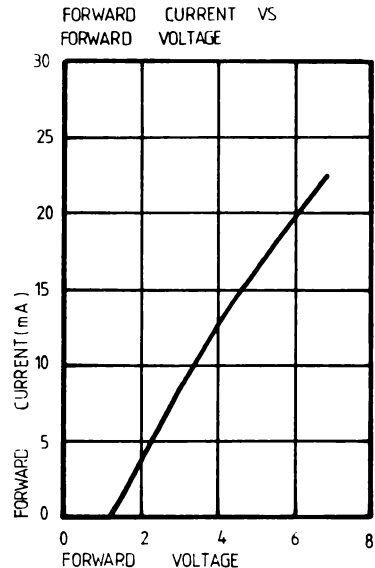
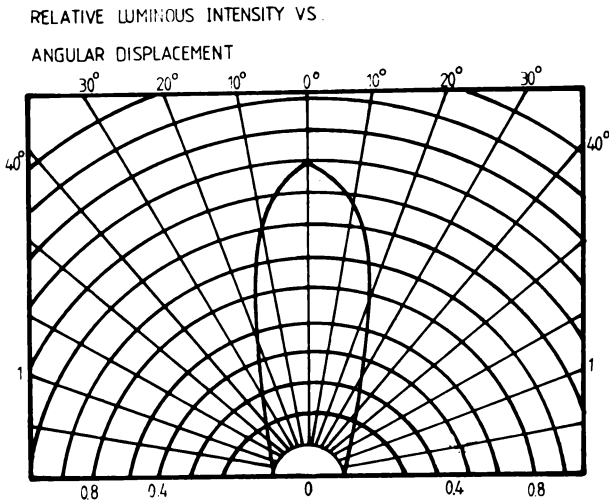

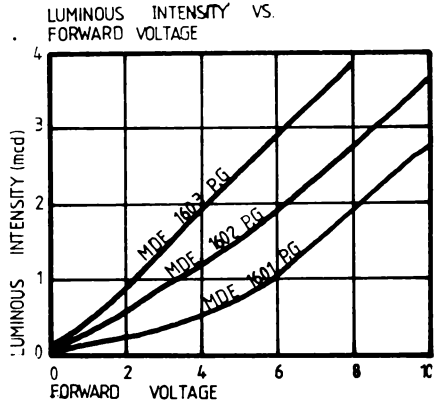
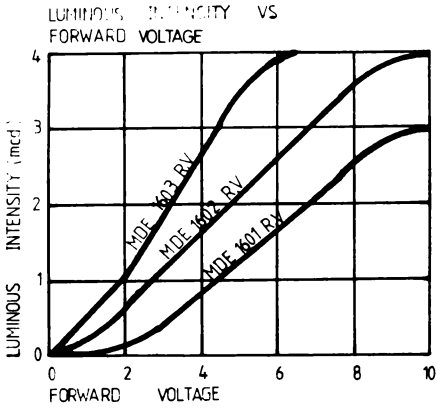

# 0.3 INCH RED OR GREEN SEVEN SEGMENT DISPLAY RIGHT HAND OR LEFT HAND DECIMAL POINT

## GENERAL DESCRIPTION

The 0.3 Inch (7.62 mm) Red or Green Seven segment Displays with Right Hand or Left Hand Decimal Point and common anode are plastic encapsulated. The emissive chips (LED) are made on GaP. These chips are mounted on dual in line pin-implanted PCB s.

## FEATURES

- High Luminous Intensity
- Low Power Requirements
- Wide Viewing Angle
- High Reliability and Long Life
- Easy Mounting on PCB or Sockets
- IC (TTL) Compatible

## APPLICATIONS

To display digital information used in electrical equipments where it is necessary.

## PACKAGE DIMENSIONS

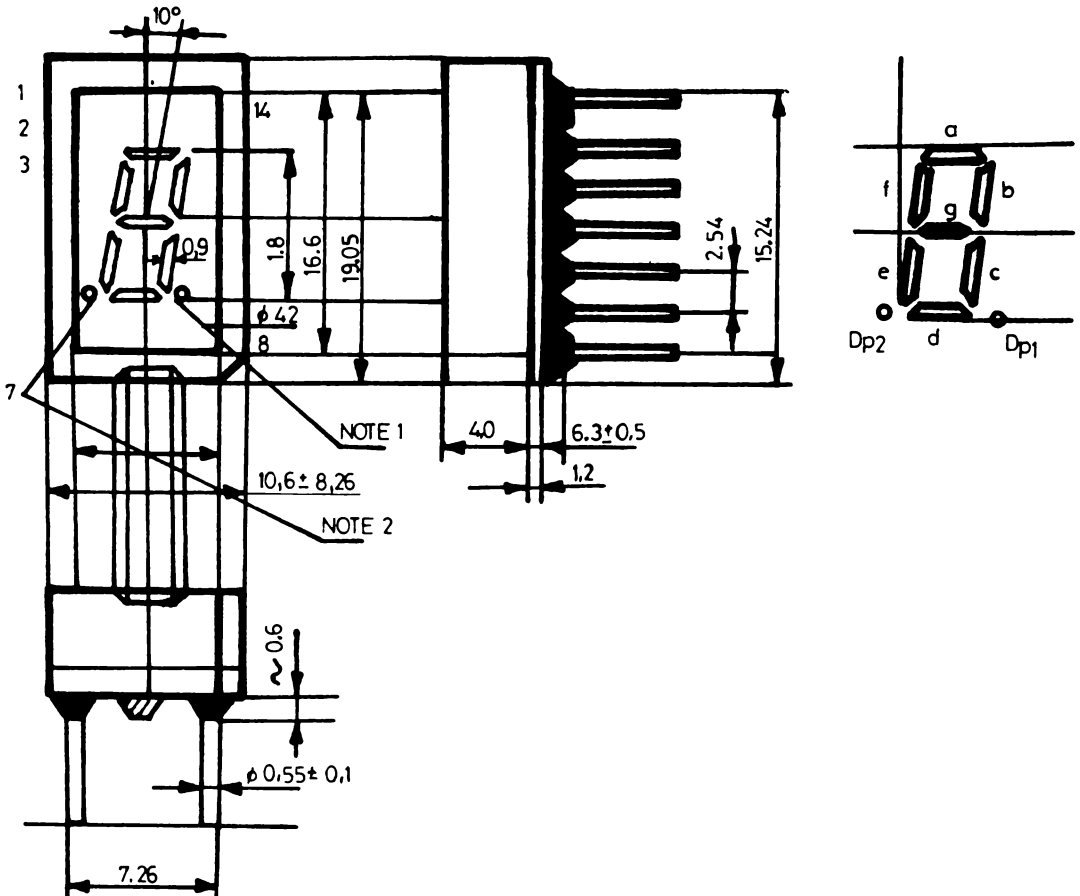



**ABSOLUTE MAXIMUM RATINGS**

| PARAMETER  | VALUES    | UNIT   |
|--|-----------|--------|
| I <sub>F</sub> DC Forward Current  | 20        | mA/seg |
| I <sub>FP</sub> Pulse (width = 1 msec, duty ratio = 25%) Forward Current | 60        | mA/seg |
| V <sub>R</sub> Reverse Voltage   | 3         | V      |
| P <sub>D</sub> Power Dissipation   | 300       | mW     |
| T <sub>A</sub> Operating Temperature                                     | -40...+85 | °C     |
| T <sub>stg</sub> Storage Temperature                                     | -40...+85 | °C     |

**OPTOELECTRONIC CHARACTERISTICS AT T<sub>A</sub> = 25°C**

| PARAMETER                                | TEST CONDITIONS                 | DEVICE   | VALUES |      | UNIT    |
|--|---------------------------------|--|--------|------|---------|
|  |                                 |  | Min.   | Max. |         |
| V <sub>F</sub> Forward Voltage           | I <sub>F</sub> = 10 mA/seg      |  |        | 3    | V       |
| V <sub>R</sub> Reverse Breakdown Voltage | I <sub>R</sub> = 100 μA/seg     |  | 3      |      | V/seg   |
| I <sub>V</sub> Luminous Intensity        | I <sub>F</sub> = 10 mA/seg      | MDE 2101R<br>MDE 2103R<br>MDE 2101V<br>MDE 2103V | 180    |      | μcd/seg |
|  |                                 | MDE 2102R<br>MDE 2104R<br>MDE 2102V<br>MDE 2104V | 300    |      | μcd/seg |
| λ <sub>p</sub> Emission Peak Wavelength  | I <sub>F</sub> = 10 mA/seg      | MDE 2101R<br>MDE 2102R<br>MDE 2103R<br>MDE 2104R | 645    | 725  | nm      |
|  |                                 | MDE 2101V<br>MDE 2102V<br>MDE 2103V<br>MDE 2104V | 554    | 570  | nm      |
| Δλ Line Half Width                       | I <sub>F</sub> = 10 mA/seg      |  |        | 100  | nm      |
| C <sub>o</sub> Capacitance               | V <sub>F</sub> = 0 V, f = 1 MHz |  |        | 200  | pF      |
| t Response Time                          |                                 |  | 500    |      | nsec    |

**CONNECTION DIAGRAM**

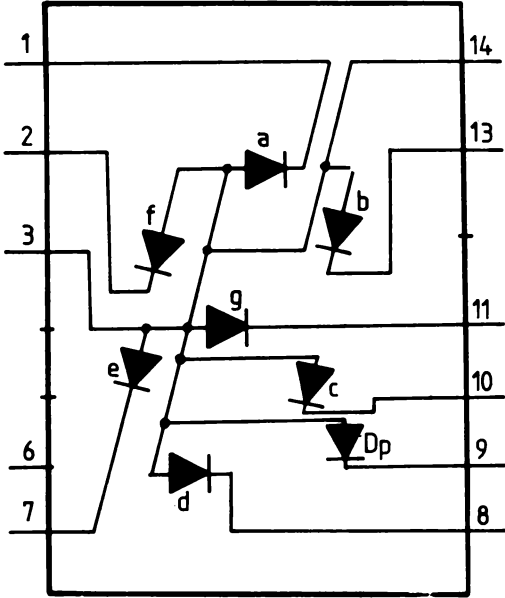

| PIN. NO. | ADDRESS      | PIN. NO. | ADDRESS      |
|----------|--------------|----------|--------------|
| 1.       | a CATHODE    | 8.       | d CATHODE    |
| 2.       | f CATHODE    | 9.       | D,p CATHODE  |
| 3.       | COMMON ANODE | 10.      | c CATHODE    |
| 4.       | NO PIN       | 11.      | g CATHODE    |
| 5.       | NO PIN       | 12.      | NO PIN       |
| 6.       | NO PIN       | 13.      | b CATHODE    |
| 7.       | e CATHODE    | 14.      | COMMON ANODE |

LUMINOUS INTENSITY VS. FORWARD CURRENT

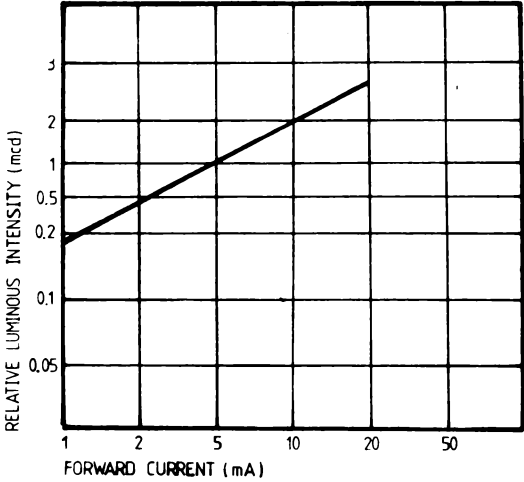

FORWARD CURRENT FORWARD VOLTAGE VS.

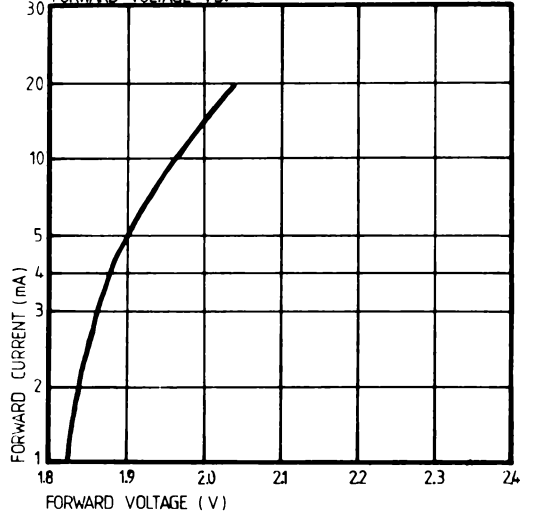

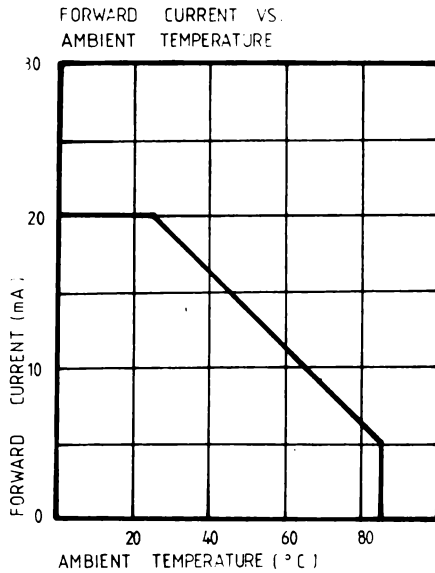
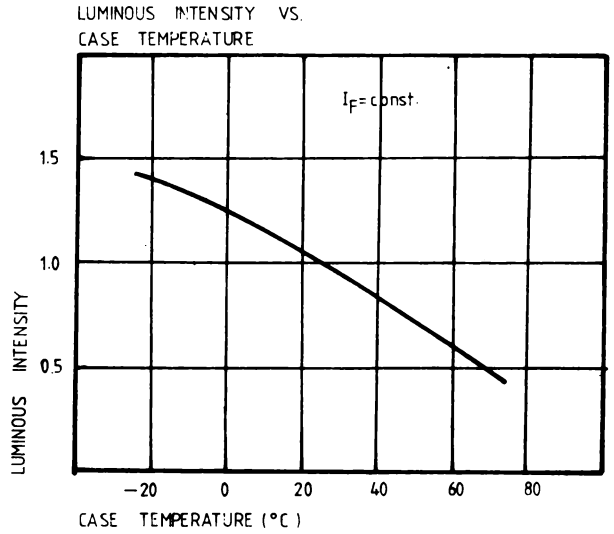
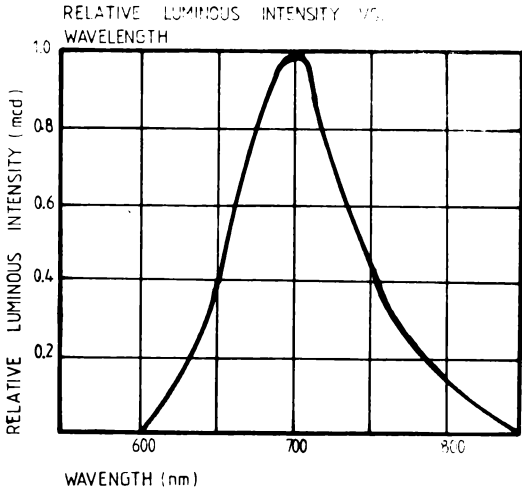

# 0.3 INCH RED OR GREEN SEVEN SEGMENT DISPLAY RIGHT HAND OR LEFT HAND DECIMAL POINT

## GENERAL DESCRIPTION

The 0.3 Inch (7.62 mm) Red or Green Seven segment Displays with Right Hand or Left Hand Decimal Point and common cathode are plastic encapsulated. The emissive chips (LED) are made on GaP. These chips are mounted on dual in line pin-implanted PCB s.

## FEATURES

- High Luminous Intensity
- Low Power Requirements
- Wide Viewing Angle
- High Reliability and Long Life
- Easy Mounting on PCB or Sockets
- IC (TTL) Compatible

## APPLICATIONS

To display digital information used in electrical equipments where it is necessary.

## PACKAGE DIMENSIONS

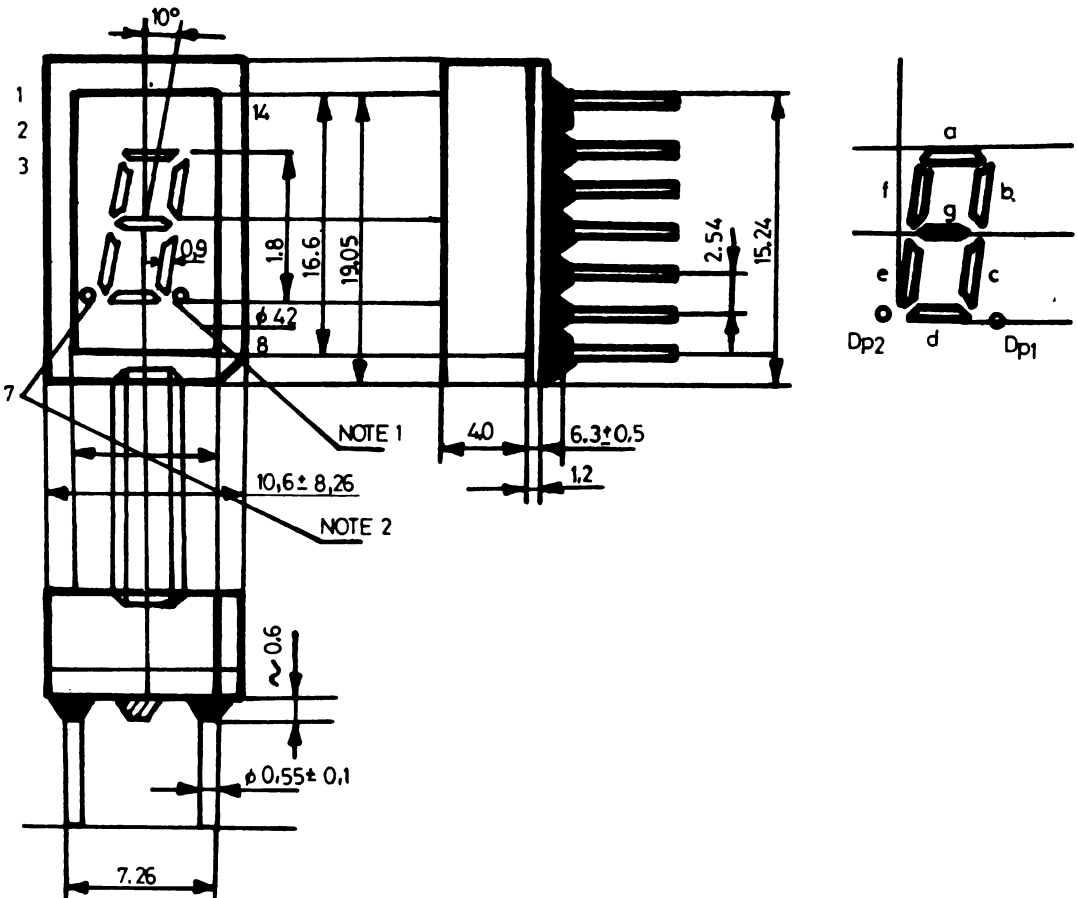

**ABSOLUTE MAXIMUM RATINGS**

| PARAMETER   | VALUES    | UNIT   |
|---|-----------|--------|
| $I_F$ DC Forward Current  | 20        | mA/seg |
| $I_{FP}$ Pulse (width = 1 msec, duty ratio = 25%) Forward Current | 60        | mA/seg |
| $V_R$ Reverse Voltage   | 3         | V      |
| $P_D$ Power Dissipation   | 300       | mW     |
| $T_A$ Operating Temperature                                       | -40...+85 | °C     |
| $T_{stg}$ Storage Temperature                                     | -40...+85 | °C     |

**OPTOELECTRIC CHARACTERISTICS AT  $T_A = 25^\circ\text{C}$**

| PARAMETER                            | TEST CONDITIONS                          | DEVICE   | VALUES |      | UNIT               |
|--------------------------------------|--|--|--------|------|--------------------|
|                                      |  |  | Min.   | Max. |                    |
| $V_F$ Forward Voltage                | $I_F = 10 \text{ mA/seg}$                |  |        | 3    | V                  |
| $V_R$ Reverse Breakdown Voltage      | $I_R = 100 \mu\text{A/seg}$              |  | 3      |      | V/seg              |
| $I_V$ Luminous Intensity             | $I_F = 10 \text{ mA/seg}$                | MDE 2111R<br>MDE 2113V<br>MDE 2111V<br>MDE 2113V | 180    |      | $\mu\text{cd/seg}$ |
|                                      |  | MDE 2112R<br>MDE 2114V<br>MDE 2112V<br>MDE 2114V | 300    |      | $\mu\text{cd/seg}$ |
| $\lambda_p$ Emission Peak Wavelength | $I_F = 10 \text{ mA/seg}$                | MDE 2111R<br>MDE 2112R<br>MDE 2113R<br>MDE 2114R | 645    | 725  | nm                 |
|                                      |  | MDE 2111V<br>MDE 2112V<br>MDE 2113V<br>MDE 2114V | 554    | 570  | nm                 |
| $\Delta\lambda$ Line Half Width      | $I_F = 10 \text{ mA/seg}$                |  |        | 100  | nm                 |
| $C_0$ Capacitance                    | $V_F = 0\text{V}$<br>$f = 1 \text{ MHz}$ |  |        | 200  | pF                 |
| $t$ Response Time                    |  |  | 500    |      | nsec               |

CONNECTION DIAGRAM

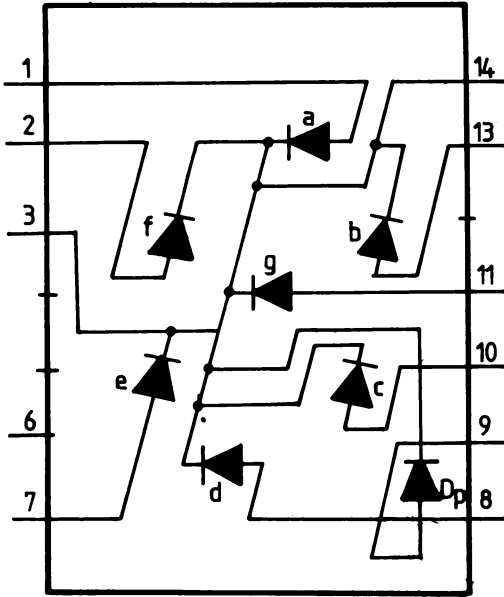

| PIN NO | ADDRESS        | PIN NO | ADDRESS        |
|--------|----------------|--------|----------------|
| 1      | a ANODE        | 8      | d ANODE        |
| 2      | f ANODE        | 9      | D.p ANODE      |
| 3      | COMMON CATHODE | 10     | c ANODE        |
| 4      | NO PIN         | 11     | g ANODE        |
| 5      | NO PIN         | 12     | NO PIN         |
| 6      | NO PIN         | 13     | b ANODE        |
| 7      | e ANODE        | 14     | COMMON CATHODE |

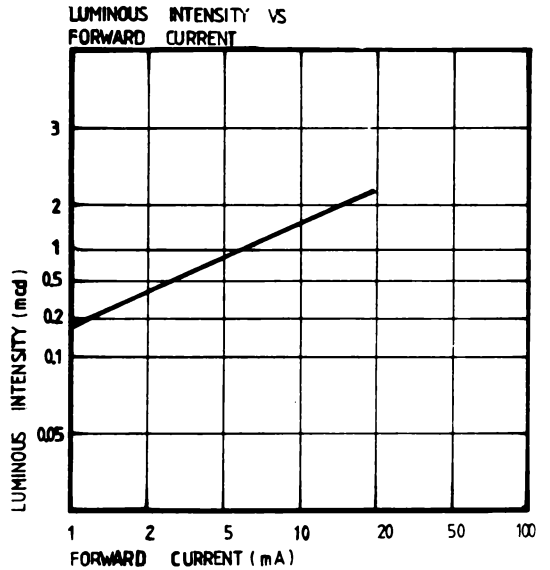
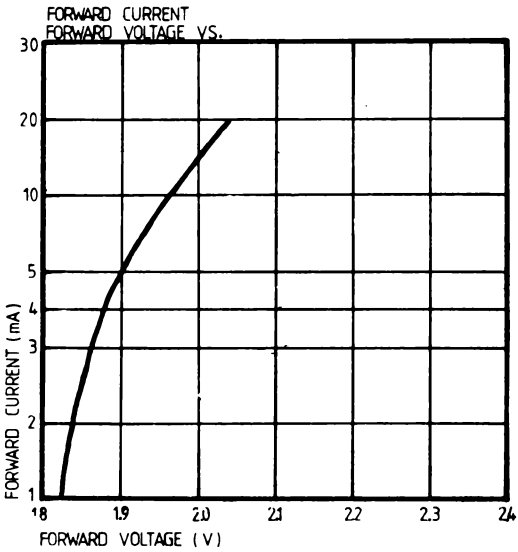

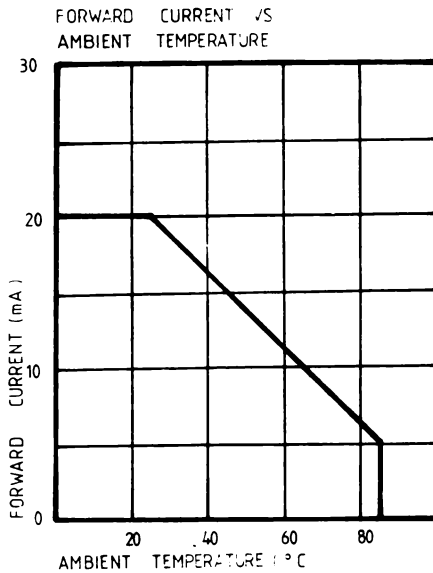
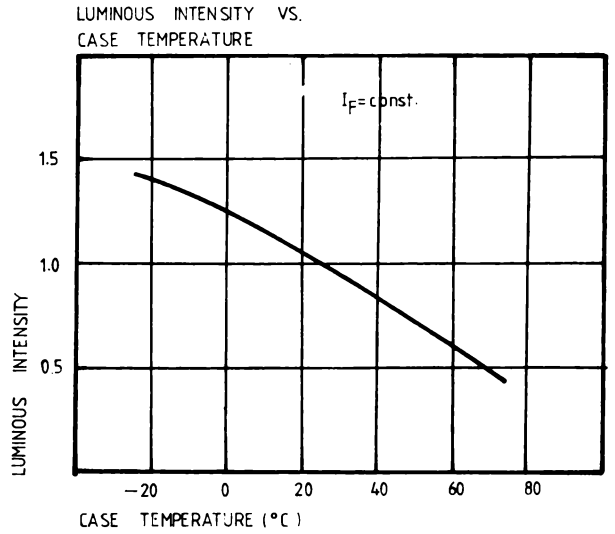
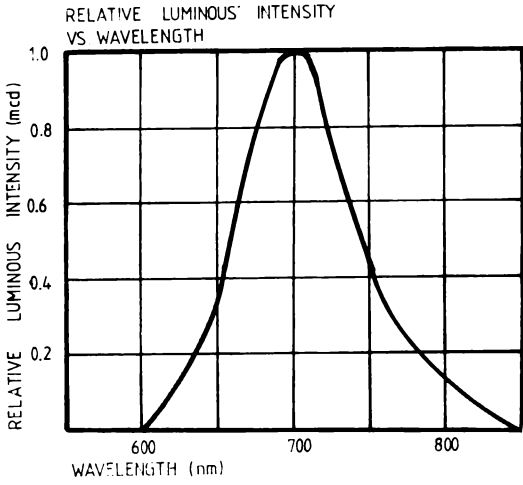

# 0.3 INCH RED OR GREEN OVERFLOW INDICATOR RIGHT HAND OR LEFT HAND DECIMAL POINT

## GENERAL DESCRIPTION

The 0.3 Inch (7.62 mm) Red or Green Overflow Indicators with Right Hand Decimal Point and common anode are plastic encapsulated. The emissive chips (LED) are made on GaP substrate. These chips are mounted on dual in line pinimplanted PCBs.

## FEATURES

- High Luminous Intensity
- Low Power Requirements
- Wide Viewing Angle
- High Reliability and Long Life
- Easy Mounting on PCB or Sockets
- IC (TTL) Compatible

## APPLICATIONS

To display digital information used in electrical equipments where it is necessary.

## PACKAGE DIMENSIONS

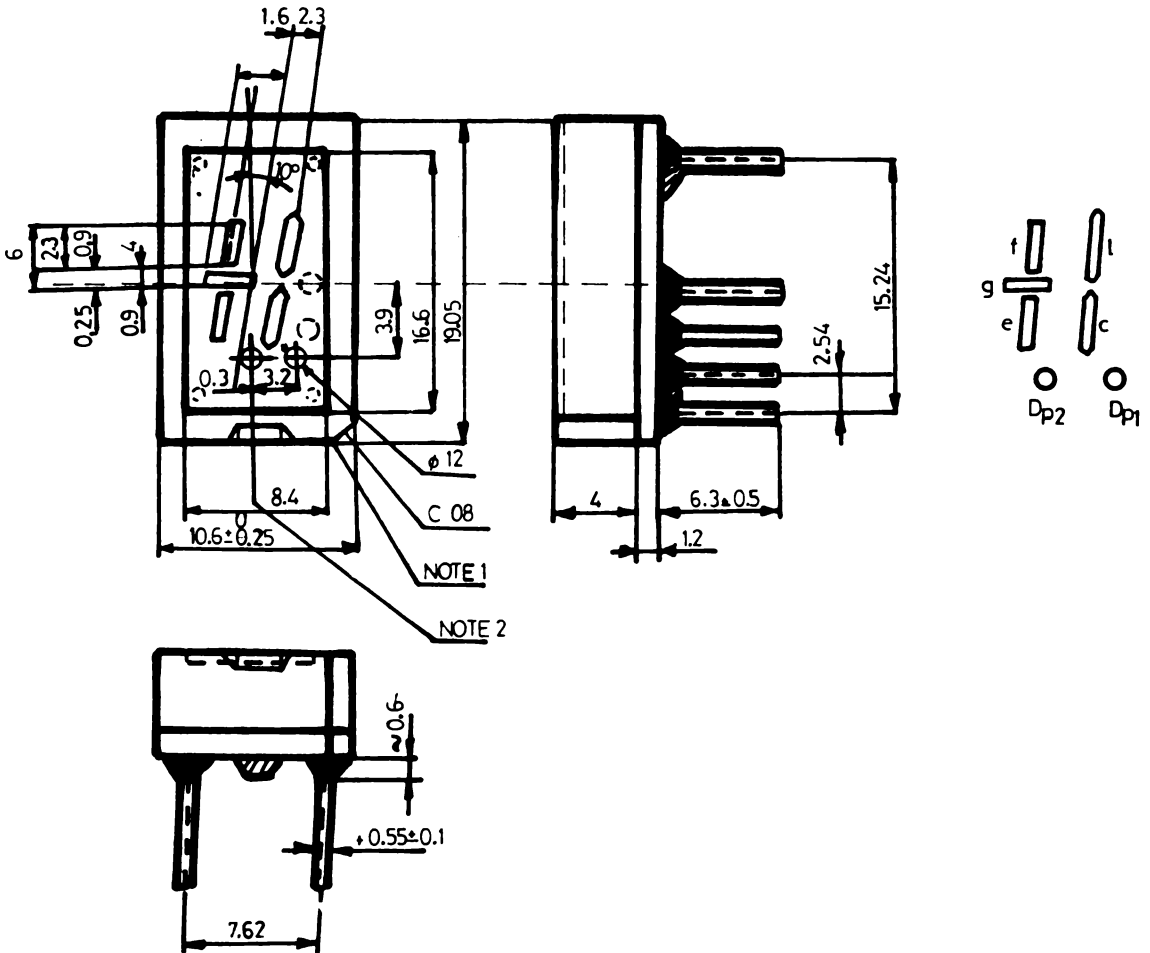



**ABSOLUTE MAXIMUM RATINGS**

| PARAMETER   | VALUES    | UNIT   |
|---|-----------|--------|
| I <sub>F</sub> DC Forward Current   | 20        | mA/seg |
| I <sub>FP</sub> Pulse (width = 1 msec, duty ratio = 25%)<br>Forward Current | 60        | mA/seg |
| V <sub>R</sub> Reverse Voltage  | 3         | V      |
| P <sub>D</sub> Power Dissipation  | 200       | mW     |
| T <sub>A</sub> Operating Temperature  | -40...+85 | °C     |
| T <sub>stg</sub> Storage Temperature  | -40...+85 | °C     |

**OPTOELECTRIC CHARACTERISTICS AT T<sub>A</sub> = 25°C**

| PARAMETER                                | TEST CONDITIONS                  | DEVICE   | VALUES |      | UNIT    |
|--|----------------------------------|--|--------|------|---------|
|  |                                  |  | Min.   | Max. |         |
| V <sub>F</sub> Forward Voltage           | I <sub>F</sub> = 10 mA/seg       |  |        | 3    | V       |
| V <sub>R</sub> Reverse Breakdown Voltage | I <sub>R</sub> = 100 μA/seg      |  | 3      |      | V/seg   |
| I <sub>V</sub> Luminous Intensity        | I <sub>F</sub> = 10 mA/seg       | MDE 2201R<br>MDE 2203V<br>MDE 2201V<br>MDE 2203V | 180    |      | μcd/seg |
|  |                                  | MDE 2202R<br>MDE 2204V<br>MDE 2202V<br>MDE 2204V | 300    |      | μcd/seg |
| λ <sub>p</sub> Emission Peak Wavelength  | I <sub>F</sub> = 10 mA/seg       | MDE 2201R<br>MDE 2202R<br>MDE 2203R<br>MDE 2204R | 645    | 725  | nm      |
|  |                                  | MDE 2201V<br>MDE 2202V<br>MDE 2203V<br>MDE 2204V | 554    | 570  | nm      |
| Δλ Line Half Width                       | I <sub>F</sub> = 10 mA/seg       |  |        | 100  | nm      |
| C <sub>0</sub> Capacitance               | V <sub>F</sub> = 0V<br>f = 1 MHz |  |        | 200  | pF      |
| t <sub>r</sub> Response Time             |                                  |  | 500    |      | nsec    |

CONNECTION DIAGRAM

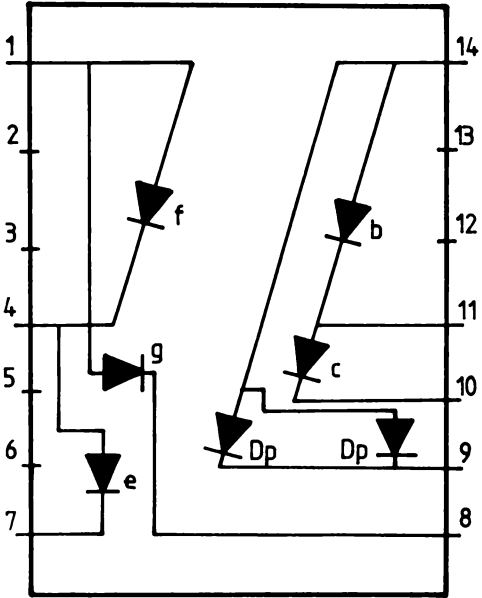

| PIN. NO. | ADDRESS            | PIN. NO. | ADDRESS          |
|----------|--------------------|----------|------------------|
| 1.       | f,g ANODE          | 8.       | g CATHODE        |
| 2.       | NO PIN             | 9.       | D,p CATHODE      |
| 3.       | NO PIN             | 10.      | c CATHODE        |
| 4.       | e ANODE, f CATHODE | 11.      | b CATODE c ANODE |
| 5.       | NO PIN             | 12.      | NO PIN           |
| 6.       | NO PIN             | 13.      | NO PIN           |
| 7.       | e CATHODE          | 14.      | b,D,p ANODE      |

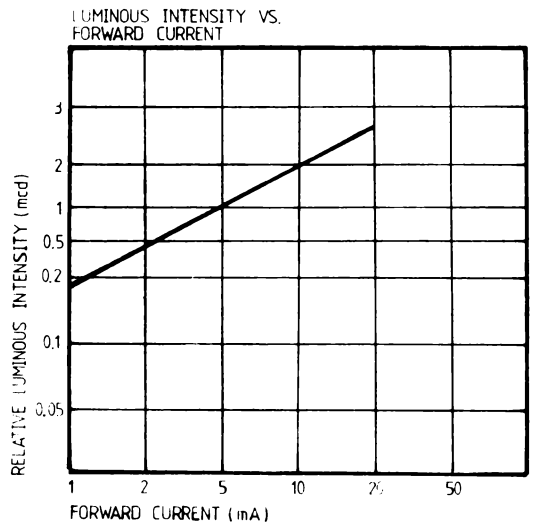
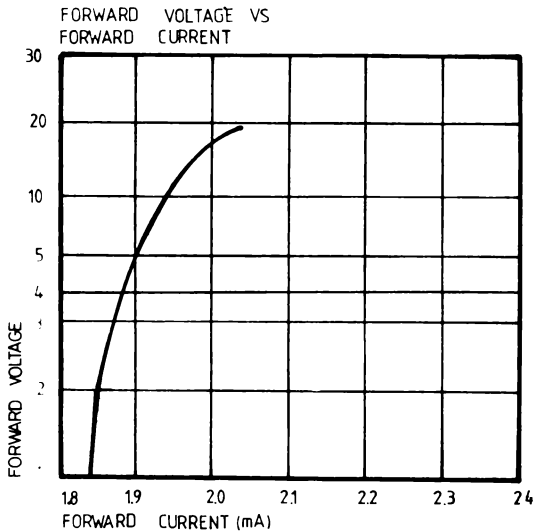

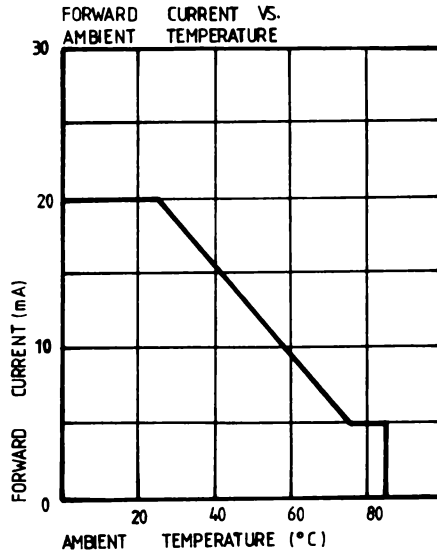
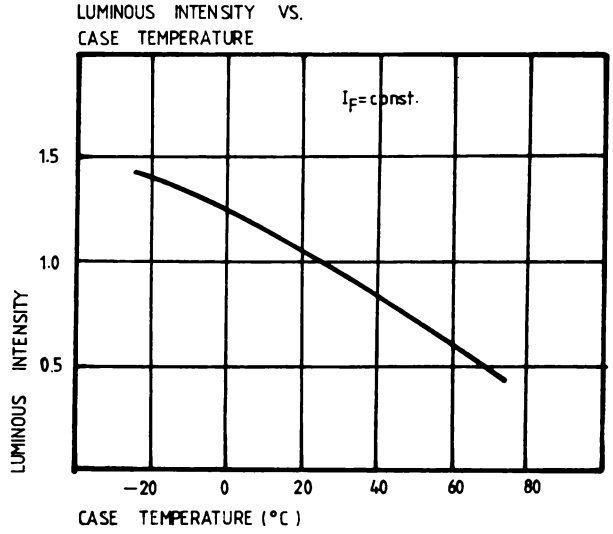
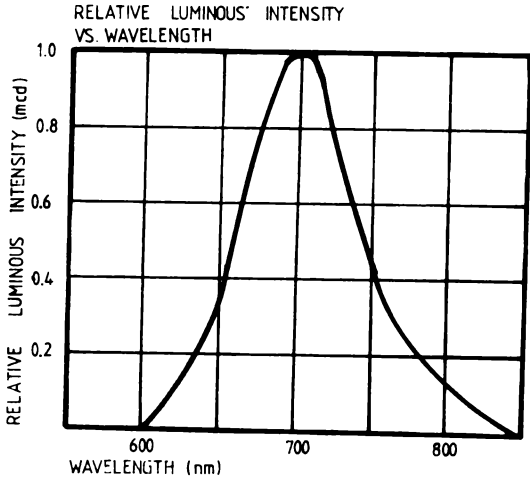

# 0.3 INCH RED OR GREEN OVERFLOW INDICATOR RIGHT HAND OR LEFT HAND DECIMAL POINT

## GENERAL DESCRIPTION

The 0.3 Inch (7.62 mm) Red or Green Overflow Indicators with Right Hand Decimal Point and common cathode are plastic encapsulated.

The emissive chips (LED) are made on GaP substrate. These chips are mounted on dual in line pin-planted PCB's.

## FEATURES

- High Luminous Intensity
- Low Power Requirements
- Wide Viewing Angle
- High Reliability and Long Life
- Easy Mounting on PCB or Sockets
- IC (TTL) Compatible

## APPLICATIONS

To display digital information used in electrical equipments where it is necessary.

## PACKAGE DIMENSIONS

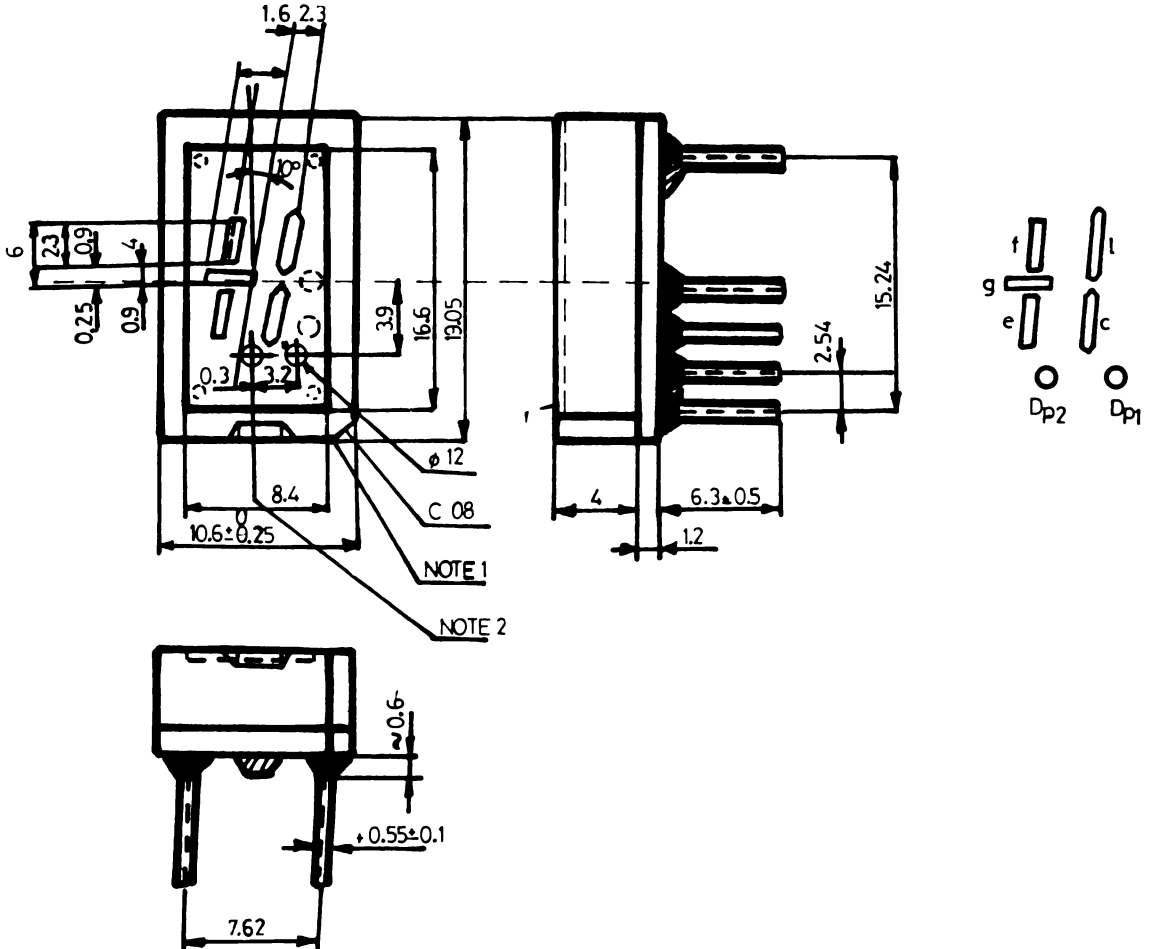

**ABSOLUTE MAXIMUM RATINGS**

| PARAMETER   | VALUES    | UNIT   |
|---|-----------|--------|
| I <sub>F</sub> DC Forward Current   | 20        | mA/seg |
| I <sub>FP</sub> Pulse (width = 1 msec, duty ratio = 25%)<br>Forward Current | 60        | mA/seg |
| V <sub>R</sub> Reverse Voltage  | 3         | V      |
| P <sub>D</sub> Power Dissipation  | 200       | mW     |
| T <sub>A</sub> Operating Temperature  | -40...+85 | °C     |
| T <sub>stg</sub> Storage Temperature  | -40...+85 | °C     |

**OPTOELECTRIC CHARACTERISTICS AT T<sub>A</sub> = 25°C**

| PARAMETER                                | TEST CONDITIONS                  | DEVICE   | VALUES |      | UNIT    |
|--|----------------------------------|--|--------|------|---------|
|  |                                  |  | Min.   | Max. |         |
| V <sub>F</sub> Forward Voltage           | I <sub>F</sub> = 10 mA/seg       |  |        | 3    | V       |
| V <sub>R</sub> Reverse Breakdown Voltage | I <sub>R</sub> = 100 μA/seg      |  | 3      |      | V/seg   |
| I <sub>V</sub> Luminous Intensity        | I <sub>F</sub> = 10 mA/seg       | MDE 2211R<br>MDE 2213V<br>MDE 2211V<br>MDE 2213V | 180    |      | μcd/seg |
|  |                                  | MDE 2212R<br>MDE 2214V<br>MDE 2212V<br>MDE 2214V | 300    |      | μcd/seg |
| λ <sub>p</sub> Emission Peak Wavelength  | I <sub>F</sub> = 10 mA/seg       | MDE 2211R<br>MDE 2212R<br>MDE 2213R<br>MDE 2214R | 645    | 725  | nm      |
|  |                                  | MDE 2211V<br>MDE 2212V<br>MDE 2213V<br>MDE 2214V | 554    | 570  | nm      |
| Δλ Line Half Width                       | I <sub>F</sub> = 10 mA/seg       |  |        | 100  | nm      |
| C <sub>0</sub> Capacitance               | V <sub>F</sub> = 0V<br>f = 1 MHz |  |        | 200  | pF      |
| t Response Time                          |                                  |  | 500    |      | nsec    |

FUNCTIONAL DIAGRAM

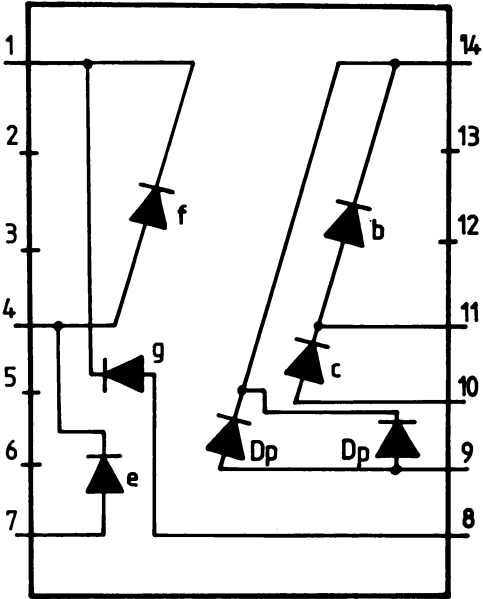

| PIN NO | ADDRESS              | PIN NO | ADDRESS              |
|--------|----------------------|--------|----------------------|
| 1      | f,g CATHODE          | 8      | g ANODE              |
| 2      | NO PIN               | 9      | D.p ANODE            |
| 3      | NO PIN               | 10     | c ANODE              |
| 4      | e CATHODE<br>f ANODE | 11     | b ANODE<br>c CATHODE |
| 5      | NO PIN               | 12     | NO PIN               |
| 6      | NO PIN               | 13     | NO PIN               |
| 7      | e ANODE              | 14     | b,D,p CATHODE        |

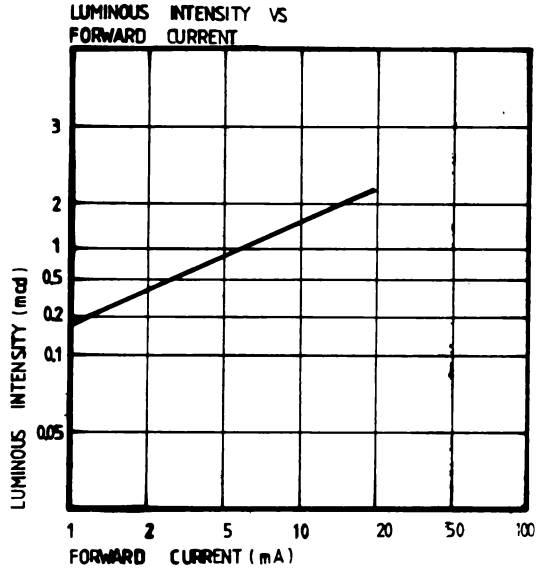
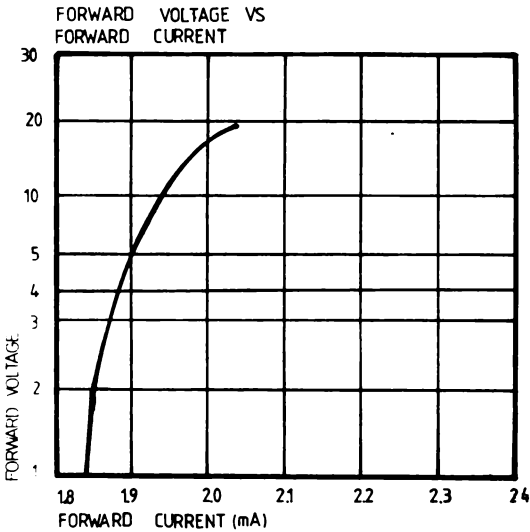

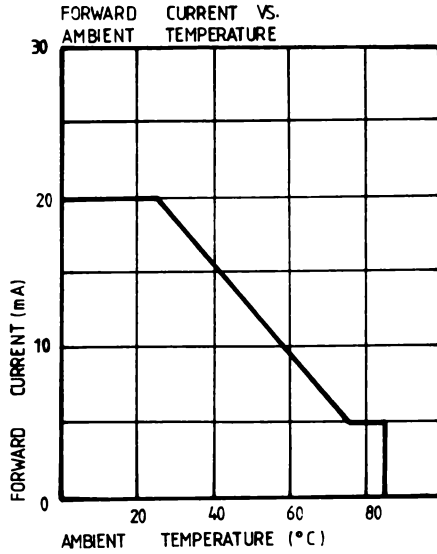
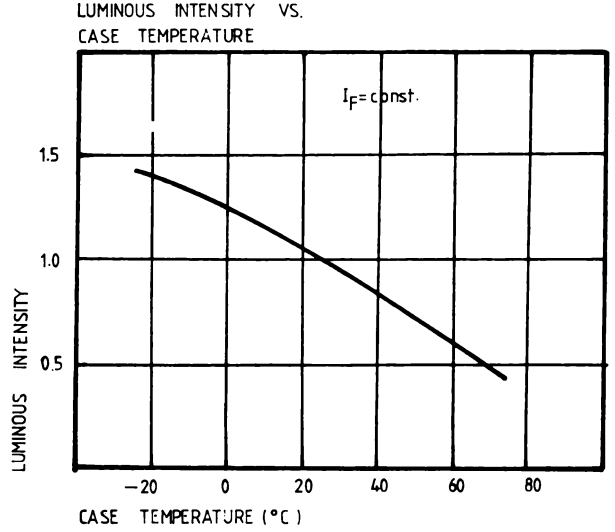
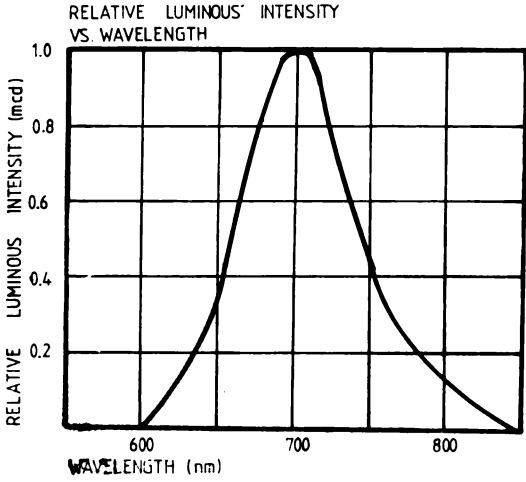

# 0.3. INCH 4 DIGITS RED OR GREEN LED NUMERIC DISPLAY

## GENERAL DESCRIPTION

The MDE 2573...4R and MDE 2573...4V are common anode seven segment GaP numeric displays. The large 7.62 (0.3 inch) high characters size generate a bright, continuously uniform seven segment display. They are made on printed circuit boards and plastic encapsulated.

## FEATURES

- High Luminous Intensity
- Wide Viewing Angle
- Uniform Alignment
- IC (TTL) Compatible
- Multiplexed addressable

## APPLICATIONS

To display digital information used in electrical equipments where it is necessary.

## ABSOLUTE MAXIMUM RATINGS

| PARAMETER   | VALUES    | UNIT   |
|---|-----------|--------|
| $I_F$ DC Forward Current  | 20        | mA/seg |
| $I_{FP}$ Pulse (width = 1 msec, duty ratio = 25%) Forward Current | 60        | mA/seg |
| $V_R$ Reverse Voltage   | 3         | V      |
| $P_D$ Power Dissipation   | 300       | mW     |
| $T_A$ Operating Temperature                                       | -40...+85 | °C     |
| $T_{stg}$ Storage Temperature                                     | -40...+85 | °C     |

## PACKAGE DIMENSIONS

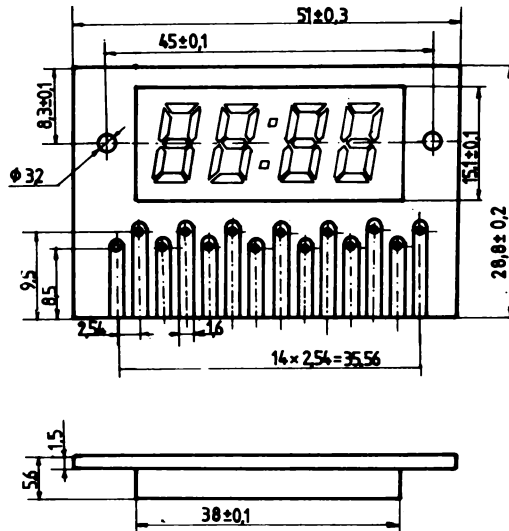



**OPTOELECTRONIC CHARACTERISTICS AT  $T_A = 25^\circ C$**

| PARAMETER                            | TEST CONDITIONS                      | DEVICE                 | VALUES |      | UNIT               |
|--------------------------------------|--------------------------------------|------------------------|--------|------|--------------------|
|                                      |                                      |                        | Min.   | Max. |                    |
| $V_F$ Forward Voltage                | $I_F = 10 \text{ mA/seg}$            |                        | 1.9    | 3    | V                  |
| $V_R$ Reverse Breakdown Voltage      | $I_R = 100 \text{ } \mu\text{A/seg}$ |                        | 3      |      | V/seg              |
| $I_V$ Luminous Intensity             | $I_F = 10 \text{ mA/seg}$            | MDE 2573R<br>MDE 2574V | 180    |      | $\mu\text{cd/seg}$ |
|                                      |                                      | MDE 2574R<br>MDE 2574V | 300    |      | $\mu\text{cd/seg}$ |
| $\lambda_p$ Emission Peak Wavelength | $I_F = 10 \text{ mA/seg}$            | MDE 2573R<br>MDE 2574R | 645    | 725  | nm                 |
|                                      |                                      | MDE 2573V<br>MDE 2574V | 554    | 570  | nm                 |
| $\Delta\lambda$ Line Half Width      | $I_F = 10 \text{ mA/seg}$            |                        |        | 100  | nm                 |
| $C_0$ Capacitance                    | $V_F = 0V, f = 1 \text{ MHz}$        |                        |        | 200  | pF                 |
| $t_r$ Response Time                  |                                      |                        | 500    |      | nsec               |

**INTERNAL CIRCUIT DIAGRAM**

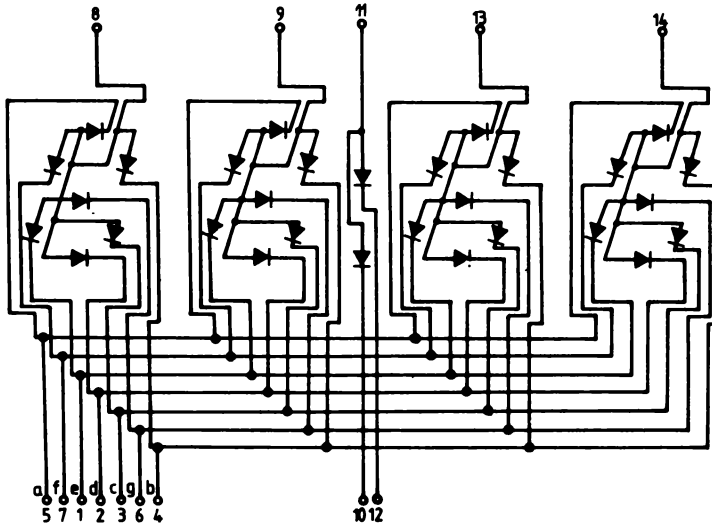

| PIN | FUNCTION  | PIN | FUNCTION                    |
|-----|-----------|-----|-----------------------------|
| 1   | e Cathode | 8   | D <sub>1</sub> Common anode |
| 2   | d Cathode | 9   | D <sub>2</sub> Common anode |
| 3   | c Cathode | 10  | Lower point C               |
| 4   | b Cathode | 11  | Point commonanode           |
| 5   | a Cathode | 12  | Uppon point C               |
| 6   | g Cathode | 13  | D <sub>3</sub> Common anode |
| 7   | f Cathode | 14  | D <sub>4</sub> Common anode |

# 0.3. INCH 4 DIGITS RED OR GREEN LED NUMERIC DISPLAY

## GENERAL DESCRIPTION

The MDE 2583...4R and MDE 2583...4V are common cathode seven segment GaP numeric displays. The large 7.62 (0.3 inch) high characters size generate a bright, continuously uniform seven segment display. They are made on printed circuit boards and plastic encapsulated.

## FEATURES

- High Luminous Intensity
- Wide Viewing Angle
- Uniform Alignment
- IC (TTL) Compatible
- Multiplexed addressable

## APPLICATIONS

To display digital information used in electrical equipments where it is necessary.

## ABSOLUTE MAXIMUM RATINGS

| PARAMETER   | VALUES    | UNIT   |
|---|-----------|--------|
| $I_F$ DC Forward Current  | 20        | mA/seg |
| $I_{FP}$ Pulse (width = 1 msec, duty ratio = 25%) Forward Current | 60        | mA/seg |
| $V_R$ Reverse Voltage   | 3         | V      |
| $P_D$ Power Dissipation   | 300       | mW     |
| $T_A$ Operating Temperature                                       | -40...+85 | °C     |
| $T_{stg}$ Storage Temperature                                     | -40...+85 | °C     |

## PACKAGE DIMENSIONS

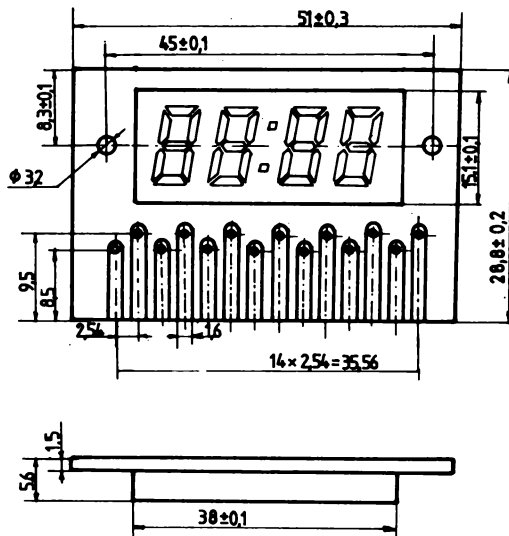

**OPTOELECTRIC CHARACTERISTICS AT  $T_A = 25^\circ C$**

| PARAMETER                            | TEST CONDITIONS                          | DEVICE                 | VALUES |      | UNIT               |
|--------------------------------------|--|------------------------|--------|------|--------------------|
|                                      |  |                        | Min.   | Max. |                    |
| $V_F$ Forward Voltage                | $I_F = 10 \text{ mA/seg}$                |                        | 1.9    | 3    | V                  |
| $V_R$ Reverse Breakdown Voltage      | $I_R = 100 \mu\text{A/seg}$              |                        | 3      |      | V/seg              |
| $I_V$ Luminous Intensity             | $I_F = 10 \text{ mA/seg}$                | MDE 2583R<br>MDE 2583V | 180    |      | $\mu\text{cd/seg}$ |
|                                      |  | MDE 2584R<br>MDE 2584V | 300    |      | $\mu\text{cd/seg}$ |
| $\lambda_p$ Emission Peak Wavelength | $I_F = 10 \text{ mA/seg}$                | MDE 2583R<br>MDE 2584R | 645    | 725  | nm                 |
|                                      |  | MDE 2583V<br>MDE 2584V | 554    | 570  | nm                 |
| $\Delta\lambda$ Line Half Width      | $I_F = 10 \text{ mA/seg}$                |                        |        | 100  | nm                 |
| $C_0$ Capacitance                    | $V_F = 0\text{V}$<br>$f = 1 \text{ MHz}$ |                        |        | 200  | pF                 |
| $t$ Response Time                    |  |                        | 500    |      | nsec               |

**INTERNAL CIRCUIT DIAGRAM**

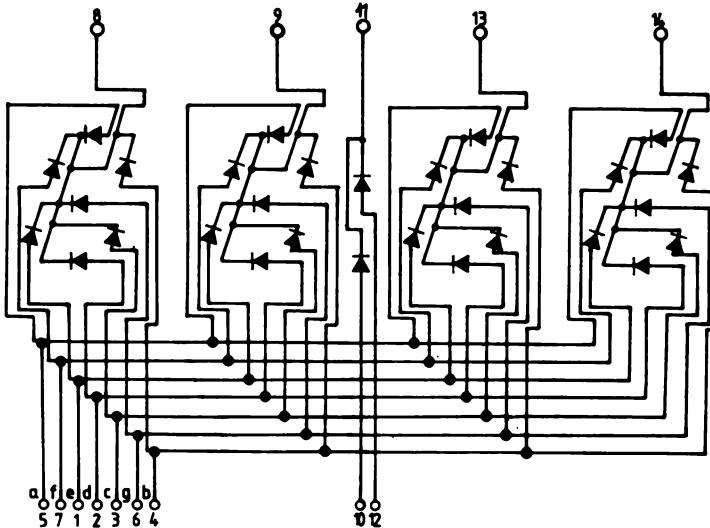

| PIN | FUNCTION | PIN | FUNCTION                      |
|-----|----------|-----|-------------------------------|
| 1   | e Anode  | 8   | D <sub>1</sub> Common cathode |
| 2   | d Anode  | 9   | D <sub>2</sub> Common cathode |
| 3   | c Anode  | 10  | Lower point A                 |
| 4   | b Anode  | 11  | Point commoncathode           |
| 5   | a Anode  | 12  | Uppon point A                 |
| 6   | g Anode  | 13  | D <sub>3</sub> Common cathode |
| 7   | f Anode  | 14  | D <sub>4</sub> Common cathode |

# LIGHT INDICATOR WITH DISCRET LED S (BAR GRAPH DISPLAY)

## GENERAL DESCRIPTION

The MDE 2911...2R (P, G or V) are light indicators with  $GaAs_{1-x}P_x$  ( $x = 0...1$ ) LED s. Discret LED s are made by planar process and epoxy encapsulated. The 10 rectangular LED s are finally encapsulated in a plastic suport.

## FEATURES

- High Luminous Intensity
- Low Power Requirements
- High Reliability and Long Life
- Light Emitting Uniformity

## APPLICATIONS

- Illuminated Legends
- Indicators
- Level Meters
- Audio Devices

## PACKAGE DIMENSIONS

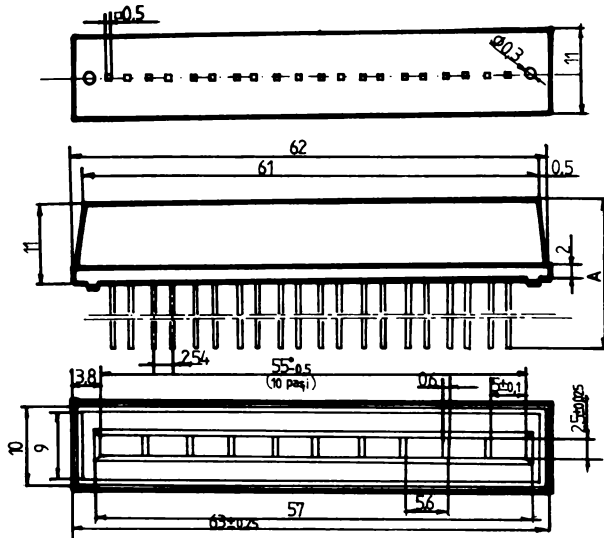

## CONNECTION DIAGRAM

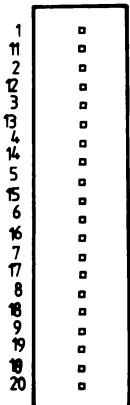

| PIN no | ADRESS  | PIN no | ADRESS    |
|--------|---------|--------|-----------|
| 1      | Anode a | 11     | Cathode a |
| 2      | Anode b | 12     | Cathode b |
| 3      | Anode c | 13     | Cathode c |
| 4      | Anode d | 14     | Cathode d |
| 5      | Anode e | 15     | Cathode e |
| 6      | Anode f | 16     | Cathode f |
| 7      | Anode g | 17     | Cathode g |
| 8      | Anode h | 18     | Cathode h |
| 9      | Anode i | 19     | Cathode i |
| 10     | Anode j | 20     | Cathode j |

## SCHEMATIC DIAGRAM

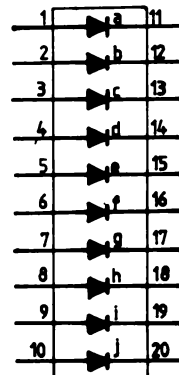

**ABSOLUTE MAXIMUM RATINGS**

| PARAMETER   | VALUES    | UNIT         |
|---|-----------|--------------|
| $I_{Fmax}$ DC Forward Current   | 50        | mA           |
| $I_{Fpeak\ max}$ Peak Forward Current per LED (1 $\mu$ sec. pulse width, 300 pps) | 1         | A            |
| $P_{d\ max}$ DC Power Dissipation per LED   | 150       | mW           |
| $T_A$ Operating Temperature   | 0...+70   | $^{\circ}$ C |
| $T_{stg}$ Storage Temperature   | -40...+85 | $^{\circ}$ C |
| $T_{pad}$ Lead Soldering Temperature  | +260      | $^{\circ}$ C |

**OPTOELECTRONIC CHARACTERISTICS AT  $T_A = 25^{\circ}$ C**

| PARAMETER                            | TEST CONDITIONS                      | DEVICE   | VALUES |      | UNIT |
|--------------------------------------|--------------------------------------|--|--------|------|------|
|                                      |                                      |  | Min.   | Max. |      |
| $I_V$ Luminous Intensity             | $I_F = 20\text{ mA}$                 | MDE 2911R<br>MDE 2911P<br>MDE 2911G<br>MDE 2911V                           | 0.1    | 1    | mcd  |
|                                      |                                      | MDE 2912R<br>MDE 2912P<br>MDE 2912G<br>MDE 2912V                           | 1      |      | mcd  |
| $\lambda_p$ Peak Wavelength          | $I_F = 20\text{ mA}$                 | MDE 2911R<br>MDE 2912R   | 645    | 680  | nm   |
|                                      |                                      | MDE 2911P<br>MDE 2912P   | 625    | 640  | nm   |
|                                      |                                      | MDE 2911G<br>MDE 2912G   | 573    | 590  | nm   |
|                                      |                                      | MDE 2911V<br>MDE 2912V   | 554    | 570  | nm   |
| $V_F$ Forward Voltage/LED            | $I_F = 20\text{ mA}$                 | MDE 2911R<br>MDE 2912R   |        | 2    | V    |
|                                      |                                      | MDE 2911P<br>MDE 2912P<br>MDE 2911G<br>MDE 2912G<br>MDE 2911V<br>MDE 2912V |        | 3    | V    |
| $BV_R$ Reverse Breakdown Voltage/LED | $I_R = 100\ \mu\text{A}$             |  | 3      |      | V    |
| $C_o$ Capacitance/LED                | $V_F = 0\text{ V}, f = 1\text{ MHz}$ | MDE 2911R<br>MDE 2912R   |        | 70   | pF   |
|                                      |                                      | MDE 2911P<br>MDE 2912P<br>MDE 2911G<br>MDE 2912G<br>MDE 2911V<br>MDE 2912V |        | 60   | pF   |

## CROSS REFERENCE GUIDE

| TYPE<br>MICRO-<br>ELECTRONICA | RCA    | NATIONAL<br>SEMICON | SGS-ATES | MOTOROLA | FAIRCHILD | USSR     | CZECH   | GDR   | POLAND | HUNGARY  |
|-------------------------------|--------|---------------------|----------|----------|-----------|----------|---------|-------|--------|----------|
| <b>CMOS 4000 SERIES</b>       |        |                     |          |          |           |          |         |       |        |          |
| MMC 4001                      | CD4001 | CD4001              | HCF4001  | MC14001  | F4001     | K561LE5  | MHB4001 | V4001 |        | 4001BPC  |
| MMC 4002                      | CD4002 | CD4002              | HCF4002  | MC14002  | F4002     | K561LE6  | MHB4002 | —     |        | —        |
| MMC 4011                      | CD4011 | CD4011              | HCF4011  | MC14011  | F4011     | K561LA7  | MHB4011 | V4011 |        | 4011BPC  |
| MMC 4012                      | CD4012 | CD4012              | HCF4012  | MC14012  | F4012     | K561LA8  | MHB4012 | V4012 |        | 4012BPC  |
| MMC 4013                      | CD4013 | CD4013              | HCF4013  | MC14013  | F4013     | K561TM2  | MHB4013 | V4013 |        | 4013BPC  |
| MMC 4015                      | CD4015 | CD4015              | HCF4015  | MC14015  | F4015     | K561IR2  | MHB4015 | V4015 |        | —        |
| MMC 4017                      | CD4017 | CD4017              | HCF4017  | MC14017  | F4017     | K561IE8  | —       | V4017 |        | 4017BPC  |
| MMC 4018                      | CD4018 | CD4018              | HCF4018  | MC14018  | F4018     | —        | —       | —     |        | —        |
| MMC 4019                      | CD4019 | CD4019              | HCF4019  | MC14019  | F4019     | K561LS2  | —       | V4019 |        | —        |
| MMC 4020                      | CD4020 | CD4020              | HCF4020  | MC14020  | F4020     | K561IE16 | MHB4020 | —     |        | 4020BPC  |
| MMC 4023                      | CD4023 | CD4023              | HCF4023  | MC14023  | F4023     | K561LA9  | —       | V4023 |        | 4023BPC  |
| MMC 4024                      | CD4024 | CD4024              | HCF4024  | MC14024  | F4024     | K176IE1  | MHB4024 | —     |        | —        |
| MMC 4025                      | CD4025 | CD4025              | HCF4025  | MC14025  | F4025     | K561LE10 | —       | —     |        | —        |
| MMC 4027                      | CD4027 | CD4027              | HCF4027  | MC14027  | F4027     | K561TV1  | —       | V4027 |        | 4027BPC  |
| MMC 4028                      | CD4028 | CD4028              | HCF4028  | MC14028  | F4028     | K561ID1  | —       | V4028 |        | 4028BPC  |
| MMC 4029                      | CD4029 | CD4029              | HCF4029  | MC14029  | F4029     | —        | MHB4029 | V4029 |        | 4029BPC  |
| MMC 4030                      | CD4030 | CD4030              | HCF4030  | MC14507  | F4030     | K561LP2  | MHB4030 | V4030 |        | 4030BPC  |
| MMC 4031                      | CD4031 | CD4031              | HCF4031  | —        | F4031     | K176IR4  | —       | —     |        | —        |
| MMC 4035                      | CD4035 | CD4035              | HCF4035  | MC14035  | F4035     | K561IR9  | —       | V4035 |        | —        |
| MMC 4041                      | CD4041 | CD4041              | HCF4041  | MC14041  | F4041     | —        | —       | —     |        | —        |
| MMC 4042                      | CD4042 | CD4042              | HCF4042  | MC14042  | F4042     | K561TM3  | —       | V4042 |        | 4042BPC  |
| MMC 4043                      | CD4043 | CD4043              | HCF4043  | MC14043  | F4043     | K561LTR2 | —       | —     |        | —        |
| MMC 4044                      | CD4044 | CD4044              | HCF4044  | MC14044  | F4044     | —        | —       | V4044 |        | 4044BPC  |
| MMC 4047                      | CD4047 | CD4047              | HCF4047  | —        | F4047     | —        | —       | —     |        | —        |
| MMC 4049                      | CD4049 | CD4049              | HCF4049  | MC14049  | F4049     | K561LN2  | —       | —     |        | 4049UBPC |
| MMC 4050                      | CD4050 | CD4050              | HCF4050  | MC14050  | F4050     | K561PU4  | MHB4050 | V4050 |        | 4050BPC  |
| MMC 4051                      | CD4051 | CD4051              | HCF4051  | MC14051  | F4051     | K561KP2  | MHB4051 | —     |        | —        |
| MMC 4052                      | CD4052 | CD4052              | HCF4052  | MC14052  | F4052     | K561KPI  | MHB4052 | —     |        | —        |
| MMC 4053                      | CD4053 | CD4053              | HCF4053  | MC14053  | F4053     | —        | MHB4053 | —     |        | —        |
| MMC 4054                      | CD4054 | CD4054              | HCF4054  | MC14054  | F4054     | —        | —       | —     |        | —        |
| MMC 4060                      | CD4060 | CD4060              | HCF4060  | MC14060  | F4060     | —        | —       | —     |        | 4060BPC  |
| MMC 4066                      | CD4066 | CD4066              | HCF4066  | MC14066  | F4066     | K561KT3  | MHB4066 | —     |        | 4066BPC  |
| MMC 4067                      | CD4067 | —                   | HCF4067  | —        | F4067     | —        | —       | —     |        | —        |
| MMC 4069                      | CD4069 | CD4069              | HCF4069  | MC14069  | F4069     | —        | —       | —     |        | 4069UBPC |
| MMC 4071                      | CD4071 | CD4071              | HCF4071  | MC14071  | F4071     | —        | —       | —     |        | 4071BPC  |
| MMC 4072                      | CD4072 | CD4072              | HCF4072  | MC14072  | F4072     | —        | —       | —     |        | —        |
| MMC 4073                      | CD4073 | CD4073              | HCF4073  | MC14073  | F4073     | —        | —       | —     |        | 4073BPC  |
| MMC 4081                      | CD4081 | CD4081              | HCF4081  | MC14081  | F4081     | —        | MHB4081 | —     |        | 4081BPC  |
| MMC 4093                      | CD4093 | CD4093              | HCF4093  | MC14093  | F4093     | —        | —       | V4093 |        | 4093BPC  |

| TYPE MICRO-ELECTRONICA | RCA     | NATIONAL SEMICOND. | SGS-ATES | MOTOROLA | FAIRCHILD | USSR     | CSECH   | GDR | POLAND HUNGARY |
|------------------------|---------|--------------------|----------|----------|-----------|----------|---------|-----|----------------|
| MMC 4097               | CD4097  |                    | HCF4097  |          |           |          |         |     |                |
| MMC 4098               | CD4098  | CD4098             | HCF4098  | MC14598  | F4098     |          |         |     | 4098BPC        |
| MMC 40104              |         |                    | HCF40104 |          |           |          |         |     |                |
| MMC 40107              | CD40107 |                    | HCF40107 |          |           |          |         |     |                |
| MMC 40181              | CD40181 | CD40181            | HCF40181 | MC14581  | F40181    |          |         |     |                |
| MMC 40192              | CD40192 | CD40192            | HCF40192 | MC140192 | F40192    |          |         |     |                |
| MMC 4510               | CD4510  | CD4510             | HCF4510  | MC14510  | F4510     |          |         |     | 4510BPC        |
| MMC 4511               | CD4511  | CD4511             | HCF4511  | MC14511  | F4511     |          | MHB4511 |     | 4511BPC        |
| MMC 4516               | CD4516  | CD4516             | HCF4516  | MC14516  | F4516     |          |         |     | 4516BPC        |
| MMC 4518               | CD4518  | CD4518             | HCF4518  | MC14518  | F4518     |          | MHB4518 |     | 4518BPC        |
| MMC 4520               | CD4520  | CD4520             | HCF4520  | MC14520  | F4520     | K5611EIO |         |     |                |
| MMC 4543               | CD4543  | CD4543             | HCF4543  | MC14543  | F4543     |          | MHB4543 |     |                |

### RAM MEMORIES

|          |        |       |  |         |  |         |         |      |                |
|----------|--------|-------|--|---------|--|---------|---------|------|----------------|
| MMN 2102 | MM2102 | M2102 |  |         |  | K565RU2 | MHB2102 | U202 | MCY7102 2102PC |
| MMN 2114 | MM2114 | M2102 |  | MCM2114 |  |         | MHB2114 |      | MCY7114        |
| MMN 4027 | MM5280 | M4027 |  | MCM4027 |  |         |         |      |                |
| MMN 4116 | MM5290 | M4116 |  | MCM4116 |  | K565RU3 | MHB4116 | U256 | 4116PC         |

### MMN 8080 MICROPROCESSOR FAMILY

| TYPE MICRO-ELECTRONICA | INTEL | NATIONAL SEMICOND. | TEXAS INSTRUMENTS | USSR       | POLAND    |
|------------------------|-------|--------------------|-------------------|------------|-----------|
| MMN 8080               | 8080  | INS 8080           | TMS 8080          | KR580IK80A | MCY7880   |
| MMN 8251               | 8251  | INS 8251           | TMS 8251          | KR580IK51  | MCY7851   |
| MMN 8255               | 8255  | INS 8255           | TMS 8255          | KR580IK55  | MCY7855   |
| MMN 8257               | 8257  | INS 8257           | TMS 8257          |            |           |
| MMN 8205               | 8205  | INS 8205           | TMS 8205          | KR580IK57  |           |
| MMN 8214               | 8214  | INS 8214           | TMS 8214          |            | UCY74S405 |
| MMN 8216               | 8216  | INS 8216           | TMS 8216          |            | UCY74S414 |
| MMN 8224               | 8224  | INS 8224           | TMS 8224          |            | UCY74S416 |
| MMN 8226               | 8226  | INS 8226           | TMS 8226          |            | UCY74S424 |
| MMN 8228               | 8228  | INS 8228           | TMS 8228          |            | UCY74S426 |
| MMN 8238               | 8238  | INS 8238           | TMS 8238          |            | UCY74S428 |

### MMN 80 MICROPROCESSOR FAMILY

| TYPE MICROELECTRONICA | SGS-ATES   | ZILOG      |
|-----------------------|------------|------------|
| MMN 80 CPU            | Z 8400     | Z 80 — CPU |
| MMN 80 SIO            | Z 8440/1/2 | Z 80 — SIO |
| MMN 80 CTC            | Z 8430     | Z 80 — CTC |
| MMN 80 PIO            | Z 8420     | Z 80 — PIO |
| MMN 80 DMA            | Z 8410     | Z 80 — DMA |

## ANALOG SWITCHES

| TYP MICROELECTRONICA | SILICONIX | INTERSIL | NATIONAL SEMICONDUCTORS |
|----------------------|-----------|----------|-------------------------|
| MMP 115              | G 115     | G 115    | MM 5504*                |
| MMP 116              | G 116     | G 116    | —                       |
| MMP 117              | G 117     | G 117    | —                       |
| MMP 119              | G 119     | G 119    | —                       |
| MMP 122              | G 122     | G 122    | MM 550*                 |
| MMP 124              | G 124     | MM 551*  | MM 551*                 |

## SHIFT REGISTERS

| MICROELECTRONICA | PHILIPS MULLARD SIEMENS |
|------------------|-------------------------|
| MMP 156          | FDN 156                 |

## PMOS

| MICROELECTRONICA | SIEMENS | GDR   | MOSTEK             |
|------------------|---------|-------|--------------------|
| MMP 131          | SAJ 131 | —     | —                  |
| MMP 190          | \$190   | —     | —                  |
| MMP 710          | —       | U 710 | —                  |
| MMP 711          | —       | U 711 | —                  |
| MMP 5002/5/7     | —       | —     | —                  |
| MMP 5009         | —       | —     | MK 5002<br>MK 5009 |

## SPECIAL CMOS

| MICROELECTRONICA | ITT     | SGS — ATEs |
|------------------|---------|------------|
| MMC 300          | SAJ 300 | M 730      |
| MMC 760          | —       | M 760      |

\* functional equivalent



## **ERRATUM**

Page 285:

To the table DECODER INPUT DATA read INPUT DATA not OUTPUT DATA

Page 306:

The characteristics of MDE 1541 3 R P G V same to MDE 1101 3R P G

**All connection diagrams are top view.**



Tiparul executat sub comanda nr. 40441 la  
Combinatul Poligrafic „Casa Științei”,  
Str. Piața Științei Nr. 1 — București  
Republica Socialistă România



